

# SMITH MINIPLANE

**SIG**  
Craftsman's Kit  
SIGRC38



## Building and Flying Instructions

**Sig Mfg. Co., Inc....401-7 South Front Street...Montezuma, Iowa 50171**

Historically, the Smith Miniplane is one of the designs responsible for the current popularity of small homebuilt biplanes. In 1957, before the E.A.A. BIPLANE, the SKYBOLT, the STARDUSTER, or the ACRO SPORT, homebuilding consisted mainly of the FLY BABY design and a few PITTS SPECIALS. Out of a garage in Fullerton, California came a small biplane that was new, simple and cute. Designed and built by Frank Smith, and designated DSA-1 (DARNED SMALL AIRPLANE), it was an outstanding example of engineering with the amateur homebuilder and pilot in mind. It could be constructed with tools easily within reach of the average craftsman, and its nimble, yet stable, flight performance covered the capabilities of most week end pilots. Powered by a 100 hp Lycoming. Frank's prototype proved to be fully aerobatic, cruised at 120 mph, and climbed at almost 2,500 ft. per minute. The top wing spanned 17 ft., the fuselage was 15 ft. long, and the empty weight was just over 600 pounds. Work was started on a second Miniplane and on a detailed construction plan set for sale to the Miniplane's new enthusiasts. Frank Smith died before either were finished, but his co-workers completed the plans which resulted in dozens of examples being built.

In 1974, Glen Sigafoose, President of Sig Mfg. Co., acquired a completed Smith Miniplane that had been constructed in 1967. Glen's Smith sports a dazzling red, white, and black paint scheme and was the inspiration for this mini version of the Miniplane.

### About The Model

This Miniplane model was designed with easy, yet scalelike construction and good flight characteristics in mind. The exact scale outlines have been modified where it was thought necessary to obtain optimum areas, moments, and cross-sections for stable sport flying and aerobatics. Yet its strong resemblance to the full size Miniplane makes it a serious contender in AMA Sport Scale.

You should realize that it is common among homebuilt versions of the same aircraft for some component shapes (tail surface outlines, wing tips, etc.) to vary from plane to plane depending on how the individual builder happened to bend the tubing. Also, different engine installations often produce distinct differences in the shape of the cowling and related scoops. The model was designed from photos and measurements of Glen's actual aircraft. Towards the end of these instructions is a 3-View drawing of Glen's full size Miniplane for use in Sport Scale judging.



## Before Beginning Construction



This build guide lists step-by-step assembly instructions, keyed by paragraph number to the isometric drawings and the photos. This does not mean that the sequence must be followed exactly, step-by-step. You may wish to work on several parts at the same time to speed construction. It may be desirable, for example, to start building the wing or tail, while the preliminary parts of the fuselage are drying. It is suggested that you read the instruction book and study the plans carefully before beginning to build. That will help make it clear where construction out of the descriptive sequence can be done. Any reference to right or left refers to your right or left as if seated in the cockpit.

A piece of Celotex-type wallboard makes a handy building board, into which pins can easily be pushed. Lay the building board on a table with a flat and untwisted top. Pins can be pushed through all pieces of balsa in the kit without any lasting damage. The holes on the outside will fill up during sanding and doping. Don't be afraid to use plenty of pins, particularly when gluing planking on the top curve of the wing or the round top of the fuselage front.

Wax paper should be used to protect the plan during building when the glue used is epoxy or an aliphatic resin glue such as Sig-Bond. If a model cement like Sig-Ment is preferred, use plastic wrap to protect the drawing. This type of glue can dissolve the wax out of wax paper which will inhibit drying.

Be careful where you use a ball point pen for making marks. If not sanded off, these marks will bleed through many coats of dope and show on the finished model.

Cut all long pieces of balsa first, followed by medium lengths, before cutting up any full length strips into short pieces. Leave the die-cut parts in the sheets until needed in construction. Remove pieces from the sheets carefully. If difficulty is encountered, do not force the part from the sheet. Use a modeling knife to cut it free.

A jig saw is best for cutting out the printed balsa parts. Cut just outside the lines, leaving all of the line on the part. When fitting into place in the structure, use a sanding block to bring the edges to an exact fit. If an X-Acto knife is used don't cut too close to the lines but leave enough margin to true up and finish the edge with a sanding block.





Read these instructions completely and study the full size plan before beginning to work.

## MAIN CONSTRUCTION

Any reference to right or left refers to right or left as if seated in the cockpit.

### 1. Fuselage Main Frame

- Cut the nose doublers, wing saddles, and the tail posts from the 1/4" printed balsa sheets.
- Protect the fuselage main frame drawing on plate 1 with wax paper or plastic wrap.
- Pin the long, top 1/4" sq. balsa piece to the plan.
- Glue and pin in place the wing saddle, the 1/4" sq. upright (between the wing saddle and the nose doubler), the nose doubler and finally the tail post.
- Cut and glue the remaining 1/4" sq. pieces in place.

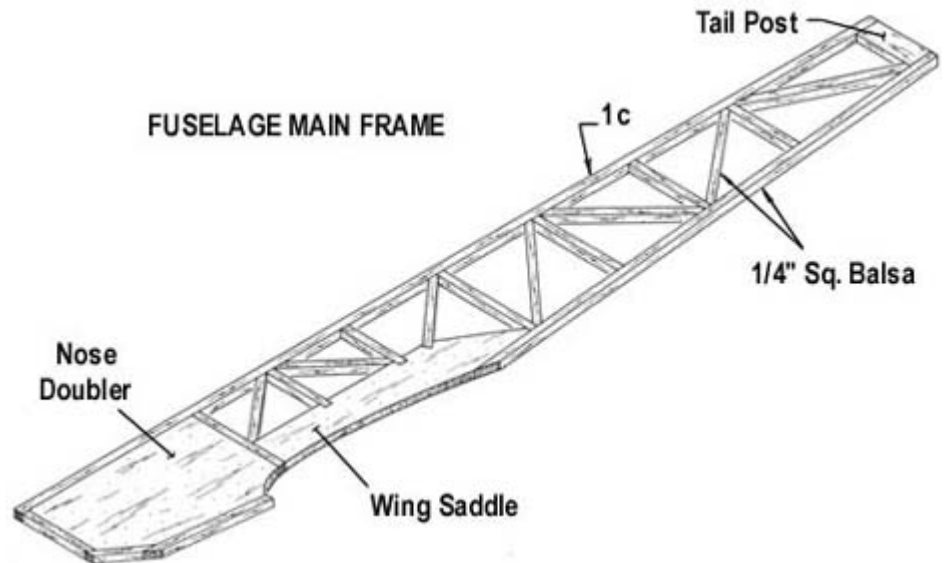

- When dry, remove the pins and build a second frame side directly on top of the first. Use wax paper or plastic wrap to keep the two sides from sticking together.
- When dry, pin both main frame sides directly together and carefully even up the edges with the sanding block.

### 2. Firewall

- The firewall is made by gluing the two die-cut 1/8" plywood F1 parts together to form a 1/4" thick piece. Use epoxy glue and weight down flat until the glue sets up.

- b. The recommended engine installation, using a side mounted engine, is shown on the plan. The original models used no engine offset to the right or down and this gave good results. It is easiest to install the engine mounts before the firewall is attached to the fuselage. Mark the vertical and horizontal center lines on the firewall, using the drawing on the plan as a reference. Determine the spacing required between the engine mounts for your engine. Mark the appropriate mount locations and mounting hole spots on the firewall.
- c. Drill the engine mount holes in the firewall. Epoxy 6-32 blind nuts to the back of the firewall to retain the mounts. The holes in the firewall must be large enough to allow the blind nuts to pull into the firewall when the mounting bolts are tightened.
- d. The engine should be positioned on the aluminum mounts so that the spinner backplate is about 1/16" to 3/32" ahead of the cowling. With the mounts bolted in place on the firewall, determine the proper location of the engine on the mounts and mark the mounting holes. Drill the holes with a #36 drill, and tap for 6-32 mounting bolts.

**SPECIAL NOTE:**

The backplate on Goldberg spinners has a recessed back, so the engine must be mounted about 1/8" farther ahead than when using other brands of spinners. This is not a problem, but it is best to have the spinner on hand - whatever the brand - when installing the cowl, to be sure of good alignment.

### 3. Joining The Fuselage Sides

- a. Bevel the rear ends of the fuselage sides on the inside as shown on the full size plan.
- b. Cover the top view of the fuselage plan with wax paper or plastic wrap. The sides are joined over the top view upside down - flat top of the sides against the building board. Start by pinning down the sides at the front (about the first 9") and joining along the top with several temporary 1/4" sq. cross-pieces. Join at the bottom by gluing the two grooved hardwood landing gear blocks in place. Check carefully that the grooves in the blocks are 2-1/4" apart as shown in the side view.

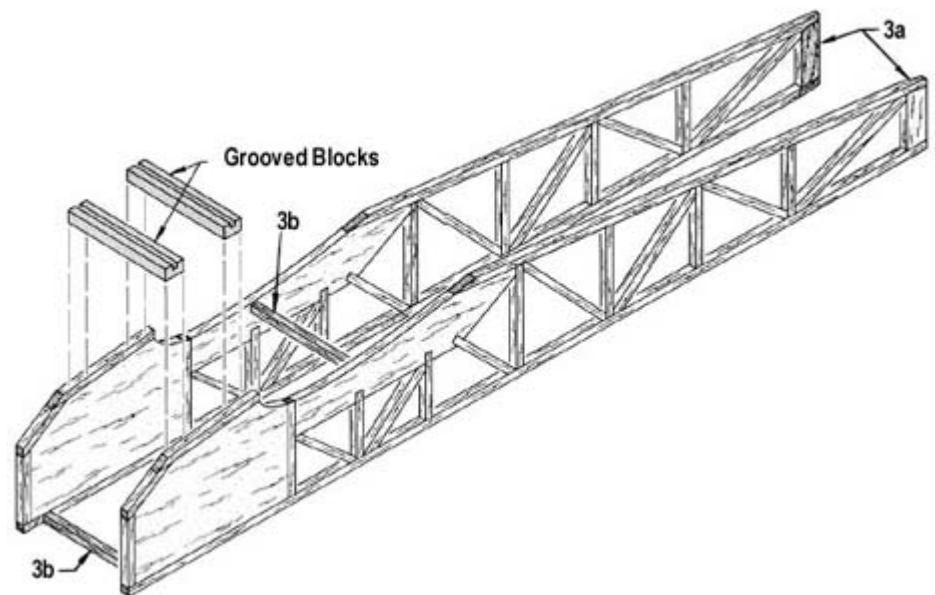

- c. Add plywood piece F11.
- d. After the front joints have dried, continue joining the sides toward the rear with 1/4" sq. cross-pieces.
- e. When dry, remove the joined sides from the board and epoxy the firewall to the front. Note that the firewall sticks up above the main frame sides. Position accurately by marking the thrust line on the fuselage sides (the thrust line is 1/2" from the top of the main frame) and aligning the mark with the thrust line previously drawn on the firewall. When dry, the temporary 1/4" sq. balsa cross-pieces along the top can be removed.
- f. Should the 1/4"x1/2" balsa provided for assembly under plywood platform F10 be a little bowed or not perfectly flat on one side, correct it with a sanding block. Carefully draw a line 1/4" from the top of the trued side.

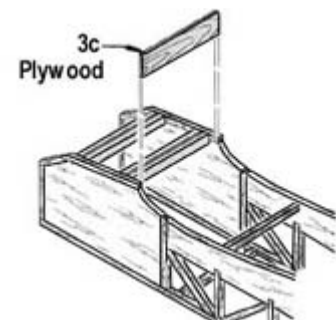

- g. Glue the 1/4"x1/2" pieces inside the fuselage frame with the trued side up. Position the line drawn on them exactly on the top of the fuselage sides - with 1/4" protruding above the sides. The top of the pieces must be parallel to the top of the sides so that the plywood platform F10 will also be parallel and thus set the wing incidence at 0 degrees.
- h. Epoxy the plywood platform F10 squarely in place.
- i. Carefully draw lines on F10 marking the exact center lines of the 1/8" LD. brass tubing cabane strut mounts. J-bolts are used to anchor the mounts. Put a piece of 1/8" dia. wire into the tubing when tightening down the J-bolts to prevent the tubing from being distorted. Do not overtighten. Check carefully to see that the distance between both mounts is exactly the same on both sides - 4-5/16" center to center. Check also that the tubing is parallel to the firewall and at right angles to the fuselage sides. When satisfied with the alignment, coat the tubing and J-bolts (top and bottom) with epoxy glue so that they will not vibrate loose later.

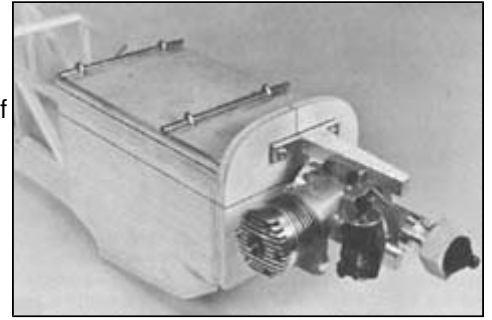

#### 4. Completing The Fuselage

- a. Glue the rear formers F5A, F5B, F6, F7, F8 and F9 to the fuselage at the locations shown on the plan.
- b. Glue the seven 1/8"x1/4" top stringers on formers F5B thru F9. Check the cross-section drawings on the plan for the correct positioning.

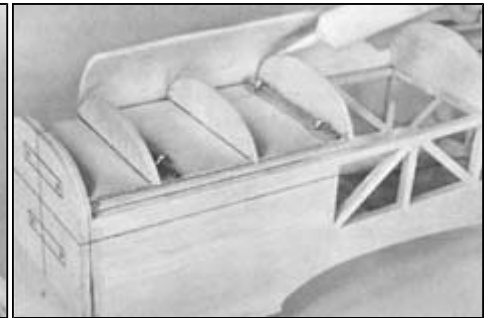
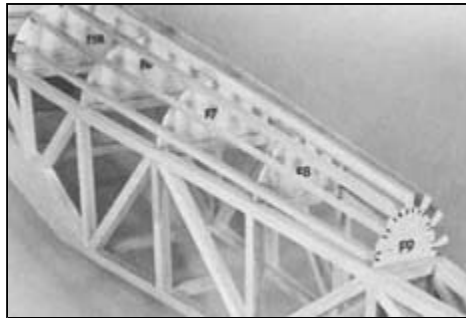

- c. Glue front formers F2, F3 and F4 in place.
- d. Attach the 1/8" sheet front fuselage planking in sections as follows:

##### Over The Formers:

Use two 4" wide sheets to allow planking over the left and right sides of the formers separately with with a seam at the top. Note also that there are two F2 formers to allow the areas fore and aft to be sheeted with separate pieces, duplicating the profile of the full size Miniplane.

Start on one side by gluing and pinning a sheet to the top 1/4" sq. of the main frame. Glue only the area of formers F2 thru F5A. Trim the sheet roughly to shape after trial bending over the formers. Wet the outside surface of the sheet if necessary to aid in bending. Trim away most of the sheet in the cockpit area, but leave enough for a final trimming and shaping later. Apply glue to the formers and start pinning the sheet securely to the formers working along the bottom first, then upwards. Trim the sheet straight along the top, and along the front (it should cover just the second F2). Apply sheet to the other side, joining with the first sheet at the top of the formers. Plank across the firewall and the first F2 former in the same manner.



##### Nose Sides And Bottom:

Use 4" wide sheets to cover the sides. Spread glue over the nose doublers and butt the sheet against the previously attached top planking. Push firmly in place, forcing out any air pockets to get a strong wood to wood lamination. Use plenty of pins to hold the sheet securely while drying. Wipe off any excess glue and trim the edges straight.

Fill in the openings in the bottom nose sections between the firewall, the landing gear blocks, and the F10 plywood with 1/8" sheet balsa. Run the grain of the sheets crosswise.

- e. Glue to the fuselage all 1/8" sq. side stringers, and the 1/8"x1/4" bottom stringers and tail filler pieces. Taper these stringers in the last 1-1/2" of their length to the thickness of the tail post at the rudder hinge line. (SEE TOP VIEW ON PLAN.)

- f. Fill in between the lower stringers, over the wing saddle with 1/8" sheet balsa.
- g. Notch the fuselage and epoxy the plywood tail wheel bracket mount F12 in place.
- h. Inset 1/8"x3/4"x2-3/8" plywood cowl mount inserts into the fuselage side at location shown on the plan.
- i. Shape the fuselage with a knife and sanding block to the cross-sections shown on the plan. You will need the cowl to get the shape of the nose area just right for a good fit.

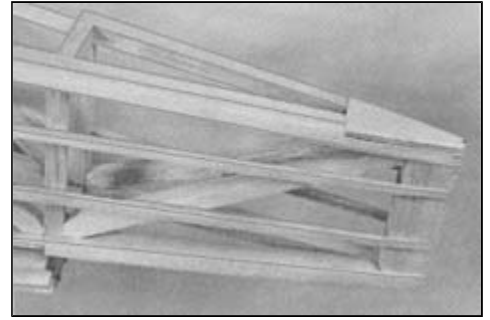

## 5. Cowling

The cowling should be assembled and fitted to the fuselage before the fuselage is covered and painted. Careful shaping of the nose is necessary to achieve a good fit. Butyrate dope thinner, MEK or cyanoacrylate adhesives can be used to assemble the cowl.

Note: Read about an Optional Cowl Reinforcement Method below before starting.

- a. Cut away the excess plastic around the lower air exit flange at the rear of both cowl halves.
- b. Tape the cowling halves together and try a preliminary fit of the- match to the fuselage. If the cowl fits the fuselage too loosely, remove a little width by sanding down the seam between the two halves. Sand very lightly.
- c. Untape the cowl when the fit is satisfactory. Hold the plastic joiner strip in place on the inside of one half. Leave half of the joiner strip extending over the edge so as to lap onto the other cowl half when it is attached. Using a small, pointed brush, flow a few drops of thinner under the edge of the strip. It will spread along the seam by capillary action. Don't let the thinner get under your finger, it will leave a finger print.
- d. Hold the cowl halves tightly together. Use strips of masking tape to hold the opposite side (top or bottom) from which you will be gluing first. Flow thinner into the seam from the inside. Squeeze and hold together any parts of the seam not closed. Allow to dry. Remove the masking tape and join the halves on the other side. Allow to dry thoroughly.

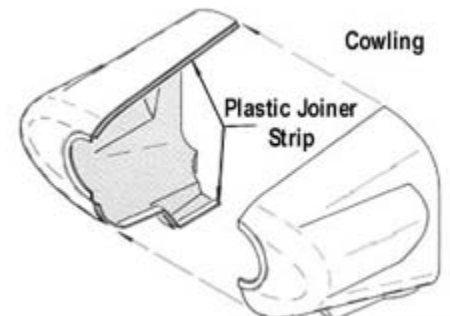

Read section 16, "Sanding And Painting Plastic Parts", before sanding the cowl surface.

- e. Even up the back edges of the cowl with a sanding block.
- f. Scrape and sand the seam to take out any rough spots or flaws. Do not use coarse sandpaper that will cut deep scratches in the plastic. The deep scratches may later open up wider when dope is applied. Use medium paper and finish carefully with fine paper, sanding down enough to have a smooth, scratch-free surface. Low spots in the seam can be filled with Sig Epoxolite putty. Don't put on too much Epoxolite and expect to sand away the excess later. Epoxolite dries very hard and must be worked into the final desired shape before it hardens. Epoxolite can easily be shaped with your finger and/or a single edge razor blade. Dip them in water occasionally to keep the Epoxolite from sticking to them.

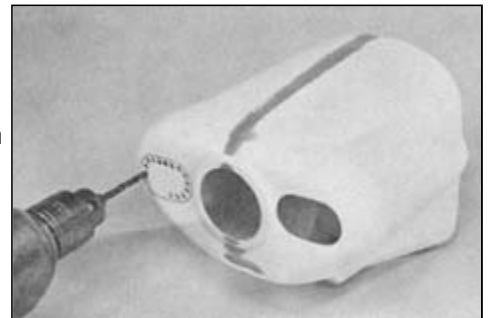

- g. Cut out the 3 air intake openings in the front of the cowl using the patterns on the fuselage plan front view for the exact size and location. Mark the openings on the front of the cowl. Drill a series of holes about 1/8" in diameter around the inside of the marks - have the holes almost touching each other. Cut through the bits of plastic between each of the drilled holes with a knife and break out the part to be removed. Once the preliminary openings are made, the edges can be trimmed to exact shape with an X-Acto knife.
- h. Cut out the backs of the side scoops to provide more exit space for the engine cooling air. The most important factor in cooling a fully cowed engine is to keep a constant stream of fresh, cool air moving thru the cowling by having more exit area than incoming area. Inadequate exit space can cause the heated air to be trapped in the cowl, which causes the engine to overheat.

- i. Mount the engine on the fuselage. Slip the cowl in place and attach the spinner to the engine. Tape and hold the cowl in correct alignment with the spinner and the fuselage. Leave about 1/16" between the back of the spinner backplate and the front of the cowl. Drill a pilot hole through the cowl and into the plywood insert in the fuselage.

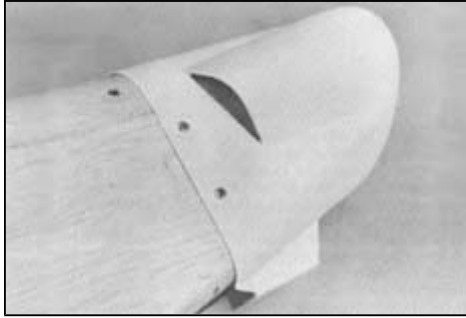

Open up the cowl holes so they are large enough to pass the mounting screws.

- j. Make small openings where necessary to allow access to the needle valve and glow plug.

NOTE: Do not try to cover any of the plastic parts with monokote or other iron-on types of covering material. The heat can damage the plastic parts.

The most common cause of plastic cowls cracking is distortion of the plastic from improper installation of the plywood mounting inserts and retaining screws. If the plastic is fully supported by the plywood underneath, no strain will occur when the screws are tightened down.

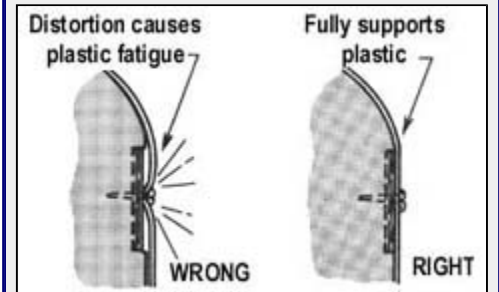

### Optional Cowl Reinforcement Method (Materials not supplied)

The strength of the cowling may be increased by lining the inside with fiberglass cloth and resin. This leaves the outside surface smooth and easy to paint. The photos show a Sig Kommander cowl, but the same method applies to the Miniplane cowl. Completely assemble the two-piece cowl before lining the inside with glass cloth.

IMPORTANT: Since this procedure will make the inside dimensions of the cowl slightly smaller, it may be necessary to sand down the firewall and/or the nose of the model for best fit. Look ahead to this probability during the building of the model. You may want to sand down the sides and top of the plywood firewall about 1/32" before it is assembled into the fuselage.

1. Sand the entire inner surface of the cowl with 80 grit garnet sandpaper or similar coarse grained paper. Remove all of the gloss from the plastic with the sandpaper or the resin will not adhere properly. Don't worry about scratches from the paper, a rough surface will help the cloth and resin stick down. Do not sand the outside of the cowl with this coarse paper. Use only 220 and 360 Tri-M-Ite paper or equivalent and avoid scratching.
2. Cut a piece of Sig Regular Weight Glass Cloth that will fit into the cowl and cover the entire inside surface. The cloth is stretchy and can be formed to the contours. If you have had no experience in handling glass cloth, it may be easier to use two pieces of cloth, covering half of the inside at a time.
3. Mix only about 1 to 1-1/2 oz. of Sig Glass Resin at a time. Add 4 or 5 extra drops of hardener over the amount called for in the directions on the can. The cowl area to be coated is small and will not take much time so the extra hardener will speed up the set up time. Paint the cloth onto the inside surface of the cowl with the resin mix. Pat out any wrinkles in the cloth while painting. A few cuts into the cloth around the trim area helps to make the cloth easier to handle. Apply resin to about 1/8" of the waste cloth sticking out from the cowl all around the edges. This resined area makes it easier to trim off the excess without the cloth threads unraveling and makes for a smoother edge.
4. Do not flex or handle the cowl excessively while the resin is setting up. This may damage adhesion of the resin to the cowl. When the resin has set up hard, the waste glass cloth can be trimmed from the edges with a single edge razor blade or a modeling knife. If there are any uneven spots or ridges near the back of the cowl where it must slip over the fuselage, sand them down smooth.
5. If there are any uneven spots or ridges in the first 1/4" of cloth inside the back edge of the cowl, sand them down smooth. Plastic screw hole reinforcement strips will not be necessary if this glass cloth reinforcing method is used.

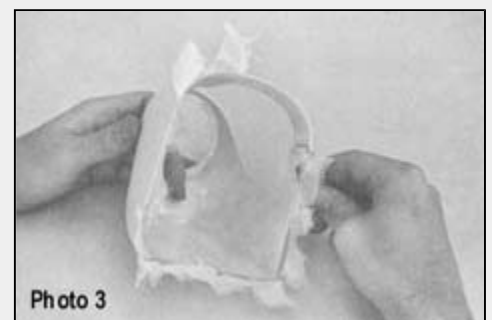
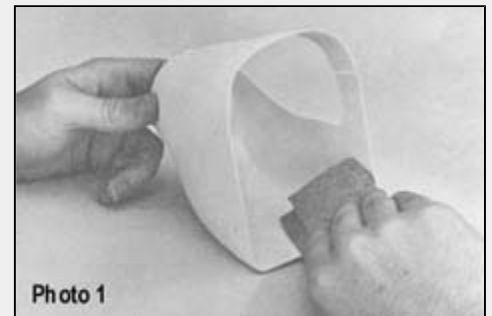

## 6. Landing Gear

Assembly of the landing gear requires the constructed fuselage.

- a. Place the 1/8" landing gear wires into the grooved hardwood blocks. Screw the retaining straps in place.
- b. Bind the legs of the 1/8" rear brace wire to the main landing gear legs with copper wire. Solder securely. Use sufficient soldering paste to flow the solder completely around and through the bindings. Protect the fuselage during the soldering operations with a cloth so that dripping solder or paste will not fall on the wood.
- c. The wheel pant halves are joined in the same manner as the cowl except that the joiner strips are not necessary. Cut out the wheel openings before joining the halves. Squeeze the parts together snugly while flowing thinner into the seam.

- d. The prototype models used Fox 1/8" Flanged Wheel Collars (#90343) to secure the wheel pants to the landing gear axles. Cut a small slot in the inside half of each pant, wide and long enough to allow it to slip down into position over the axle. Assemble the wheels, collars, and pants onto the landing gear. The pants should be level when the fuselage is level.

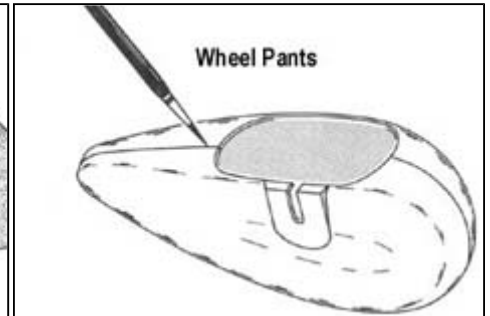
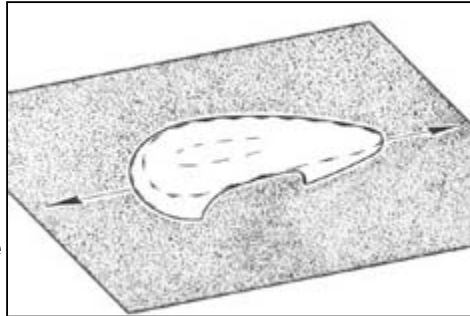

When they are positioned correctly, tighten the set screws in the collars against the axles. Carefully remove the wheel pants and wheels without disturbing the position of the flanged collars. Solder the flanged collars to the axles.

(NOTE: We have found that the set screws alone cannot hold the pant securely in position after repeated takeoffs and landings. A little solder has eliminated the problem on our test models.)

- e. Remove the landing gear assembly and clean it thoroughly with sandpaper and dope thinner.
- f. Epoxy the 1/8" sq. and 1/8"x1/4" balsa fairing pieces to the wires. Carve and sand to streamline shape. Fill in the gaps over the 1/8" wire with Epoxolite Putty.

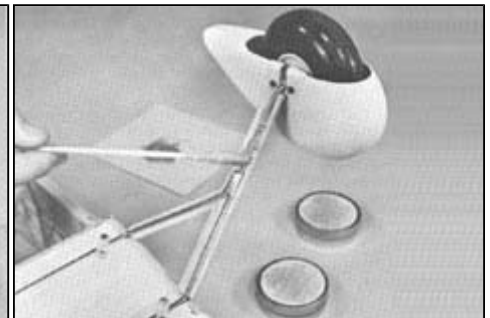
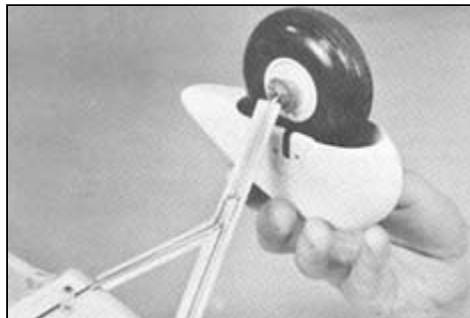
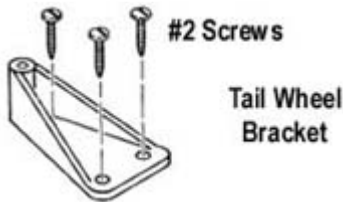

- g. The tail wheel assembly should be installed after the fin and rudder have been attached to the fuselage, but before they are color painted. When that point is reached later on, come back to this section and proceed as follows: Insert the tailwheel wire into the nylon bracket. Bend the top section of the wire parallel with the bottom of the rudder. Inset the wire into the bottom of the rudder and screw the nylon bracket in place on F12. Reinforce the bottom of the rudder with glass cloth and epoxy glue. The tail wheel (not included) can be retained on the axle wire with 1/16" wheel collars (not included) or by soldering a flat metal washer onto the axle on each side of the wheel.

## 7. Stabilizer And Elevators

Cover the plan with wax paper or plastic wrap. Pin the parts to the plan, gluing them to each other in the following order;

- a. 1/4"x1/2" balsa stabilizer trailing edge.
- b. The 1/4"x1/2" elevator leading edge and the 1/4" diameter dowel elevator joiner. Be careful not to glue these parts to the stabilizer T.



- c. All parts 51, 52, & 53 from the printed sheet.
- d. Add remaining 1/4"x1/2" balsa pieces - the stab. leading edges, the elevator trailing edges and the sides.
- e. The 1/8"x1/4" balsa ribs.
- f. The 1/4" gussets S4 in the elevators.
- g. When dry, sand the outside edges to a rounded shape.

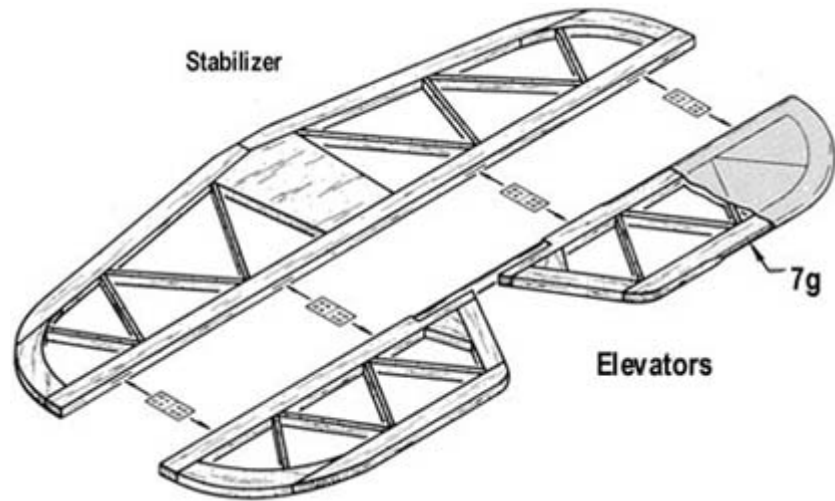

## 8. Fin And Rudder

The fin and rudder are assembled over the plan in the same manner as the stab and elevator.

- a. Pin the 1/4"x1/2" fin T.E. and Rudder L.E. to the plan. Do not glue to each other.
- b. R1 and R2 printed pieces.
- c. 1/4"x1/2" fin bottom rib and rudder bottom edge.
- d. R3 and R4 printed pieces.
- e. 1/4"x1/2" fin leading edge and rudder trailing edge.
- f. Cut to length and glue in place the 1/8"x1/4" balsa ribs.
- g. When dry, sand the outside edges round.

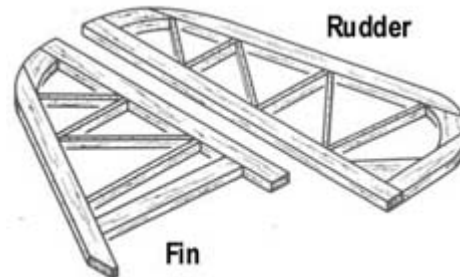

### NOTE:

The stabilizer, elevators, fin and rudder are the easiest to cover before they are hinged and attached to the fuselage. However, before covering, you should test assemble the tail surfaces on the hinges, without glue, to insure that a good edge and end match has been obtained in the sanding operation. Then refer to the Covering & Painting section and prepare the tail surfaces thru the point of covering and applying at least 2 coats of clear dope, before gluing in the hinges permanently



An 108 HP Lycoming coupled with light weight produces a snappy aerobic performer

## 9. Top Wing Assembly

- a. Pin the 3/16"x5/16" bottom spars and the 3/16"x3/8" rear spars to the plan. Use epoxy to join the spars in the center to the wing.
- b. Glue a W3 half rib to the right side of both ribs marked W1a. Glue a W3 half rib to the left side of both ribs marked W1 b.

- c. Glue the W1a and W1b rib assemblies to the spars. Be certain to check the locations carefully. Note in the front view on plan Plate 1, that 1/4"x1"x5-1/4" hardwood blocks should fit between the W1a and W1b ribs, and will rest on the ledges provided by the W3 ribs. However, the hardwood blocks cannot be glued yet. They will be added later after the basic wing structure is secure.

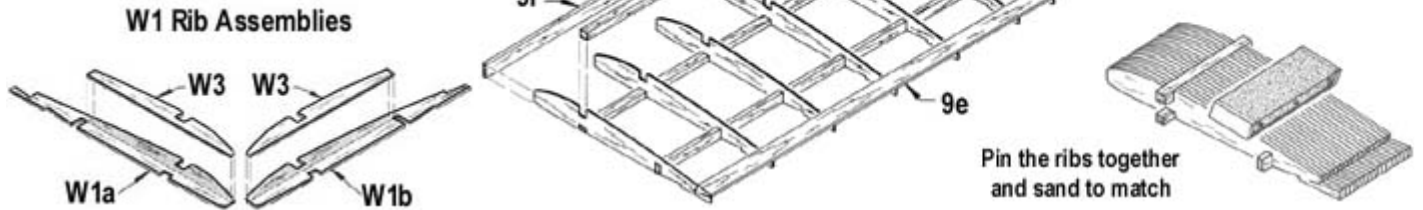

- d. Glue the remaining ribs to the spars. Sig-Bond glue is recommended.
- e. Fit the shaped trailing edge into the jig ledge on the back of the W1 ribs. Trim parts wherever necessary to make the trailing edge fit snugly against the ribs. Note that the 90 degree angled front corner of the trailing edge is placed up. (See rib cross-section drawings on the plan.) Check the position of the 1/16"x3/16" cap strips and center section planking on the ribs in relation to the trailing edge to be certain the trailing edge is positioned correctly on the ribs.
- f. Since there will be minimal gluing contact between the ribs and the trailing edge until the cap strips are installed add gussets to each rib to secure the trailing edge. Leave the gussets there - they will help to keep the trailing edge from yielding to the pull of the doped covering when shrinking.

- g. Add the 5/16" sq. top spars. Join in the center of the wing with epoxy.

- h. True-up the fronts of the ribs by sanding lightly with a long sanding block, preferably at least 24" long.

- i. Glue the 1/8"x1/2" leading edge to the front of the ribs.

- j. Trim and sand the top of the leading edge even with the tops of the ribs.

- k. Glue the 1/16" leading edge top sheeting in place. Use Sig-Bond glue and plenty of pins to hold it down securely until the glue is dry.

- l. Add the remaining 1/16" top sheeting.

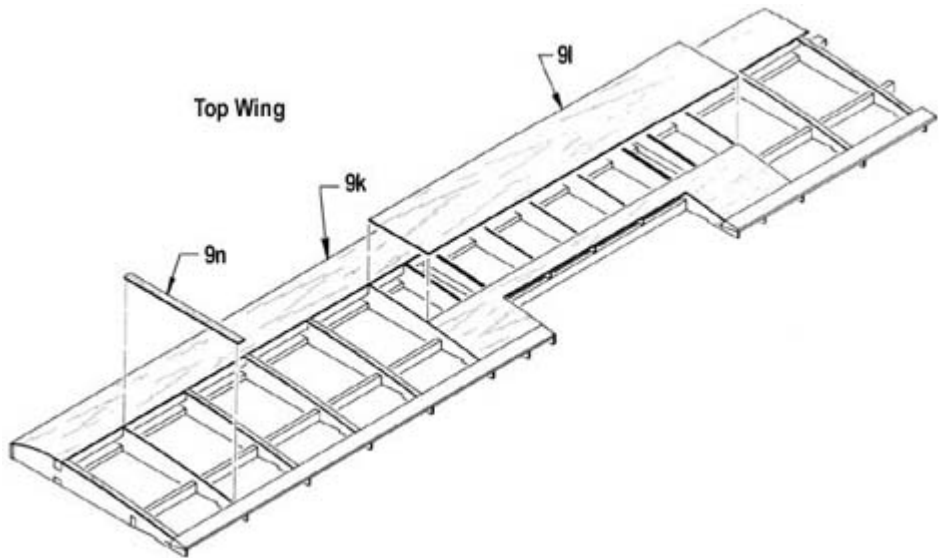

- m. Cut out the areas directly above the locations for the nylon wing bolt holes which will be drilled and tapped later.

- n. Add the top 1/16"x3/16" cap strips.

- o. When the glued joints are completely dry, remove the wing from the building board. Cut off the jig portions of the ribs. Trim or sand the bottom rear corner of the 3/16"x3/8" rear spar flush with the bottom of the ribs.

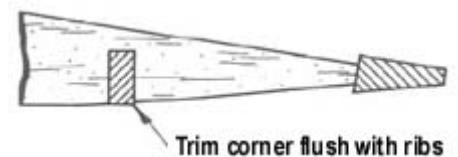

- p. Carefully cut away the 3/16"x5/16" bottom spar between ribs W1a and W1b. Epoxy the 1/4"x1"x5-1/4" hardwood insert blocks in place between ribs W1a and W1b. The blocks should rest tightly against the ledges provided by the W3 ribs.

- q. Add 1/16" sheeting to the bottom of the wing in the same manner in which the top sheeting was done. Cut away the bottom sheeting under the hardwood insert blocks where the cabane struts will attach. (See fuselage side view.)
- r. Sand the front of the wing leading edge with a sanding block. Glue the 3/16"x1/2" leading edge cap to the front of the wing. Carve to airfoil shape. (See rib cross-sections on plan.) Finish with a sanding block.

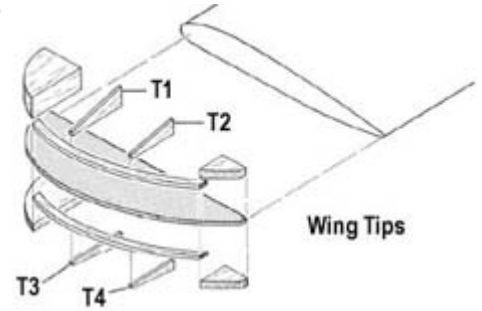

- s. Glue the die-cut wing tip plates to the end ribs.
- t. Add the front & rear, top & bottom tip blocks and the die-cut tip edge braces. NOTE: 3/4"x1-1/2"x2" is provided for the top/front blocks. The top/rear, bottom/rear, and bottom/front blocks are on the printed balsa sheets.

- u. Glue the tip braces T1, T2, T3, and T4 in place. T1 and T2 go on the top of the plate, and T3 and T4 go on the bottom.

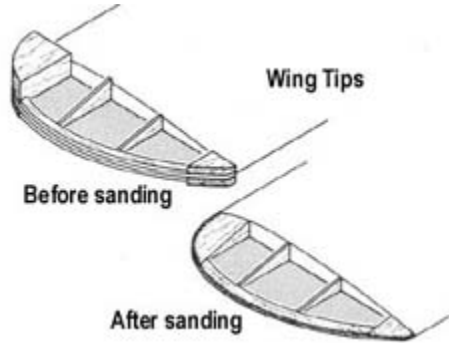

- v. Carve and sand the wing tips to shape. The blocks, braces, and edges are cut oversize to allow adequate shaping room. Check all applicable photos and drawings. Note that the tips taper in a straight line from the end rib to the edge of the wing tip plate.

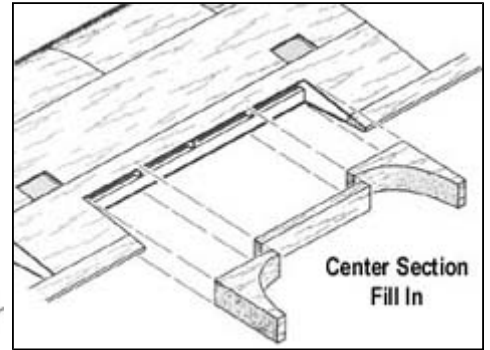

- w. Fill in the center section trailing edge with pieces of 3/4" balsa cut from the 3/4"x2-5/8"x4" block supplied. Carve and sand to wing contour and round the edges.

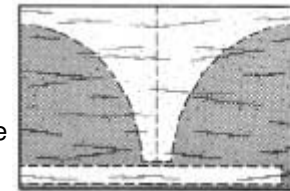

- x. Insert the 1/8"x3/8"x3/4" plywood 'N'-strut mounting plates into the bottom surface of the wing. Cut out the 1/16" balsa sheeting to install the front plates flush with the surface of the wing. The rear plates should be installed against the rear spar and flush with the surface of the cap strip.

- y. Sand the entire wing with a sanding block to prepare it for covering.

## 10. Cabane Struts

Patience and an extra hand to help hold parts in alignment will be needed to complete the next series of steps. The four 1/8" cabane strut wires and the two 1/8" cabane brace wires are pre-bent but some minor alterations may be necessary during assembly. The most critical point of the cabane strut assembly is to get the front and rear cabane strut wires set up parallel to each other. If they are exact, the 0 degree incidence of the top wing will be set accurately.

- a. Polish all wires clean and bright with sandpaper to insure good soldering. Clean the wires with thinner.
- b. Insert the four main cabane strut wires into the brass tubing mounts in the fuselage.

- c. Fasten the 1/8" brace in place by binding them to the cabane wires with copper wire. Hint: Clamp the 1/8"x3/4"x4-3/16" plywood strips between the top arms of the cabane wires while binding the braces in place to insure that the distance between the top arms will be correct and the cabane wires parallel.

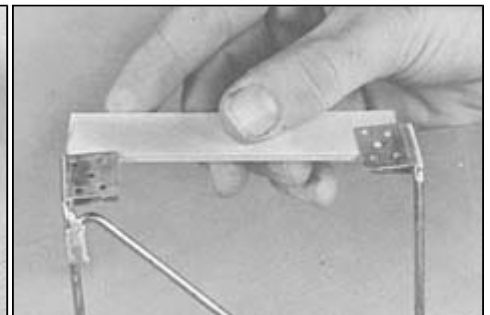

- d. When satisfied with the alignment of all the wires, solder the copper wire bindings. Use a good hot iron and sufficient soldering paste to flow the solder completely around and through the bindings.
- e. The 1/8"x3/4"x4-3/16" plywood strips are held to the upper arms by a brass strap. Drill some random glue anchor holes in the strap. Bend the strap around the arm of the cabane wire. Line up the straps with the plywood strips. Use tape or clamps to hold the pieces in position. Solder the straps to the arm. Remove the plywood strip and thoroughly clean the brass strap and wire with thinner. Glue the plywood strips to the brass straps. Use an even coat of epoxy glue on the inside of the strap. Smooth out the excess epoxy that oozes to the outside of the strap before it hardens.  
  
(Note: During the soldering operation, you may want to substitute a piece of scrap 1/8" plywood, cut to 4-3/16" long, for the good plywood pieces you will finally use. The soldering paste will soak into the plywood and may keep the epoxy glue from sticking.)
- f. After the brass straps are stuck down evenly to the plywood, use a sanding block to take down the worst high spots and smooth out any snags. Then cover the entire platform (meaning the plywood strip and brass straps) with a coat of epoxy glue.
- g. When dry, place the cabane struts in the fuselage and set the top wing in position. Check the alignment of the top wing with the fuselage carefully, especially from the front and top views. Measure from several places until you are satisfied that the alignment is correct. Hold the wing in position and drill through the cabane strut platform and hardwood insert blocks with a No.7 drill. Check the top wing plan for the approximate location of the holes. Avoid drilling into the 5/16" sq. top spar. Remove the wing and tap the holes in the hardwood inserts with a 1/4-20 tap. Enlarge the holes in the platform with a 1/4" diameter drill to pass the nylon wing bolts. Fill in the openings in the top sheeting above the wing bolts with 1/16" balsa.
- h. Epoxy pieces of 1/8" sq. balsa to the struts as indicated on the fuselage side view. Sand them to streamline shape. Fill in the open areas over the wires with Epoxolite putty.
- i. To permanently install the cabane struts in the brass tubing mounts, nick the wire at intervals with a file and glue them into the tubing with epoxy. However, it is easiest to cover and finish the fuselage before permanently gluing in the struts.

## 11. Bottom Wing Assembly

Note that the bottom wing is basically constructed in three sections - a flat center section, a right wing panel, and a left wing panel.

- a. Cut three 3/16"x5/16" bottom spar pieces and three 3/16"x3/8" rear spar pieces to length for the left, center and right wing panels. Pin to the plan.
- b. Glue all ribs in place on the spars except ribs WB.
- c. Fit the T.E. into the ledge on the right and left wing panel ribs and glue. Note that the 90 degree corner is up.
- d. Add 3/32" gussets to all WE ribs except the tip rib.
- e. Add top 5/16" spars to the right and left wing panels gluing to all ribs WC, WD, and WE. Note that the top spar extends into the center section but shouldn't be glued there yet.
- f. Add 1/8"x1/2" L. E. to right and left panels.
- g. When dry, unpin right and left panels and block up the tips 5/8" each. See front view drawing on Plate 1 of full size plans. Bevel the center section bottom and rear spars to fit tightly against the corresponding spars in the outer panels and glue in place.

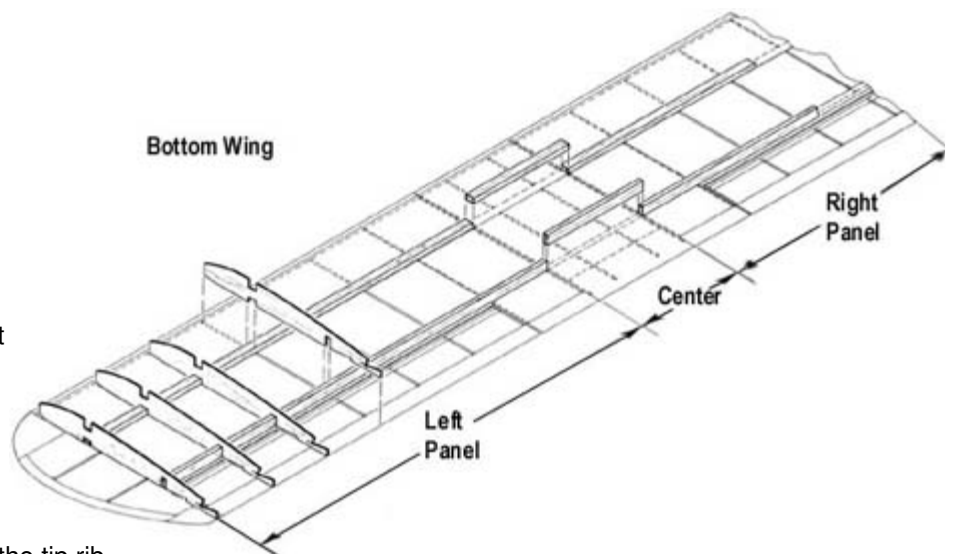

- h. Glue ribs WB to ribs WC and to the center section bottom and rear spars.
- i. Add 1/16"x1-1/2"x4" plywood to the bottom of the trailing edge of the center section. Do this without removing the wing from the board.
- j. Add 1/8"x1/2" L. E. to the center section.
- k. Add center section 5/16" sq. top spar doublers. Epoxy to all ribs WA, WB, WC and to the 5/16" sq. top spar.
- l. When the glued joints are completely dry, remove the wing from the building board. Cut off the jig portions of the ribs. Trim or sand the bottom rear corner of the 3/16"x3/8" rear spar flush with the bottom of the ribs.
- m. Trim and sand the L.E. to shape.
- n. Add scrap T.E. stock to fill in around wing bolt holes.
- o. Install all 1/16" L.E. and center section sheeting to the top and bottom of the entire wing. Leave off the top planking directly over the areas where the torque rods will be installed.
- p. Sand the front of the L.E. with a sanding block. Add the 3/16"x1/2" L.E. cap and carve to shape. Finish with a sanding block.
- q. Add the 1/16"x7/8" strips to the top of the wing at the location shown.

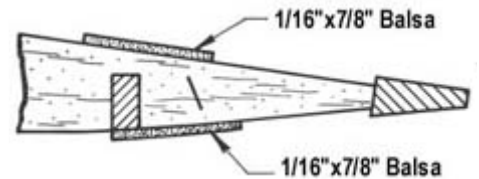

- r. Glue the aileron end ribs WF in place from the bottom of the wing. Also glue in the WG ribs.

- s. Install 3/32" gussets against the WF ribs.
- t. Add 1/16"x7/8" strips to the bottom of the wing.
- u. Cut and glue 1/16"x3/16" cap strips on the top and bottom of the entire wing.
- v. Assemble and shape the bottom wing tips in the same manner as you did the top.
- w. Install 1/8"x3/8"x3/4" plywood "N"-strut mount plates flush with the top of the wing at the locations shown on the plan.
- x. Sand the entire wing carefully with a sanding block.

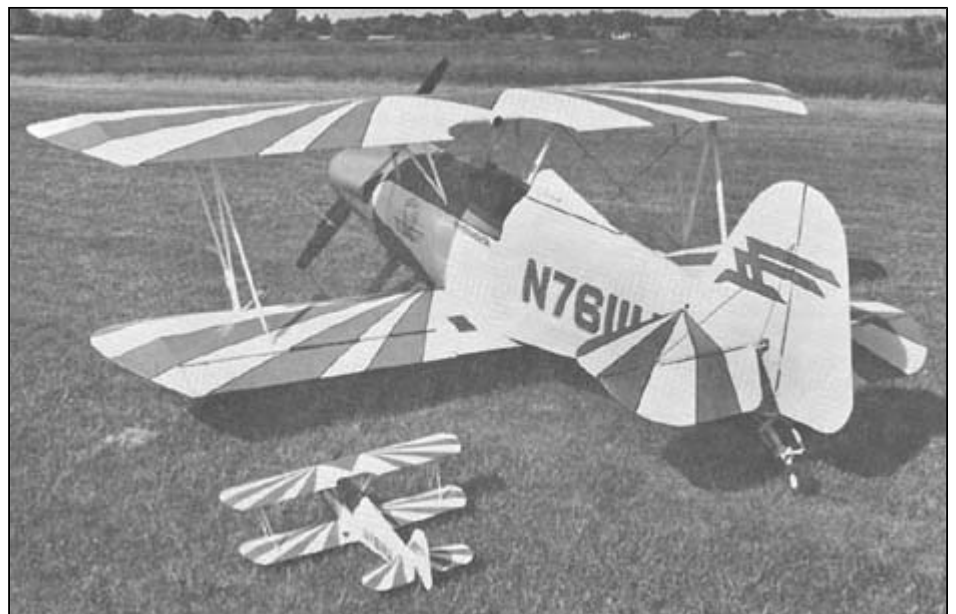

Glen Sig's Smith Miniplane and the first prototype model at Sig Field.

## 12. Ailerons

(See illustration sequence on the plan.)

- a. Locate the rear spar under the 1/16" x 7/8" strips. Draw guide lines on both the top and bottom strips about 1/32" behind this spar so that there is no danger of cutting into the spar in the next step.
- b. Cut through the planking strips on the guide lines with a sharp knife.

- c. Remove the blade from a X-Acto razor saw by prying apart the crimped metal backing with a screw driver. Insert the blade into the slits just cut into the planking and saw through each of the ribs of the aileron.
- d. Saw through the trailing edge and remove the ailerons.
- e. Trim and sand the back of the wing cut out so the planking is flush with the back of the rear spar.
- f. Cut thru the ailerons in line with the die cut slits in the ribs. Use a sanding block to straighten the front and ends of the ailerons.

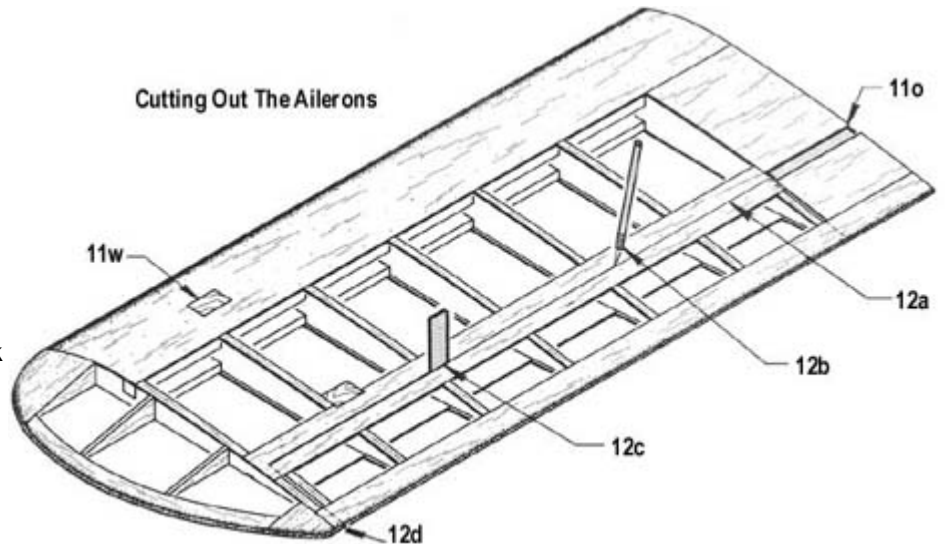

- g. Glue 1/8"x3/4" balsa to the wing opening and to the aileron front as shown on the plan. Trim and sand the pieces to wing contour.
- h. Cut slots in the aileron leading edges and notch wing ribs WA, WB, WC and WD to accept the torque rods.
- i. Epoxy the hinges into the ailerons. Check the operation of the ailerons by dry fitting them to the wing to make sure there is no binding before gluing (1) the hinges into the wing, (2) the torque rods into the ailerons, and (3) the brass bearings to the ribs.
- j. The torque rod bearings should be just below the surface of the wing. Carefully shape the edges of the 1/16" sheeting to close the gap over the bearing. Glue the sheeting in place and sand to blend smoothly into the wing contour.

### 13. Mating The Bottom Wing To The Fuselage

- a. Sand the fuselage wing cutout to match exactly the contour of the wing. The wing leading edge should fit tightly against FII. Hold the bottom wing firmly in place, and check the alignment with the top wing and fuselage. Look from the front and top views. Measure to see that the distance between the tips of the wings is the same on both sides. If not, sand the wing saddle on the appropriate side until the bottom wing will line up correctly.
- b. Glue the hardwood wing bolt blocks to the inside of the fuselage. Brace them with 1/2" triangular balsa. To complete the fuselage around the wing cutout, add the 1/8" sheet balsa bottom between the wing blocks and the main frame.
- c. Place the wing in the fuselage against FII. Mark and drill a 1/4" hole in the center of the leading edge so that the dowel to be installed in it will hit the approximate hole shown in the pattern of FII. Remove a piece of the wing sheeting large enough to allow easy access to the dowel area. Save the piece so that it can be glued back on after installation and reinforcement of the dowel.

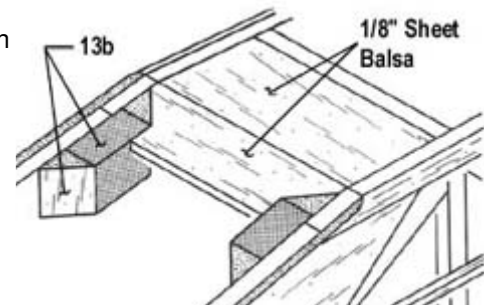

- d. Push the 1/4"x1-1/4" dowel into the hole until only about 1/16" protrudes. (Note: This is temporary for checking purposes only. When finally glued in place the dowel should stick out about 1/4".) Hold the wing in place and mark the spot where the end of the dowel hits FII. Remove the wing and drill a 1/4" diameter hole in FII at the marked spot.
- e. Put the wing back on. It is probable that the dowel alignment with the hole isn't perfect. Enlarge the dowel hole in the wing as required so that the wing will fit snugly against the fuselage. Plug the enlargement with scrap slivers. Epoxy the dowel into the wing with about 1/4" protruding from the leading edge. Before the epoxy sets up, hold the wing in place on the fuselage, with the dowel sticking into FII. Be careful not to let the glue ooze out of the dowel hole into FII. Use only a small amount of glue since it can be glued additionally once the alignment is set. When the epoxy sets up, remove the wing and surround the dowel inside with scrap balsa, bracing it against the bottom sheeting. Replace the top sheeting that was removed to provide access to the dowel area.

- f. Hold the wing in position and locate the proper spots on the bottom of the wing to drill through to hit the hardwood wing blocks in the desired location. Drill through the wing and anchor blocks with a No.7 drill. Tap the hardwood blocks with a 1/4-20 tap. Enlarge the holes in the wing to pass the nylon wing bolts by drilling through them with a 1/4" diameter drill.

## 14. N-Struts

Construction and fitting of the N-struts require the completed wings and fuselage.

The N-struts are functional - they link the top and bottom wing panels together into a single structure greatly increasing the strength of both. Straight pieces of 1/16" diameter wire are provided to link the wings securely. The wires will be streamlined with balsa wood. Note how the struts are fastened to the plywood plates in the wings by means of a brass foot soldered to the 1/16" strut wire. The foot is then held to the plywood plate by a small screw.

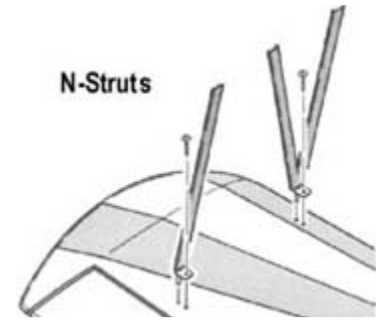

- a. Drill a 1/16" diameter hole in each of the 1/8" plywood strut mounting plates in the wings. Locate the holes as shown on the plan. Notice that the location differs between the top wing and the bottom wing.

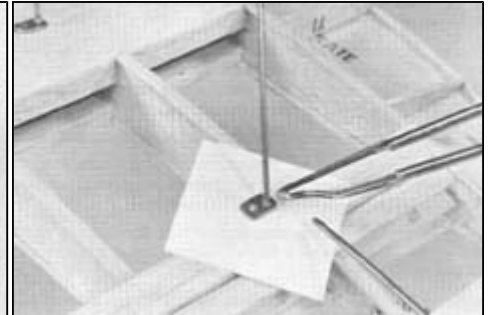
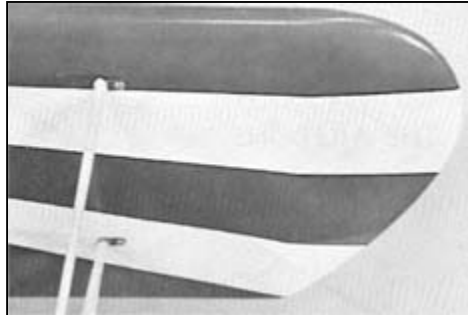

- b. Assemble the top and bottom wings to the fuselage.

- c. Bend the ends of the 1/16" strut wires as required to allow them to plug straight into the holes.

- d. Cut out eight brass feet from the 1/4" wide brass strip provided. Round the corners and remove any burrs with a file and sandpaper. Drill holes in each foot as shown on the plan.

- e. Carefully solder the brass feet to the 1/16" strut wires. The wires should be installed between the wings during soldering to achieve good alignment of the feet to the plywood plate. (See photo)

- f. Drill a pilot hole to allow the No.2 screw to thread into the plywood mounting plate.

- g. Use epoxy glue to attach the 1/8" sq. balsa fairing strips to the wires and to glue the 1/8"x5/16" balsa stick connecting the struts. Shape the strut fairing balsa by carving and sanding all of the corners round. Fill in the open areas over the 1/16" wire with Epoxolite putty. Reinforce the strut balsa joints with a layer of fiberglass cloth and epoxy where it is indicated on the plan.

## 15. Attaching The Tail Surfaces

- a. Remove the covering material from the bottom center of the stab. to allow a wood to wood joint, where it will contact the fuselage.

- b. With the wings mounted to the fuselage, pin the hinged stab/elevator assembly in place. Note that the fuse may need to be trimmed slightly under the elevator dowel to permit adequate movement of the elevators. Carefully align the stab with the wings from the top and front views. Mark the location of the fuse on the top and bottom of the stab center section. Remove the stab and apply epoxy glue. Slow drying (not 5-minute) is recommended to allow adequate time to get the stab in exact alignment before the glue hardens. Pin the stab back in place using the markings to get it in approximate alignment. Before the glue hardens, recheck the alignment carefully by measurement and shift the stab position slightly if necessary.

- c. Epoxy the fin/rudder assembly in place - align carefully.

- d. Shape the 3/4"x1"x5-1/8" tail fairing blocks and glue in place.

- e. Fill in the space in front of the stab leading edge with scrap balsa.  
Note: The fuselage/fin fairing piece R5 should be added after the fuselage is covered.

## FINISHING AND FLYING

The photo of Glen's Smith was constructed in 1967 by Billy Simpson of Jerseyville, ILL. His expert workmanship is evident by the dazzling, high gloss red, white, and black paint job. The Miniplane's construction is typical of many home-built designs - with steel tube, fabric covered fuselage and tail surfaces; wood and fabric wings; metal cowl; and fiberglass wheel pants.



### 16. Sanding And Painting Plastic Parts

All of the ABS plastic parts should be sanded to remove the gloss on the surface of the plastic before they are painted. Avoid using coarse sandpaper which can deeply scratch the plastic.

Deep scratches can open up during doping and become prominent. Use something like 220 grit 3M Tri-M-Ite Free Cut Finishing Paper (See Sig Catalog). Polish down the first sanding with 360 grit Free Cut Tri-M-Ite or 400 grit Wet-Or-Dry paper before color doping.

The plastic parts may be brushed or sprayed with Sig Supercoat color dope. Care should be taken not to apply heavy, wet coats of color dope to the plastic. Put on light coats and allow them to dry thoroughly before applying a second coat.

The ABS plastic parts may also be painted with K&B Super Poxy, Hobbypoxy, or DuPont Dulux Enamel. Do not use other paints, dopes or finishes without first testing on scrap plastic to make certain they are compatible with the plastic.

NOTE: Do not try to cover any of the plastic parts with monokote or other iron-on types of covering material. The heat can damage the plastic parts.



### 17. Covering And Painting

The Miniplane should be covered with silk, or other cloth material, rather than silkspan, due to the large unplanked areas. Remember that covering and paint won't cover up poor workmanship - Be sure all surfaces are smooth. After the final sanding of the finished framework give it two coats of unthinned dope wherever you want the silk to adhere to the framework. Give these areas another final, light sanding. Apply the silk wet but do not stretch too tightly, as it will only encourage warping later on. Pull the silk up just enough to get out all the slack and wrinkles. Paint dope around the edges. This will soak through and adhere to the pre-doped framework. Let dry before trimming with a sharp razor blade. Check for any spots that are not stuck down and apply more dope.

Next give the entire airplane three coats of Supercoat Clear Dope or Lite-Coat Low Shrink Clear Dope. Thin the dope until it brushes on easily and flows out smoothly. Brush on the first coat over the open areas sparingly. As the brush rubs across the ribs, dope is rubbed off the brush and through the silk and will run down the ribs inside. As excessive amount will run completely through the framework and puddle against the covering surface on the other side. When these puddles dry, the large amounts of dope solids in them causes more shrinkage than in the rest of the covering and a scarred area results. So apply dope very lightly the first time over. A second coat should seal most of the pores of the silk and from this point, running through will not be a serious problem.

A fourth or fifth coat of dope may be necessary, depending on how heavy a coat is applied, to completely fill the silk grain. The ideal is a completely smooth and even base.

Keep in mind that weight can build up fast in finishing and restraint must be used in application. Sand lightly with 220 grit Tri-M-Ite paper between the later coats of dope. Don't bear down on the edges of the balsa structure or the silk fibers will be cut.

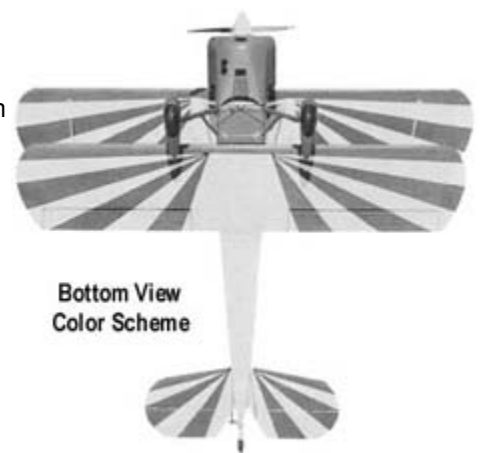



If possible, best results can usually be obtained by spraying on the color finish coats. Reduce the dope for spraying fifty-fifty with Supercoat Thinner. Two or three coats of your base color should give good coverage if the surface preparation was sufficient. The following steps outline the finishing coats that were used on the prototype models to duplicate the color scheme of Glen Sig's Smith.

Spray three coats of Brilliant White Supercoat Dope on the entire airplane including the plastic parts. Refer to previous section for notes on painting the plastic parts.

When dry, mask off the edges of the red trim color areas with Drafting Tape (3M Scotch brand is available at most office and art supply stores). Completely cover with paper and tape all areas that should remain white. Use heavy, close grained paper (not newsprint, etc.). Brush or spray the edges of the drafting tape with clear dope. This seals the tape, preventing leakage of the red trim color underneath the tape. Spray on two coats of Light Red Supercoat Dope. When dry, carefully remove the tape.

Spray on a coat of clear dope to protect the colors from scuffing and to give the entire color scheme a uniform gloss.

The black pin stripes along the red and white color separation lines were put on at this point using a #5 technical drafting pen (Rapid-a-Graph or Castell) and black drawing ink. You must spray several more light coats of clear dope over the ink lines, after they are dry, in order to make them fuel proof and permanent.

## 18. Completing The Cockpit

- a. Trim the cockpit opening to final shape using the full size pattern provided below as a guide. A piece of black rubber tubing is provided for simulating the cockpit edging. With a sharp single edge razor blade, slit the tubing lengthwise along one side so that it can be opened and slipped over the edge of the 1/8" balsa cockpit rim. Use epoxy glue to permanently fasten the tubing in place.

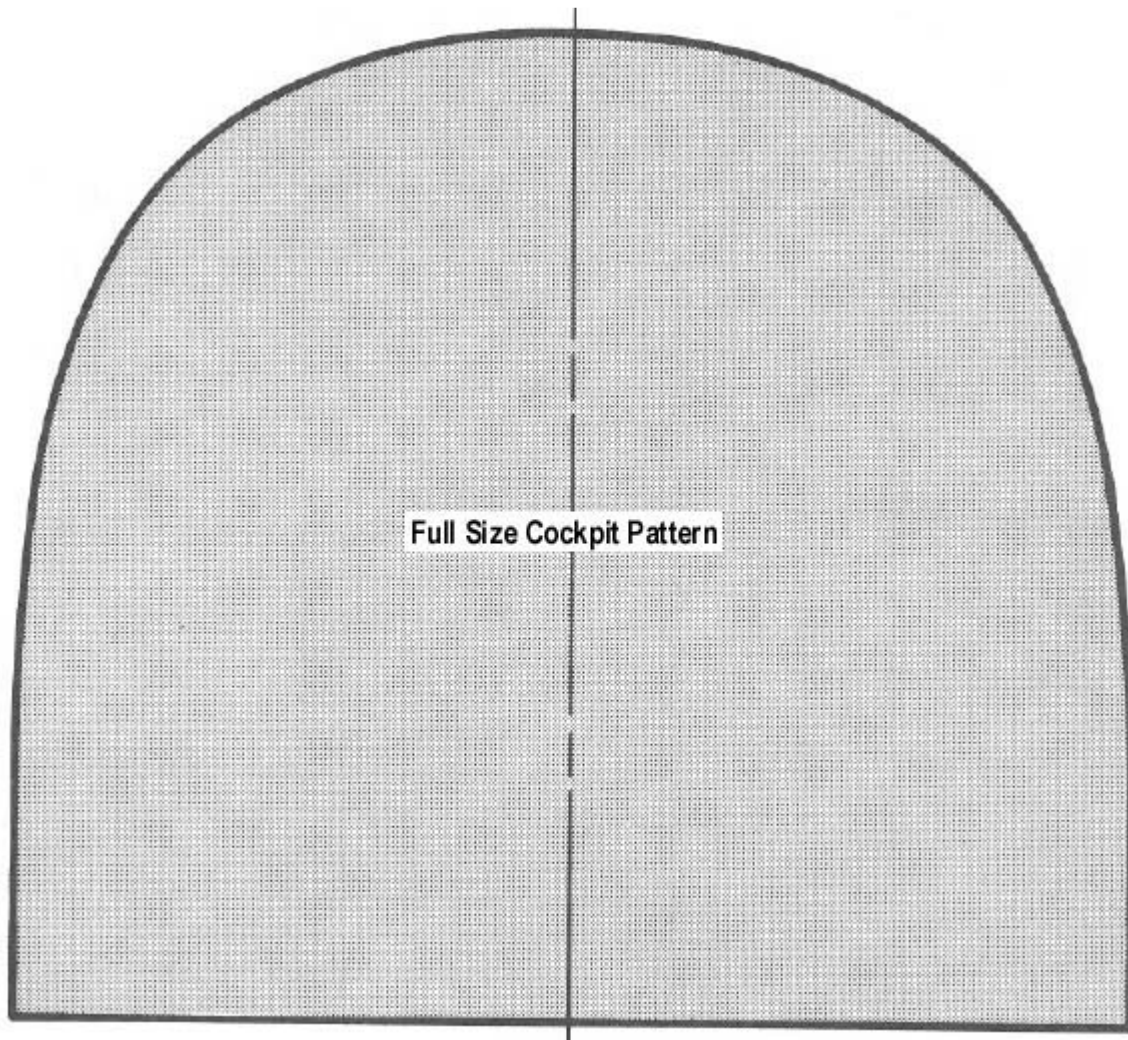

- b. Sand the bottom of the ABS plastic headrest as necessary to get a good fit on the top of the fuselage. Glue it in place on the top of the fuselage. Glue it in place with Sig-Ment, used sparingly. Paint the headrest Brilliant White - refer to Sanding and Painting Plastic Parts section.
- c. Cut the windshield from clear plastic sheet, using the pattern on the plan. Fasten it to the model with SigMent glue. The cyanoacrylate adhesives (Hot Stuff, Jet, Zap, etc.) also work well for attaching the windshield since they bond almost instantly. Cover the glue seam with a strip of vinyl plastic to simulate the windshield attachment strip of the full size airplane.

**Cockpit of the Prototype Model**

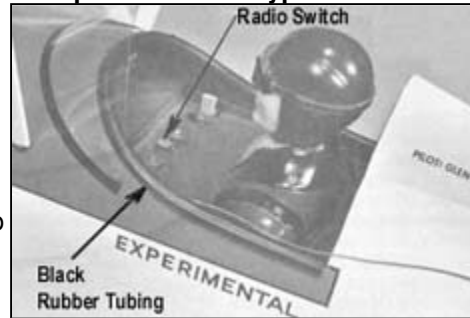

**Cockpit of the Full-Size Miniplane**



Williams Brothers 2-5/8" Scale Standard Pilot is recommended for the Smith Miniplane.

## 19. Decals

### Instructions For Dry Application:

Cut the decal from the sheet with scissors or a sharp modeling knife. Trim close to the image, leaving about 1/32" to 1/16" of clear edge. Peel the backing sheet from about half of the decal because after it is in place it is very difficult to move. Once it is in place, press down on the edge and carefully work toward the half which does not have the backing sheet removed. Continue to peel off the backing sheet as you press the decal into place, being careful not to trap air under the decal. If an air bubble is trapped under the surface, puncture it with a pin and press the decal down on the surface. Rub with a soft, dry cloth to make certain it is sealed to the surface.

### Instructions For Wet Application:

Cut out the decals with a pair of sharp scissors. Leave about 1/32" to 1/16" of clear edge around the decal. Round the corners as you are cutting. Wet the surface on which the decal will be placed with soapy water (use dishwasher detergent). Peel the decal film from the backing sheet. Place the decal on the model and squeegee the water from underneath with a balsa paddle. Allow to dry. This procedure will prevent air from being trapped underneath as is possible when the decals are applied dry. It also permits shifting it to exact position during application. Decals applied dry cannot be moved after they are pressed on.

## 20. Tank Installation

Use a 8 or 10 ounce rectangular plastic clunk tank. A side mounted engine installation is recommended. The plan shows the correct position of the tank for proper fuel draw and idle characteristics. Assemble your tank as shown in the photo with three outlet tubes - 1 fuel feed and 2 vents to allow refueling without removing the fuel feed line at the carburetor. Both vent tubes should curve upwards inside the tank. Drill a group of three holes in the firewall large enough in diameter to pass the tank outlet tubes with fuel line tubing installed.



Install the tank semi-permanently with cross-pieces of plywood or balsa to hold it in place. If the tank is equipped with an internal fuel line cut from Sig Heat Proof tubing it can be left in the fuselage indefinitely since this line will not harden when immersed in fuel. Seal the outlet holes in the firewall against leakage of exhaust oil into the fuselage with G.E. Silicone Seal or equivalent silicone rubber sealer. Should the need arise to remove the tank, break away the wood supports and bathtub seal and pull the tank out through the lower wing opening.

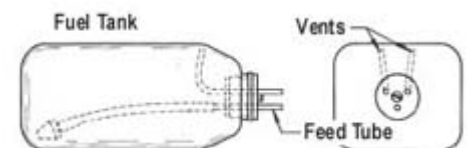

## 21. Radio Installation Notes

NOTE: No servo Mounting Material or Hardware is supplied in this kit.

The most convenient method of installing servos is on the plastic mounts which most of the radio equipment makers offer with their outfits or as an accessory. These are screwed to hardwood mounting rails for fuselage servos or to hardwood blocks for mounting in the wing. Instructions for the use of these mounts are included with them.

Servos for which plastic mounts are not available can be screwed directly to at least 3/8" square hardwood rails placed across the cabin as shown in the accompanying drawing. With rubber grommets installed in the servo mounting holes, mark the spots for drilling the pilot holes for screws. Space the servos at least 1/8" apart and do not have them contacting the hardwood mounting rails except on the grommets. Using a washer on the wood screws, mount the servos to the rails. Do not tighten the screws down against the grommets since this will cause vibration to be transferred to the servos. The washer should just rest against the grommet without compressing it.

The receiver battery pack should be wrapped in foam rubber sheet, held on with rubber bands or masking tape. Place in as far forward in the fuselage as possible, preferably under the tank. It is a good idea to put the package in a small plastic bag, taped shut around the battery cable to protect the battery from accidental fuel leakage.

The receiver should be similarly wrapped up in foam rubber to protect it from engine vibration. Cover it with a plastic bag also. Stow this completed package in front of the servos. Make certain that the receiver will stay in place during aerobatic maneuvers.

The switch may be mounted wherever it is convenient on the side of the model, preferably the side away from the engine oil. Another good spot is inside of the cockpit where it may be reached easily. (See photo in "Completing The Cockpit" section 18.)

"Brick" type receiver and servo combinations will have to be mounted on rails as specified by the manufacturer of the radio equipment.

### Typical Radio Installation

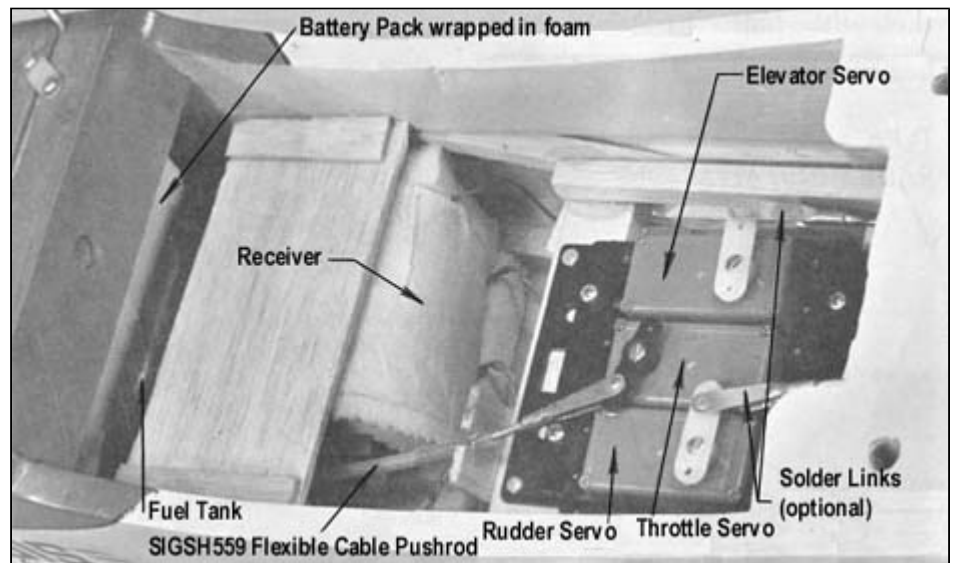
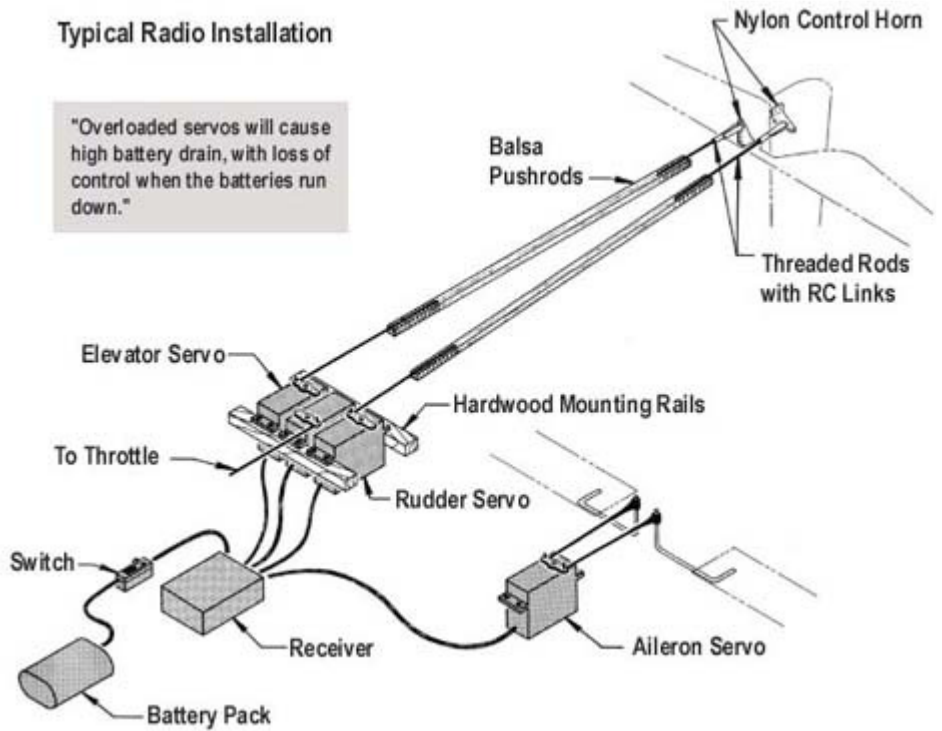

"A model, engine or radio that is not prepared and working properly on the ground before takeoff will not improve in the air---IT WILL GET WORSE! 'There is no point in attempting to fly until everything is 100% correct."

The output arms of some servos will take 1/16" wire or the pin in a RC link clevis without it being necessary to enlarge the hole. The fit will be snug but usually will not be tight enough to cause too much friction and put a load on the servos. Should it appear to be too tight, drill the holes out with number size drills only, selected carefully. A No. 51 is about right, no larger than a No. 50. An overly large hole will cause control surface slop and flutter. After installation is complete, operate all controls to full movement and listen to the servos. If overloaded, they will probably buzz or hum.

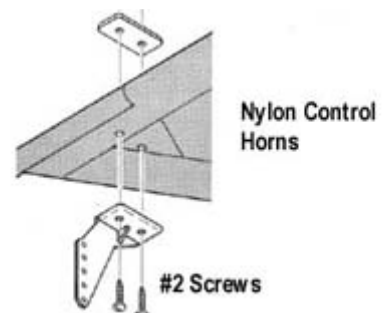

Another sign of excess load on the servo is a pushrod that sticks or reaches the end of its travel before the servo does and bends or arches up 'or down from the servo pushing it against a deadend. Locate the cause of overloads and eliminate them. Overloaded servos will cause high battery drain, with loss of control when the batteries run down. Servos may be damaged by continual overload.

**Double check all Control Hookups - No Binding, Rubbing, or Sticking**

NOTE: Some RC sets have one reverse direction servo that will require an opposite hookup than that shown here for logictrol radios.

**22. Pushrods**

A flexible steel cable pushrod with nylon outer tubing (SIGSH559 or DuBro No. 165) is recommended for hookup of the throttle to the motor servo.

5/16" square balsa sticks are provided to make the fuselage pushrods that run to the elevator and rudder. Bind the fittings to each end with heavy thread and epoxy glue. Use threaded rods with RC links at the tail end of the pushrods so that trimming adjustments can be quickly made. Straight pieces of 1/16" diameter wire are provided for the other end of the pushrods to allow hookup with the servo arm. A variety of quickly detachable pushrod retainers (Rocket City #07, SIGSH84, or solder clevises) are available from the Sig Catalog for securing the pushrod wires to the servos. Or you can make a "Z" bend in the end of the wires as shown.

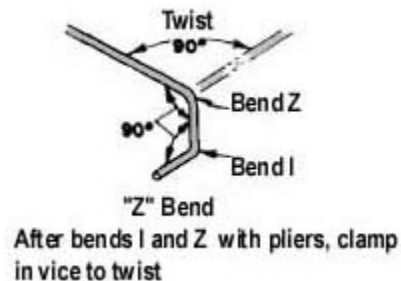

The aileron pushrods are threaded rods with RC links - cut off and connected to the servo output arm by one of the methods described above for the servo end of the fuselage pushrods. DuBro No. 103 or Rocket City No, 05 strip aileron horn wire connectors are suggested to link the aileron pushrods to the wire torque rods.

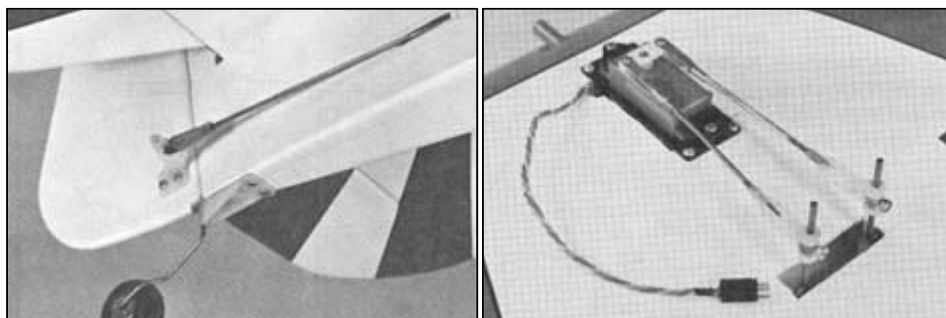
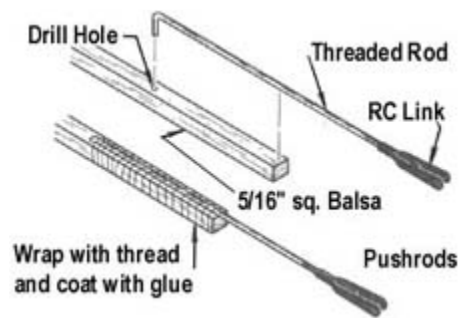

**23. Muffler Installation Notes**

The prototype models of the Miniplane used the Tatone Side Mounted Manifold #EM-SS. If fits completely inside the cowl and neatly directs the exhaust out two rubber tubes exiting thru the bottom of the cowl. It muffles adequately and doesn't detract from the scale appearance of the model. Since the construction of the prototypes, Tatone has introduced the #EM-40S, a slightly smaller version manifold for .40 size engines. If you are using a .40 engine, the #EM-40S would be our first recommendation. If you've got a .45 engine, you should get the #EM-SS.

PROTOTYPE INSTAIIATION  
Enya .45 and Tatone #EM-SS Manifold.



Large expansion chamber, flow-thru, or stack (DuBro MuffL-Aire) mufflers will require an extension to locate completely outside of the cowl.

**24. Pre-Flight**

Balance the model at the C.G. point indicated on the plan. If it balances further back, add lead to the nose as necessary. Trying to fly with the C.G. too far back is much more dangerous than the slight increase in wing loading caused by adding lead to the nose. Balance with an empty fuel tank. When slightly nose heavy the model is much more stable and less likely to snap roll or stall. The reaction to control movements is less sensitive so its not as easy to over control.

Be certain to carefully range check your radio equipment and see how it operates with the engine running before attempting test flights. A lot of problems can be avoided if the engine has been well broken in and the idle adjustment perfected on a test block or in another airplane before installation in the model.

A properly balanced and aligned model with a reliable engine and radio is assured of successful flights.

## 25. Flying

If you are a newcomer to model flying it is suggested that you not attempt flying without the assistance of a modeler with experience. Contact your local club or ask your hobby dealer for the names of good fliers in the vicinity and a suitable location for flying. Many hours of work are involved in the construction of a model and it can all be lost in a moment of beginner's indecision. A skilled flier can help you get past the first critical test and trimming flights without damage to the model and give instruction in proper control.



Hold a small amount of up elevator during the first part of the takeoff to keep the tailwheel steering effective until air speed is high enough for the rudder to take over. The model will drift to the left from torque during takeoff. Feed in some right rudder as soon as the tail wheel clears the ground, earlier if required. The model is not difficult to manage in the air and can be flown by anyone who is capable of handling a multi-channel model.



Empty Weight: 662 POUNDS  
Gross Weight: 1000 POUNDS  
Fuel Capacity: 17 GALLONS  
Oil Capacity: 5 QUARTS  
Wing Area: 100 SQ. FT.  
Stabilizer Area: 8.22 SQ. FT.  
Elevator Area: 4.86 SQ. FT.  
Fin Area: 3.02 SQ. FT.  
Rudder Area: 3.89 SQ. FT.  
Wing Span: UPPER 17' LOWER 15'9"  
Length: 15'  
Dihedral: UPPER 0°, LOWER 2°  
Wing Loading: 10 LBS / SQ. FT.  
Power Loading: 9.3 LBSIHP.  
Maximum Baggage: 10 POUNDS

Date of Certification: April 1967  
Registration Number: N7611U  
Model: SMITH DSA-1  
Serial Number: 101S

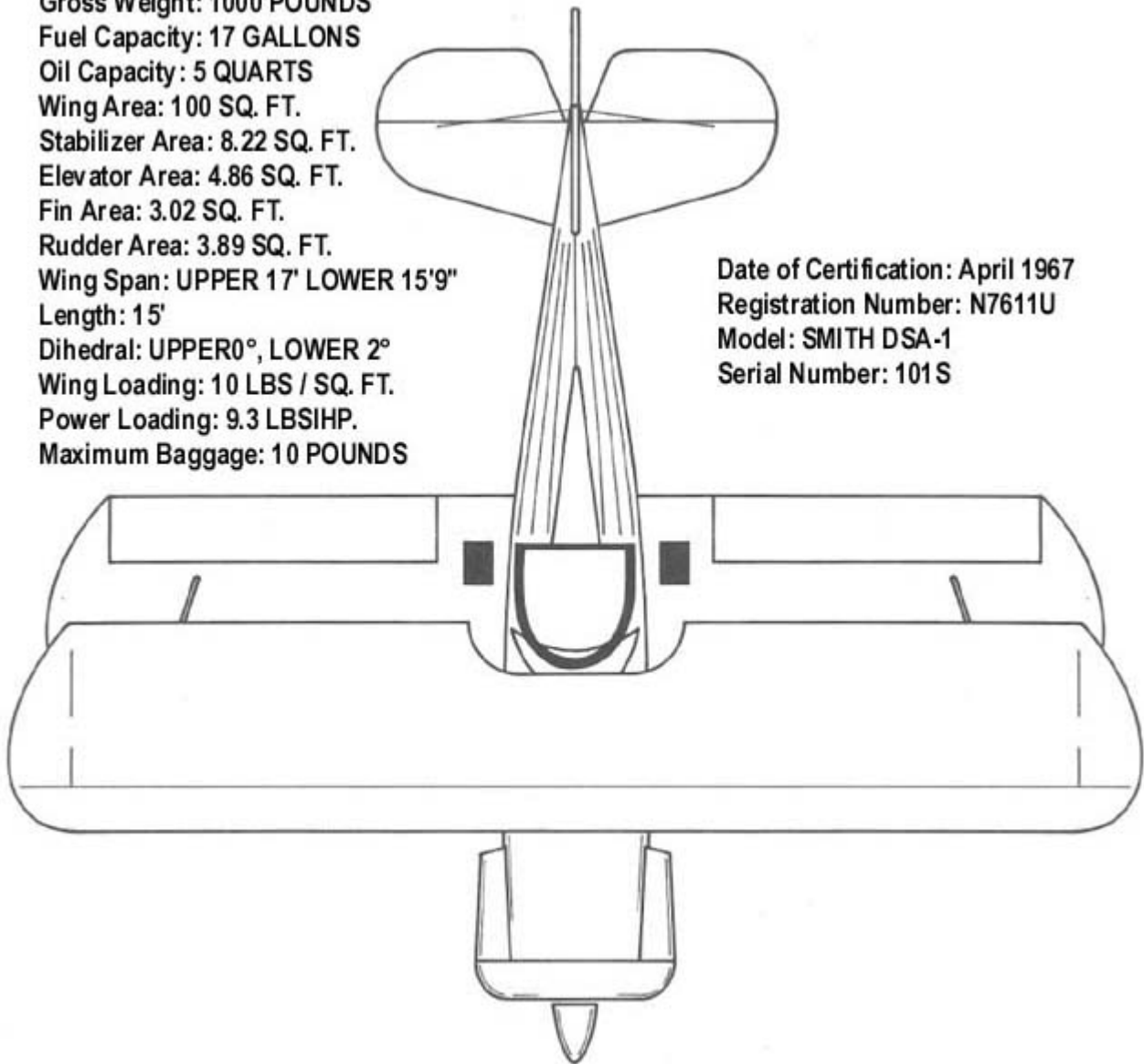

---

© Copyright SIG Mfg. Co., Inc.

**SIG MFG. CO., INC.....Montezuma, Iowa 50171-0520**

**LIMIT OF LIABILITY:**

In use of our products, Sig Mfg. Co.'s only obligation shall be to replace such quantity of the product proven to be defective. User shall determine the suitability of the product for his or her intended use and shall assume all risk and liability in connection therewith.