

Radio control model / Flugmodell

INSTRUCTION MANUAL / Montageanleitung

SPACE WALKER

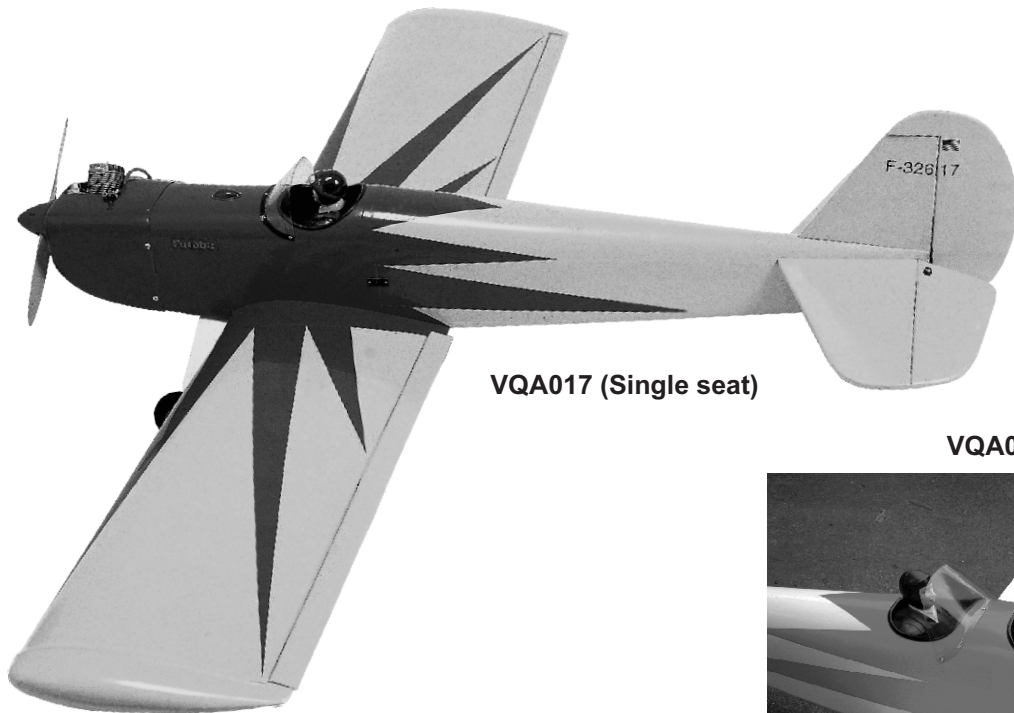

VQA017 (Single seat)

VQA018 (Two seat)



SPECIFICATION

Wingspan	1580mm
Electric Motor	870 Watt
Glow Engine	7.5cc 2T / 8.5cc 4T
Radio	5 Channel / 5 Servos

TECHNISCHE DATEN

Spannweite	1580mm
Elektroantrieb	870 Watt
Verbrennerantrieb	7.5cc 2T / 8.5cc 4T
Fernsteuerung	5 Kanal / 5 Servos



WARNING! This radio controlled model is NOT a toy. If modified or flown carelessly it could go out of control and cause serious human injury or property damage. Before flying your airplane, ensure the air field is spacious enough. Always fly it outdoors in safe areas and seek professional advice if you are unexperienced.

ACHTUNG! Dieses ferngesteuerte Modell ist KEIN Spielzeug! Es ist für fortgeschrittene Modellflugpiloten bestimmt, die ausreichende Erfahrung im Umgang mit derartigen Modellen besitzen. Bei unsachgemäßer Verwendung kann hoher Personen- und/oder Sachschaden entstehen. Fragen Sie in einem Modellbauverein in Ihrer Nähe um professionelle Unterstützung, wenn Sie Hilfe im Bau und Betrieb benötigen. Der Zusammenbau dieses Modells ist durch die vielen Abbildungen selbsterklärend und ist für fortgeschrittene, erfahrene Modellbauer bestimmt.

REQUIRED ITEMS / Zum Betrieb wird benötigt

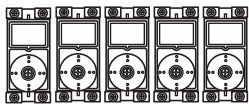
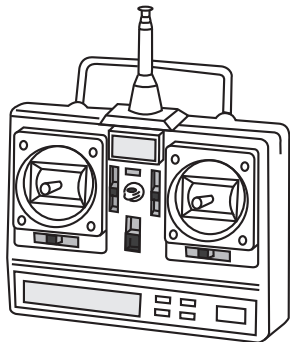

Minimum 4 channel radio for airplane with 4 servos
 .Motor control x1 .Aileron x2
 .Elevator x1 .Rudder x1



11x6 for 7.5cc - 2 cycle engine
 11x7 for 8.5cc - 4 cycle engine
 12x7~ 13X6 for Brushless Motor

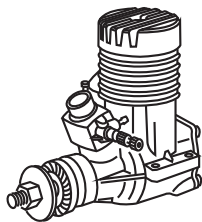

7.5cc 2T



Silicone tube

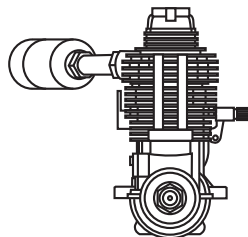

8.5 ~ 10cc 4T

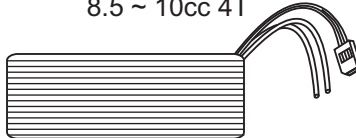

Li-Po Battery 18.5V, 4500mAh

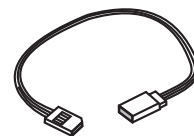

Extension for aileron servo

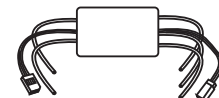

60A Brushless ASC
 60A Brushless Regler

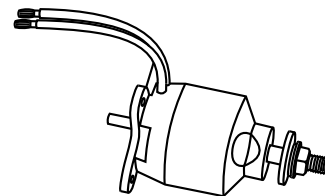

870 Watt
 Brushless Motor

GLUE / KLEBSTOFF



Silicon sealer

Cyanoacrylate
 Glue



Epoxy Glue (5 minute type)
 Epoxy Glue (30 minute type)

Hobby knife



Needle nose Pliers

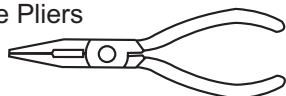

Sander

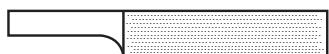

Phillip screw driver



Scissors

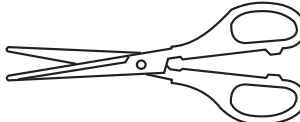

Hex Wrench



Awl



Wire Cutters

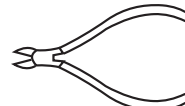



Masking tape - Straight Edged Ruler - Pen or pencil - Rubbing alcohol - Drill and Assorted Drill Bits

If exposed to direct sunlight and / or heat, wrinkles can appear. Storing the model in a cool place will let the wrinkles disappear. Otherwise, remove wrinkles in covering film with a hair-dryer, starting with low temperature. You can fix the corners by using a hot iron.

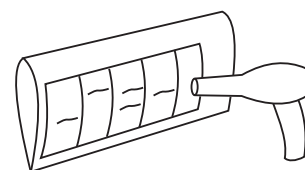
Bei Sonneneinstrahlung und / oder Wärme kann die Folie erschlaffen bzw. Falten entstehen. Verwenden Sie ein Warmluftgebläse (Haartrockner) um evtl. Falten aus der Folie zu bekommen. Die Kanten können Sie mit einem Bügeleisen behandeln. Nicht zuviel Hitze anwenden





 Drill holes using the stated size of drill (in this case 1.5 mm Ø)

 Take particular care here

 Hatched-in areas: remove covering film carefully

 Check during assembly that these parts move freely, without binding

 Use epoxy glue

 Apply cyano glue

 Assemble left and right sides the same way.

 Not included. These parts must be purchased separately

 1.5mm Löcher bohren mit dem angegebenen Bohrer (hier 1,5 mm)

 Hier besonders aufpassen

 Schraffierte Stellen, Bespannfolie vorsichtig entfernen

 Während des Zusammenbaus immer prüfen, ob sich die Teile auch reibungslos bewegen lassen

 Epoxy-Klebstoff verwenden

 Sekundenkleber auftragen

 Linke und rechte Seite wird gleichermaßen zusammengebaut

 Nicht enthalten. Teile müssen separat gekauft werden.

Read through the manual before you begin, so you will have an overall idea of what to do.

CONVERSION TABLE

1.0mm = 3/64"	3.0mm = 1/8"	10mm = 13/32"	25mm = 1"
1.5mm = 1/16"	4.0mm = 5/32"	12mm = 15/32"	30mm = 1-3/16"
2.0mm = 5/64"	5.0mm = 13/64"	15mm = 19/32"	45mm = 1-51/64"
2.5mm = 3/32"	6.0mm = 15/64"	20mm = 51/64"	

1

Thread for aileron servo extension

Cut the hole for the aileron servo extension exit.
Adhesive tape

1-Cut the hole on the top of the wing halves (left and right) for the aileron servo extension exit. Remove the thread out of the hole and secure it in place with adhesive tape.

2-Trial fit each part before gluing . Be certain that there are no gaps. If the parts will join, but with a gaps, sand or trim the parts a little at a time until the parts meet exactly with no gaps.

3-Check for the correct dihedral angle

4-When joining the wing halves it is extremely important to use plenty of epoxy (30 minutes epoxy).

Carefully slide the wing halves together, ensuring that they are accurately aligned, Firmly press the two halves together, allowing the excess epoxy run out. Clean off the excess epoxy

IMPORTANT: Please do not clean off the excess epoxy on the wing with strong solvent or pure alcohol, only use kerosene to keep the colour of your model not fade.

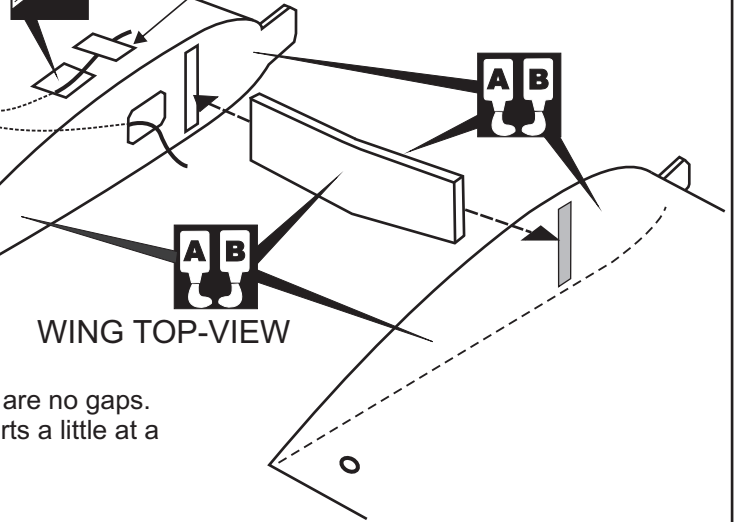

WING TOP-VIEW

2

Included with the radio set.

Cut away the covering of the wing bottom where the aileron servo goes.
Install the servo extension cord in to the wing.
Install the aileron servo on the servo mount.

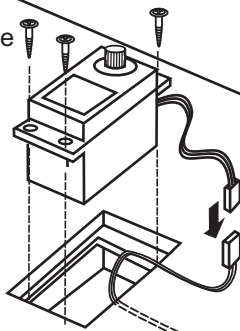

WING BOTTOM-VIEW



Extension cord

3

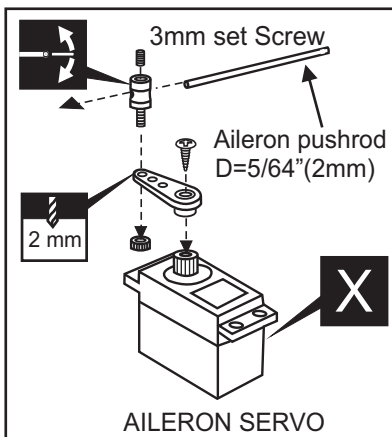

AILERON SERVO

WING BOTTOM-VIEW



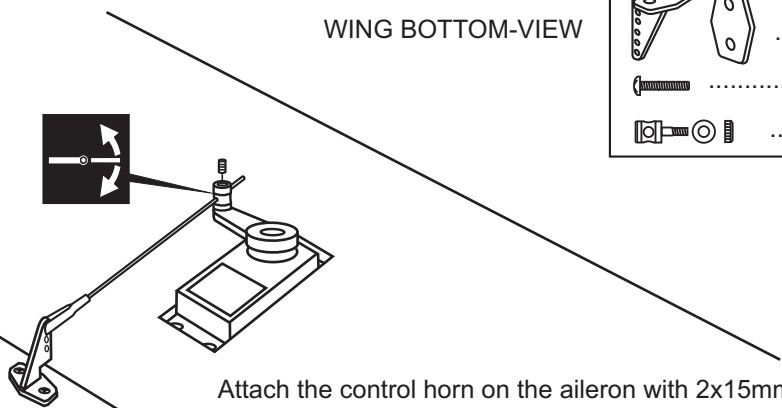

Plastic control horn	
2
4
2



Attach the control horn on the aileron with 2x15mm screws. Screw the clevis halfway on the threaded end of the aileron push rod. Attach the push rod to the aileron horn. Mark the position where the push rod will attach to the servo arm. Cut off the excess length of the push rod

Ensure that the servo is centered. If necessary, adjust the metal clevis so the aileron is also in the neutral position.

4

4		2x3mm	8
	3x10mm	4	
2			

All holes for landing gear installation are pre-drilled at factory.

4A

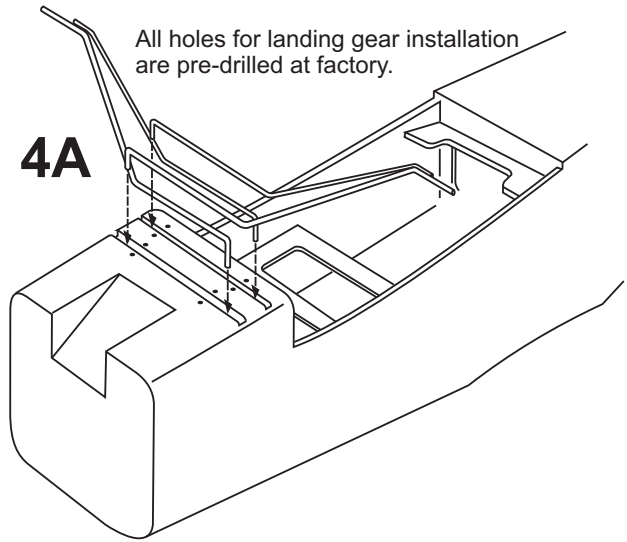

4B

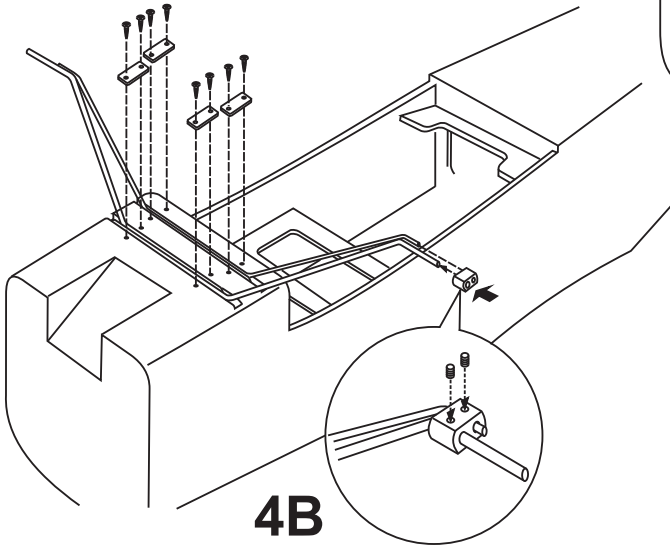

4C

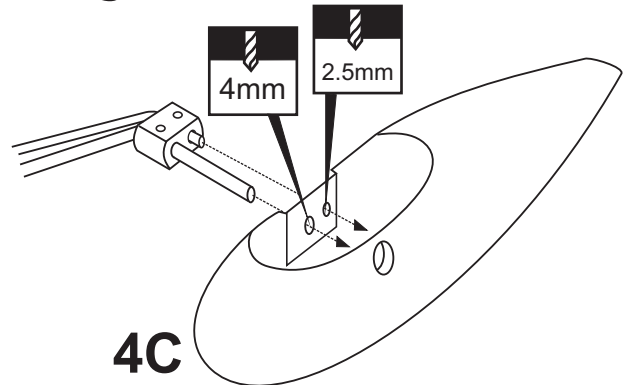

4D

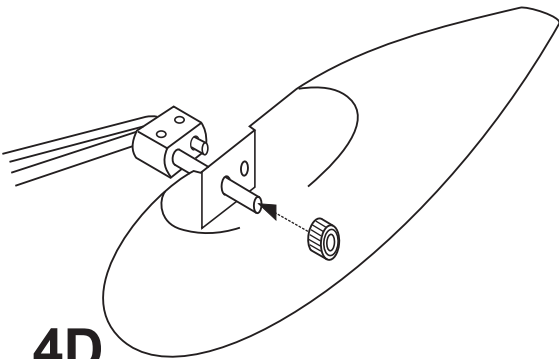

4E

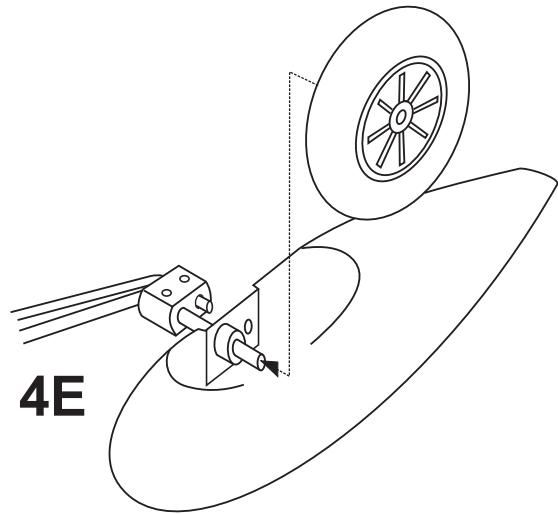

4F

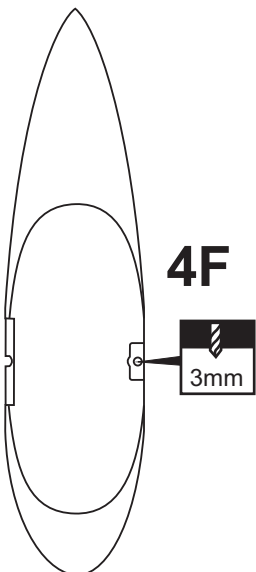

4G

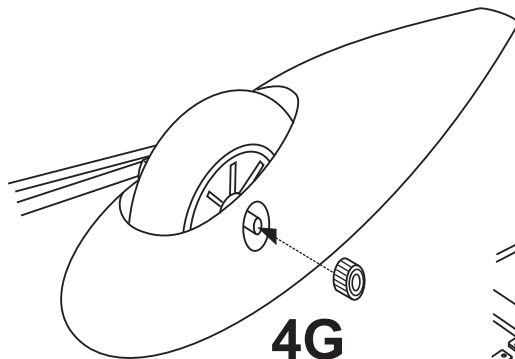

4H

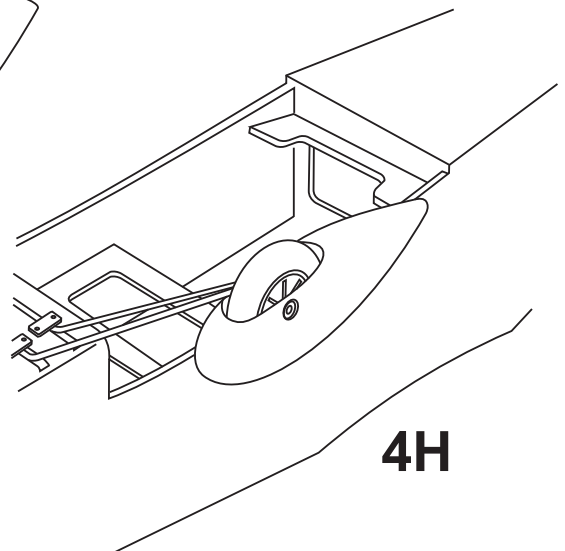

Wheel pant
BOTTOM VIEW

5

5A Full the elevator out of the horizontal stabilizer.

Cut away only the film both side

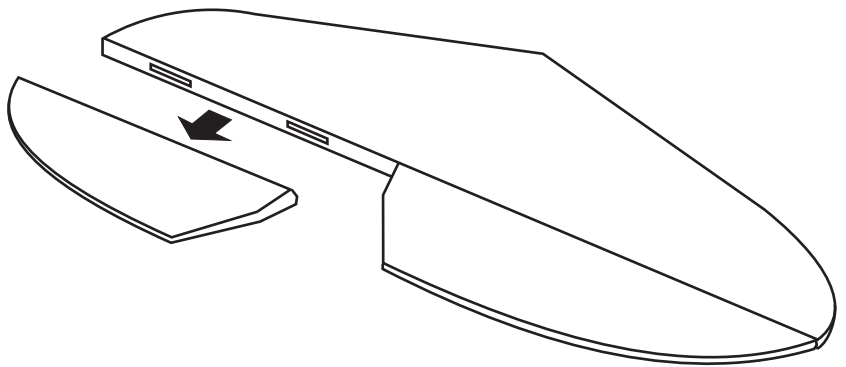

5B

Trial fit the horizontal stabilizer in place. Check the alignment of the horizontal stabilizer.

If the parts will join, but with a gaps, sand or trim the parts a little at a time until the parts meet exactly with no gaps.

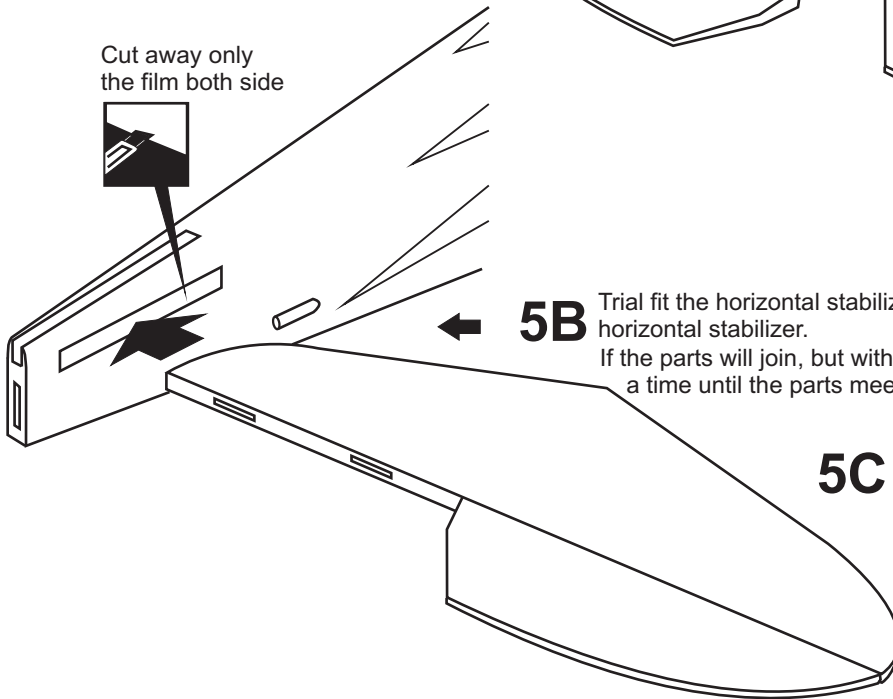

5C

When you are satisfied with the alignment, use a pencil to trace around the top and bottom of the stabilizer where it meets the fuselage.

Cut away only the film both side

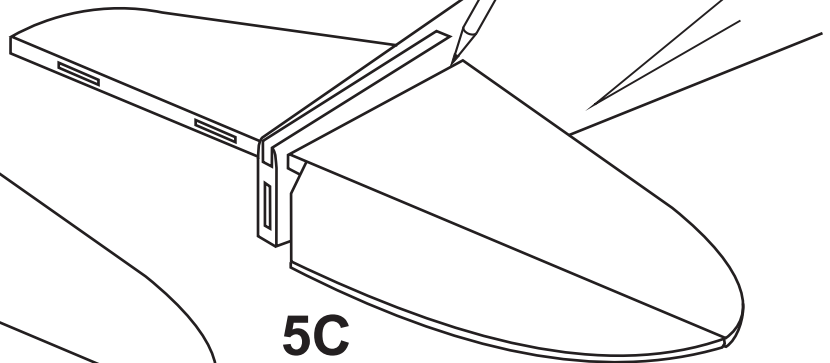

5C

5D

Remove the horizontal stabilizer from the fuselage. Using the sharp hobby knife, carefully cut away the covering inside the lines which were marked above.

*** WARNING: When removing any covering from the airframe, please ensure that you secure the cut edge with CA or similar cement. This will ensure the covering remain tight.**

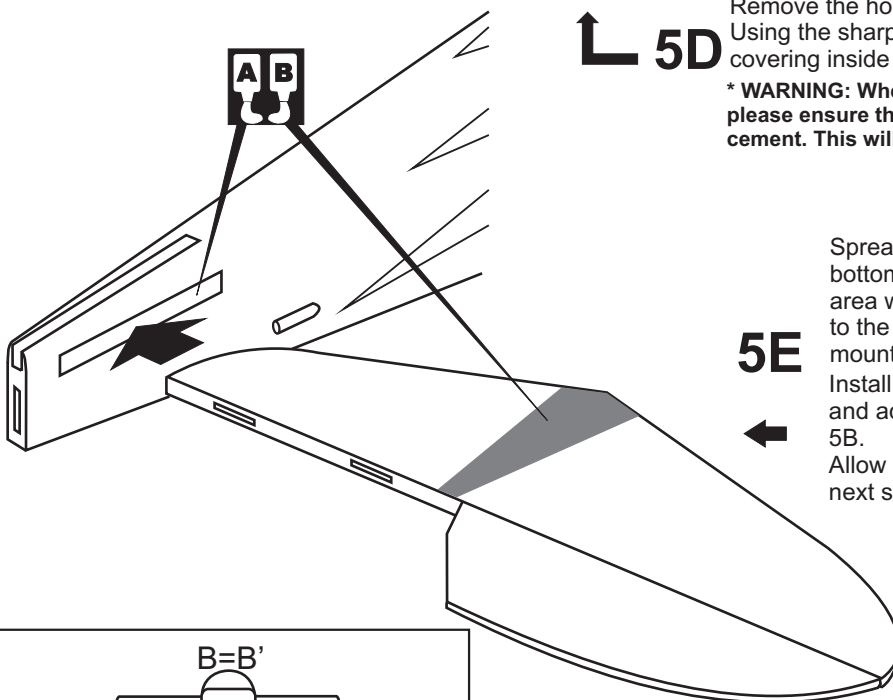

5E

Spread epoxy (30 minute) onto the top and bottom of the horizontal stabilizer along the area where the covering was removed and to the fuselage where the horizontal stabilizer mounts.

Install the horizontal stabilizer into the fuselage and adjust the alignment as described in step 5B.

Allow the epoxy to cure before proceeding to next step.

! Securely glue together If coming off during fly, you lose control of your air plane.

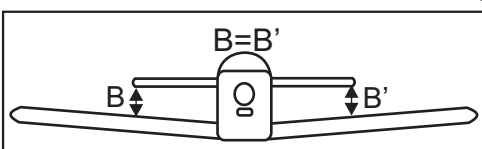

Do the same way with the vertical stabilizer.

6

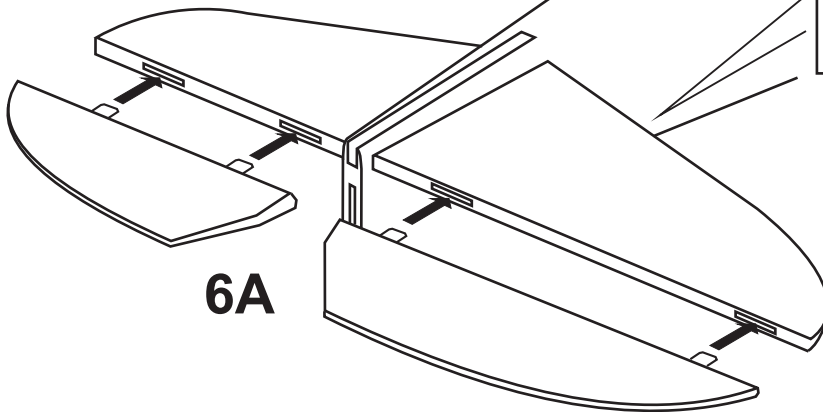

6A

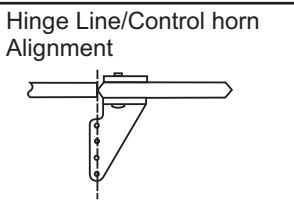
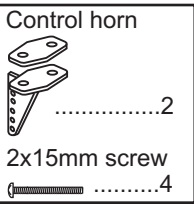
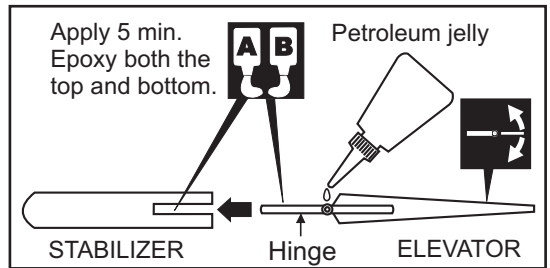

6B Attach the control horn on the elevator.

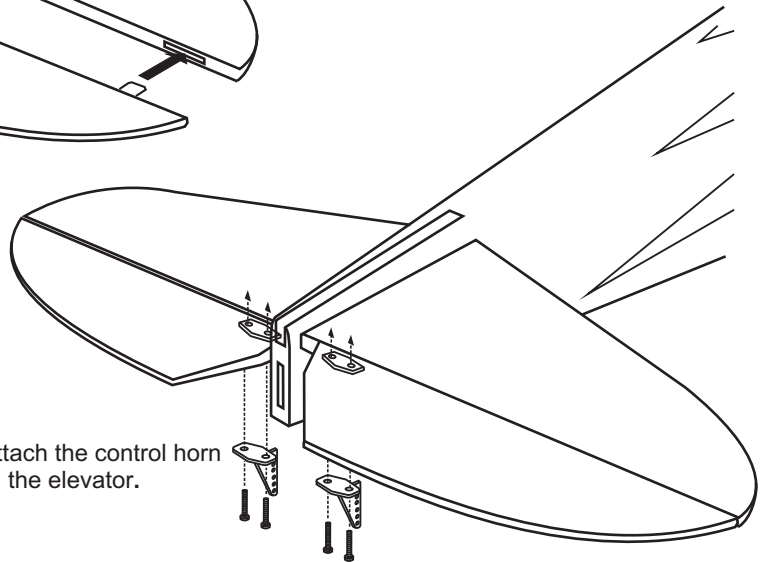

7

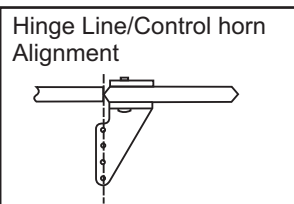
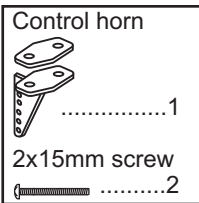

*** WARNING:** When removing any covering from the airframe, please ensure that you secure the cut edge with CA or similar cement. This will ensure the covering remain tight.

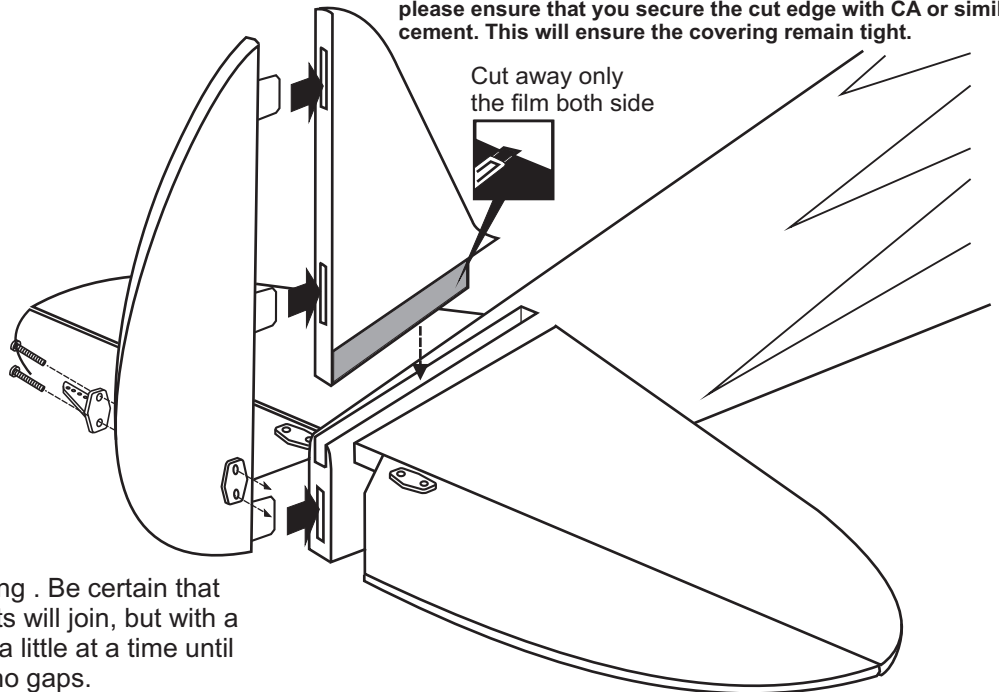

Trial fit each part before gluing . Be certain that there are no gaps. If the parts will join, but with a gaps, sand or trim the parts a little at a time until the parts meet exactly with no gaps.

When joining the stabilizer it is extremely important to use plenty of epoxy (30 min.)or CA glue (thin type)

Carefully slide the stabilizer into the fuselage, ensuring that they are accurately aligned,

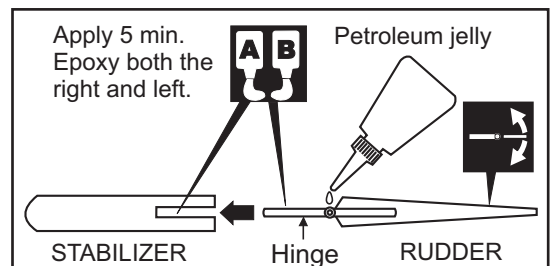
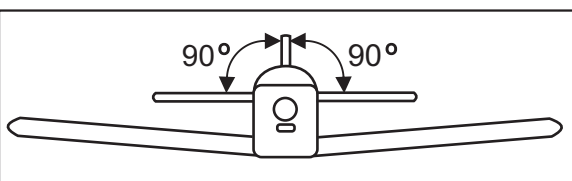

8

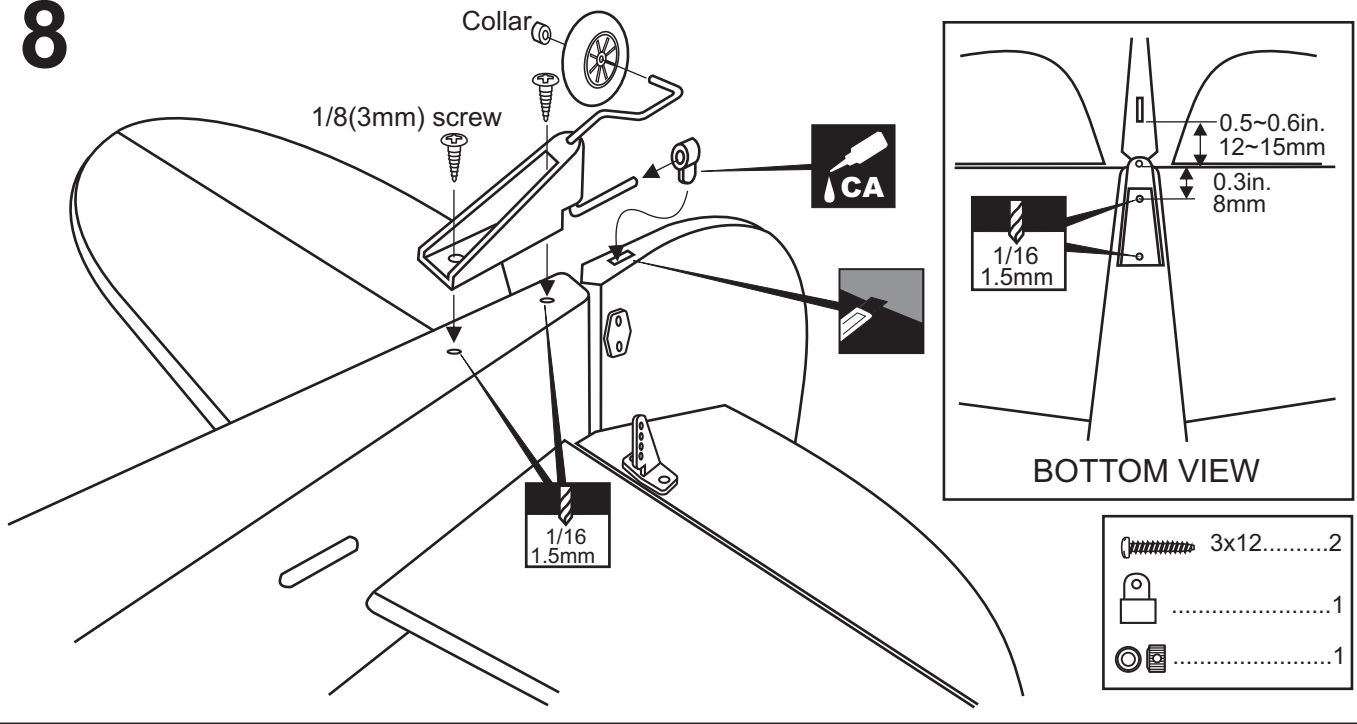

9

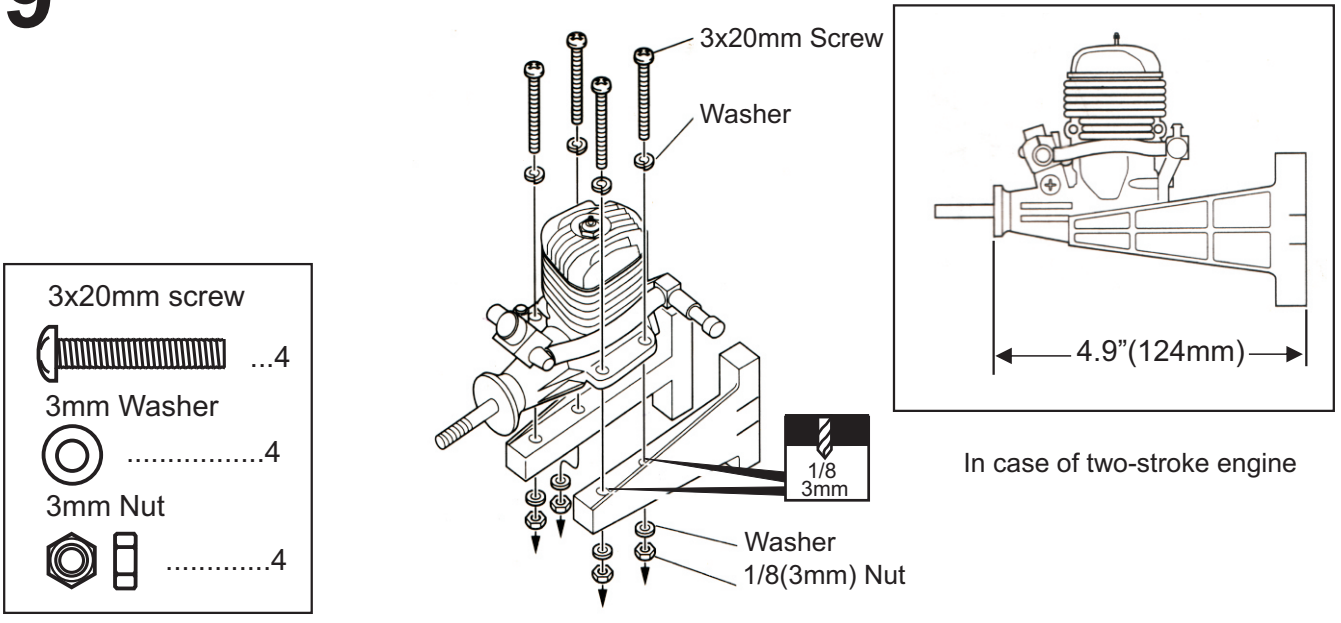

10

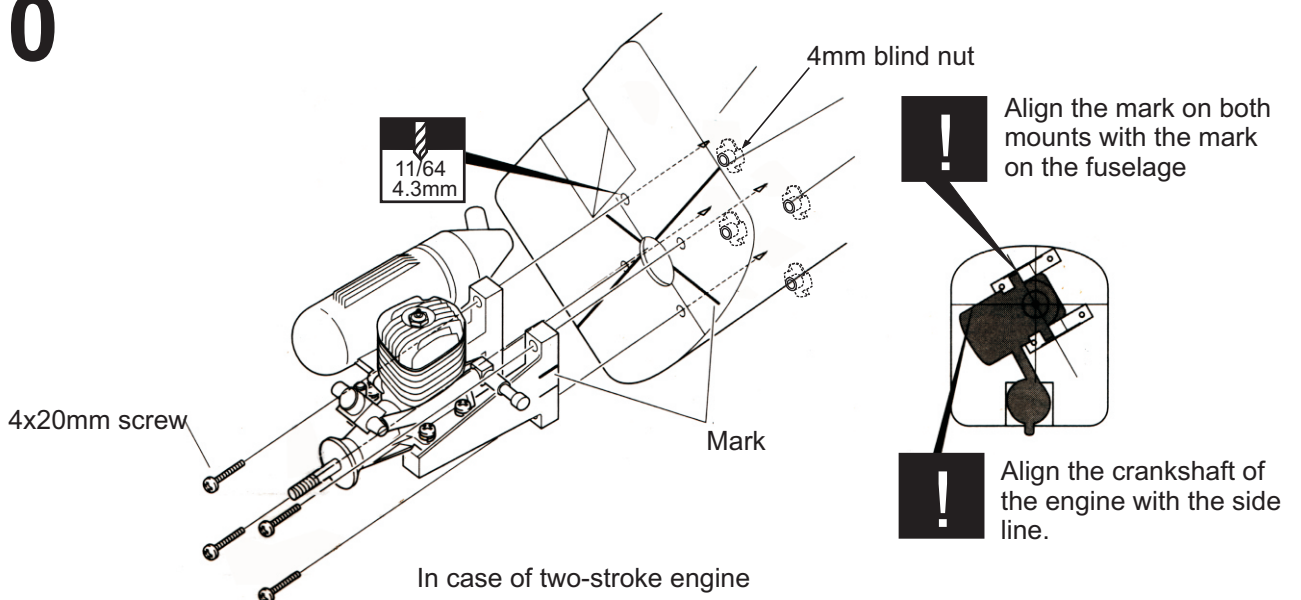

11

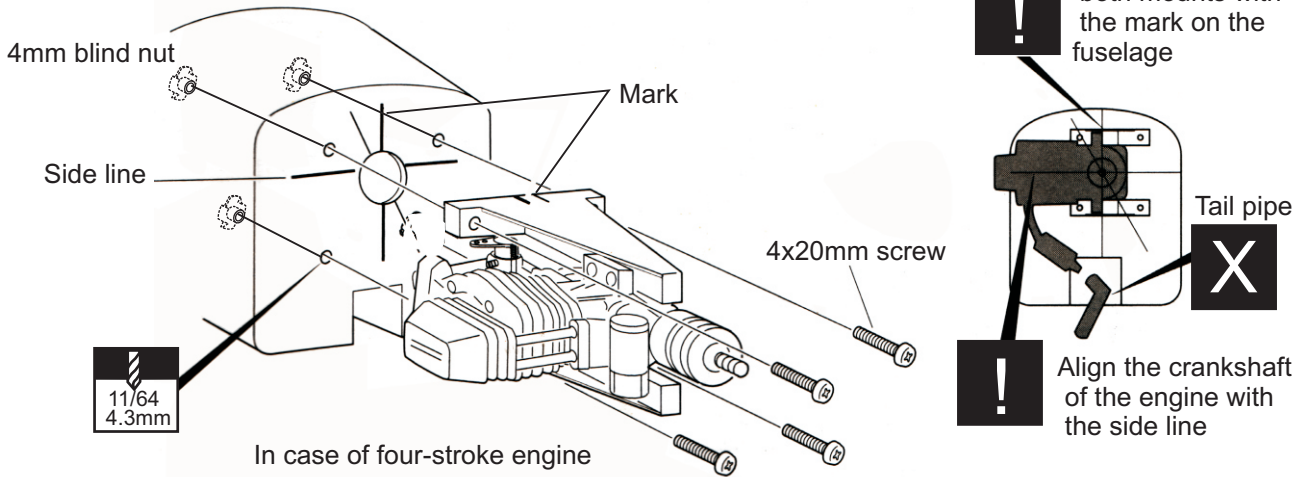

12

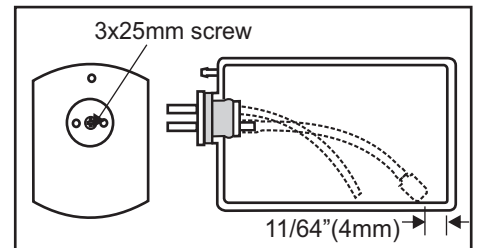
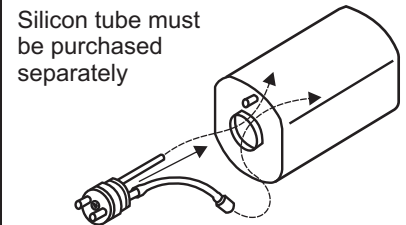
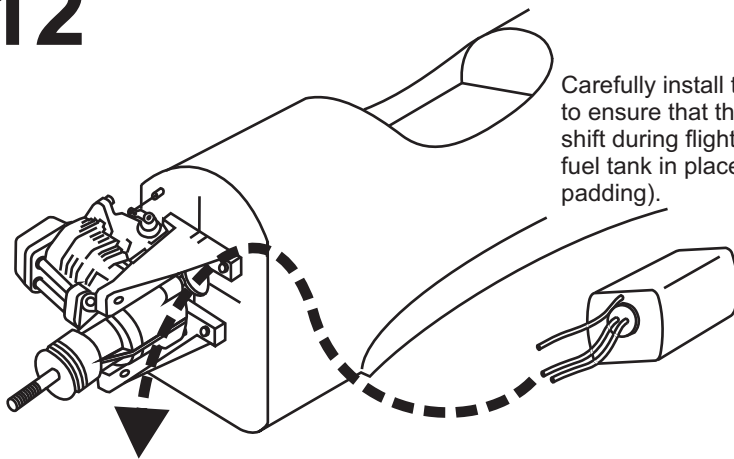

After confirming the direction. Insert this assembly, clunk end first, into the fuel tank and tighten and screw the fuel tank cap on firmly. Ensure that the fuel tank clunk does not touch the rear of the fuel tank.

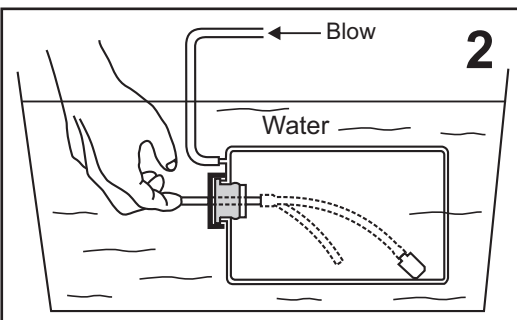

Checking for leaks - block the vents and blow into the feed - if in doubt submersing the tank in a blow of water will show up any problems.

13

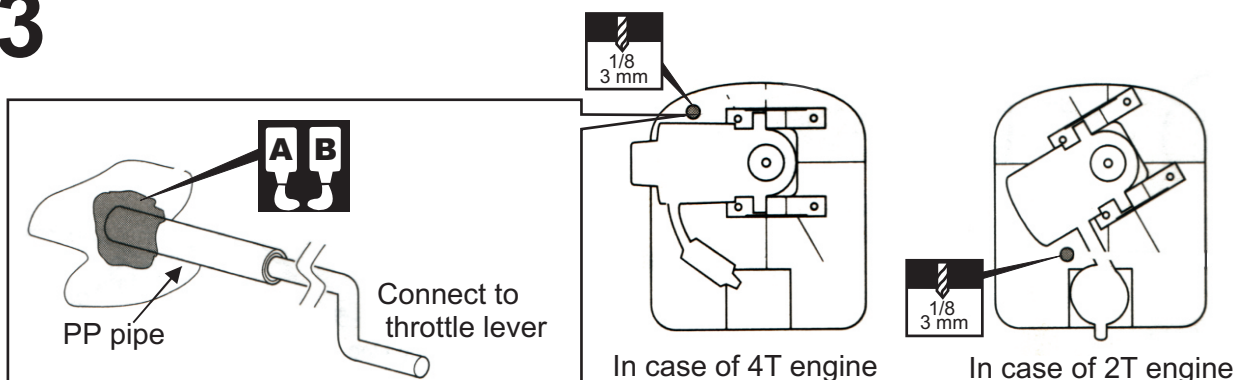

14 BRUSHLESS MOTOR

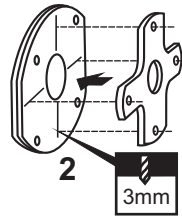
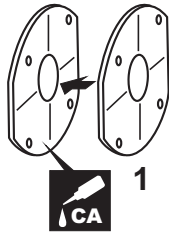

Using an aluminum motor mounting plate as a template, mark the plywood motor mounting plate where the four holes are to be drilled (2).

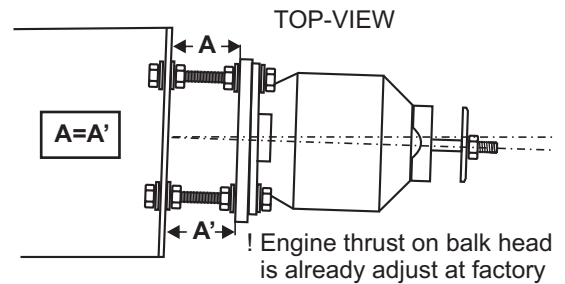
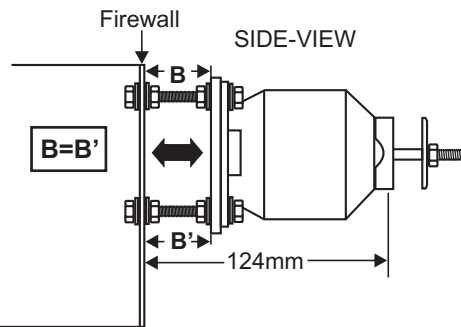
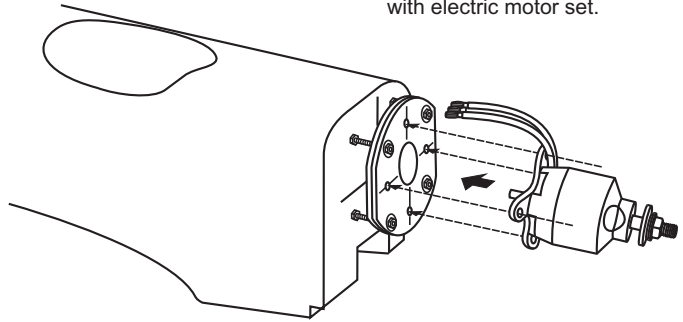
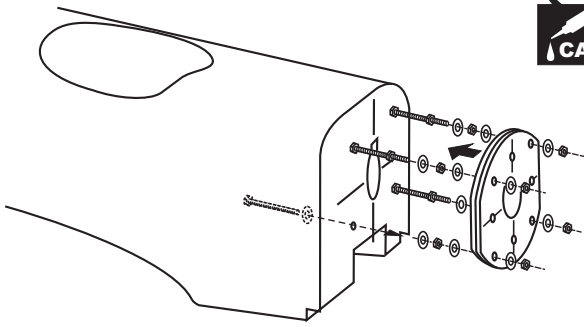

Remove the aluminum motor mounting plate and drill a 1/8" (3mm) hole through the plywood at each of the four marks marked.

Note: The aluminum motor mounting included with electric motor set.

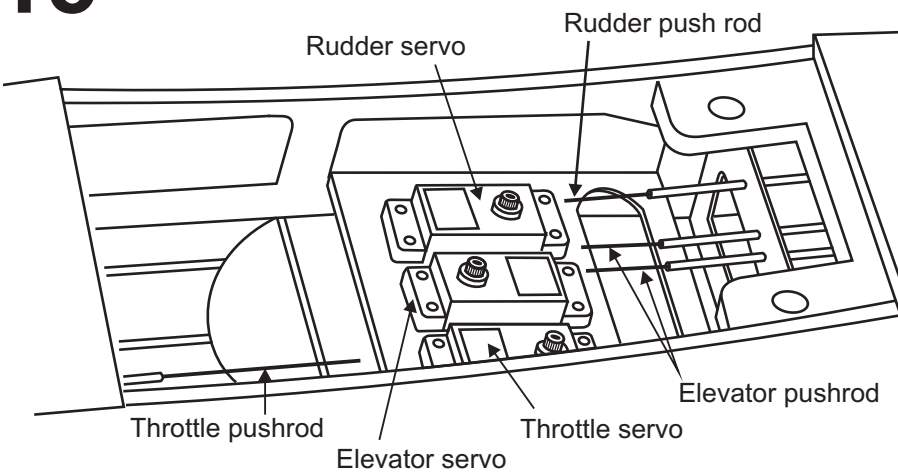

15



- Connector  3
- Connector  1

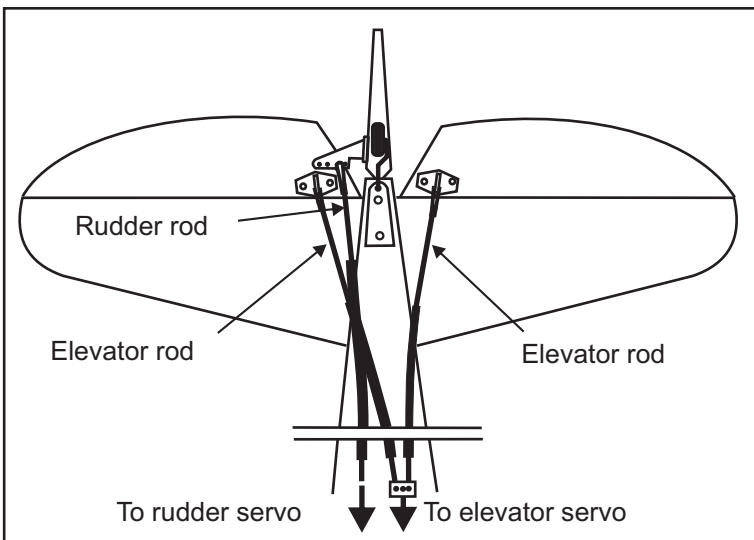
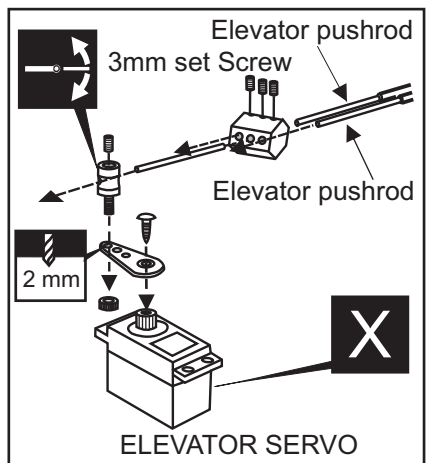
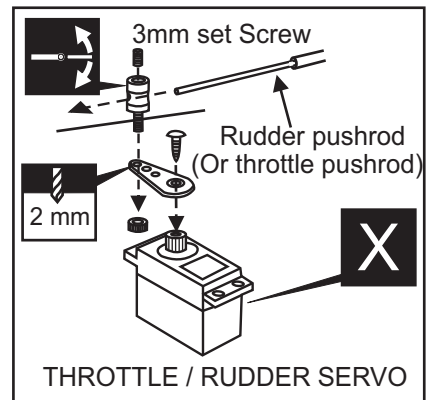



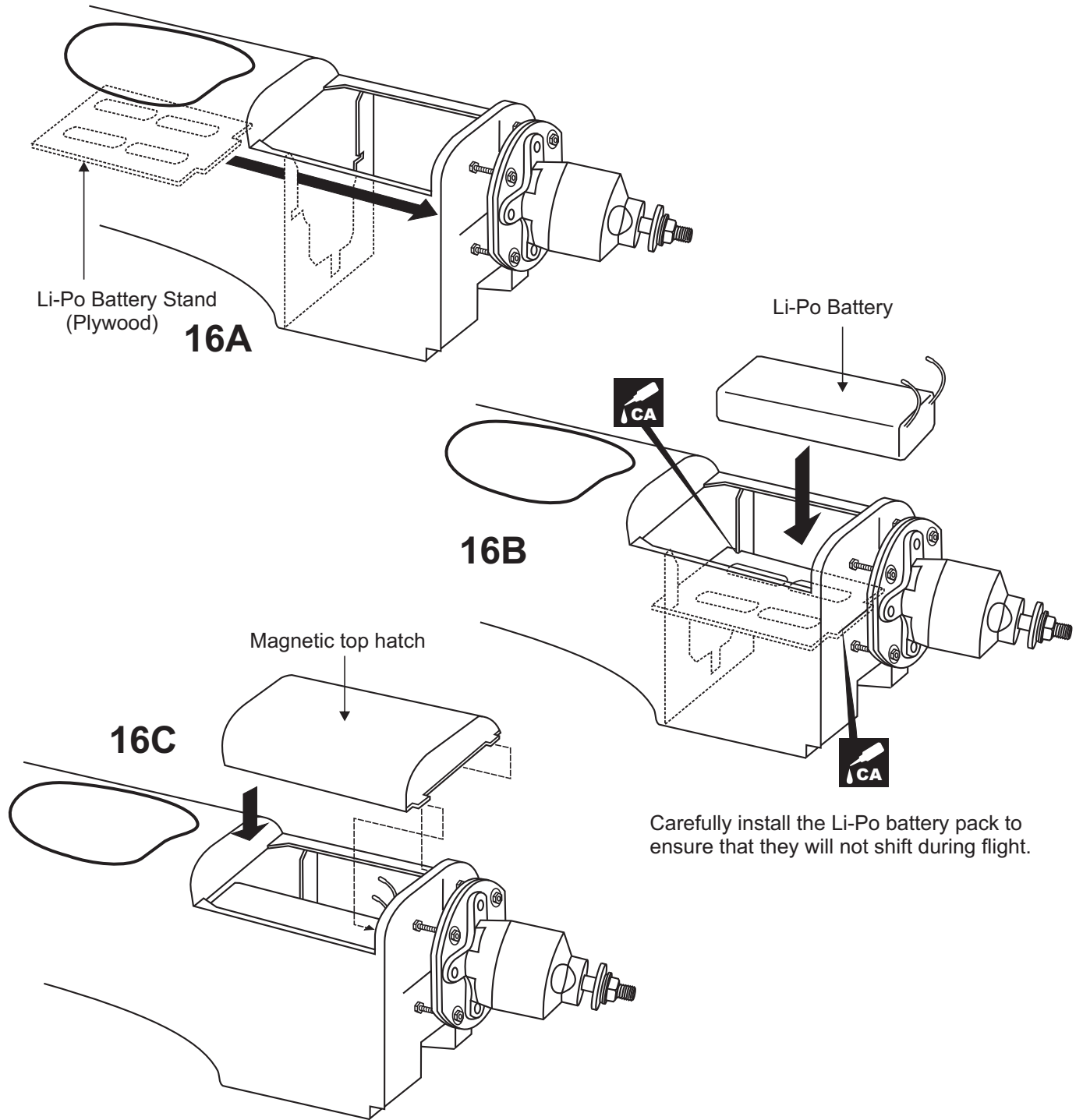

16

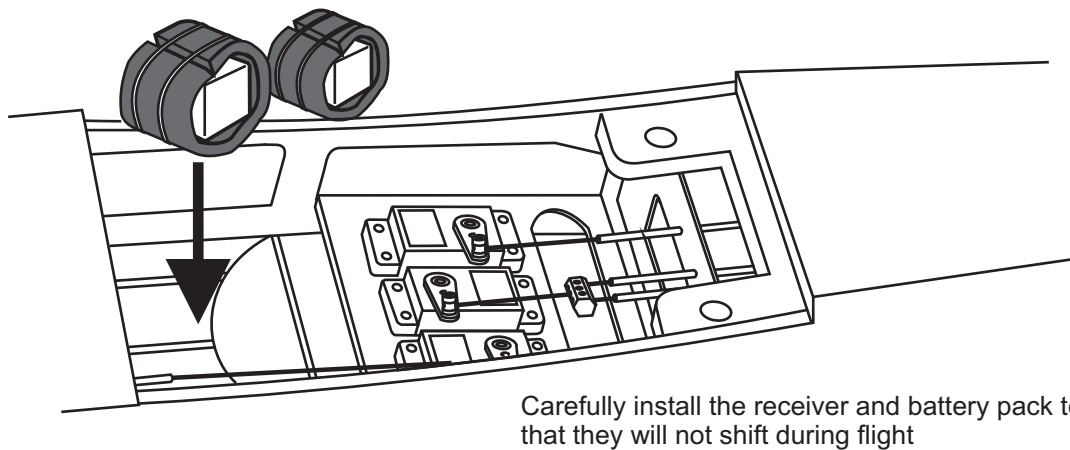

17



18

8
	3 x10mm16
	2.5x10mm4
	2 x5mm4

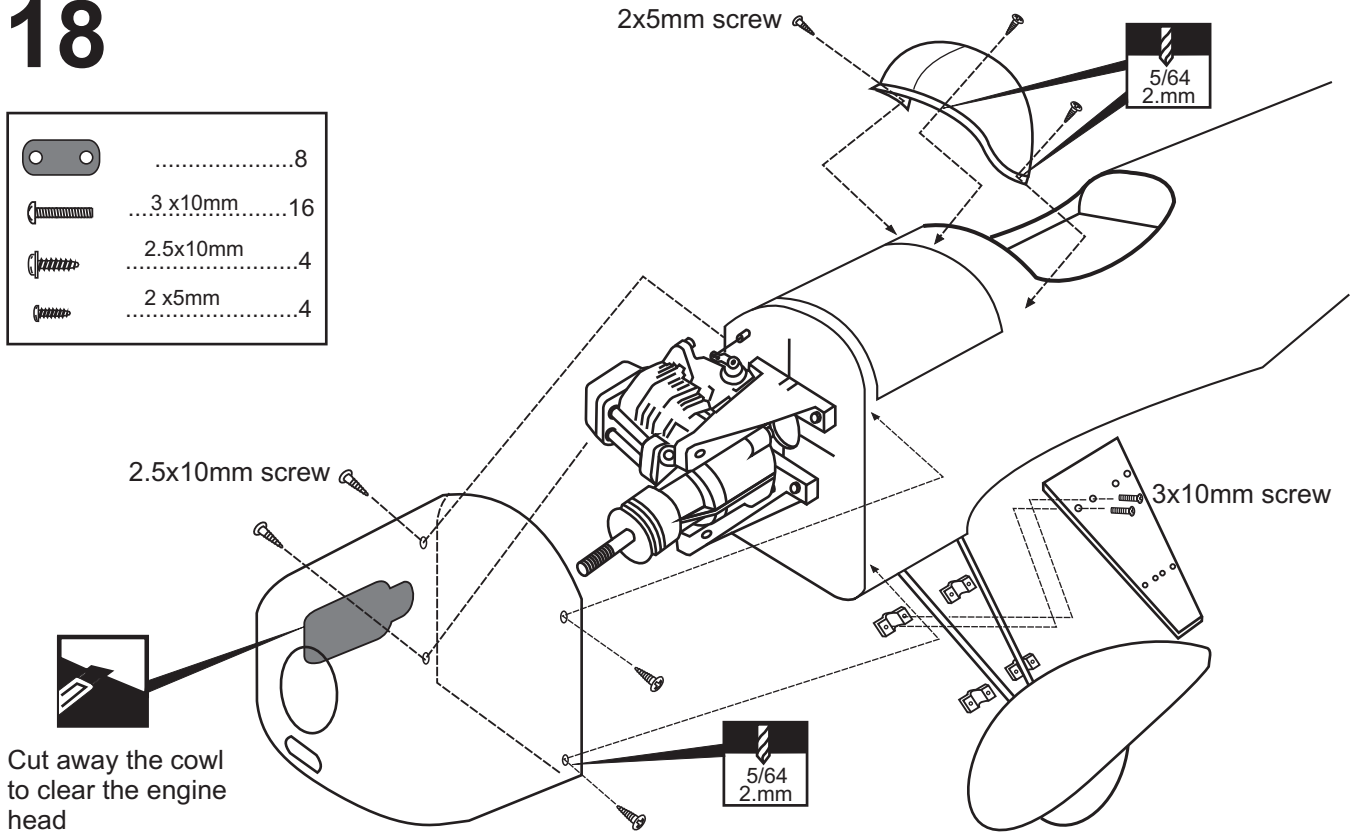

19 Control surface

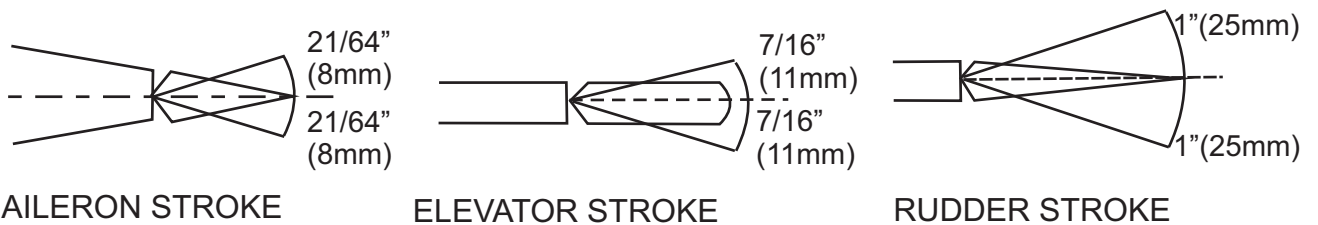

20 Balance

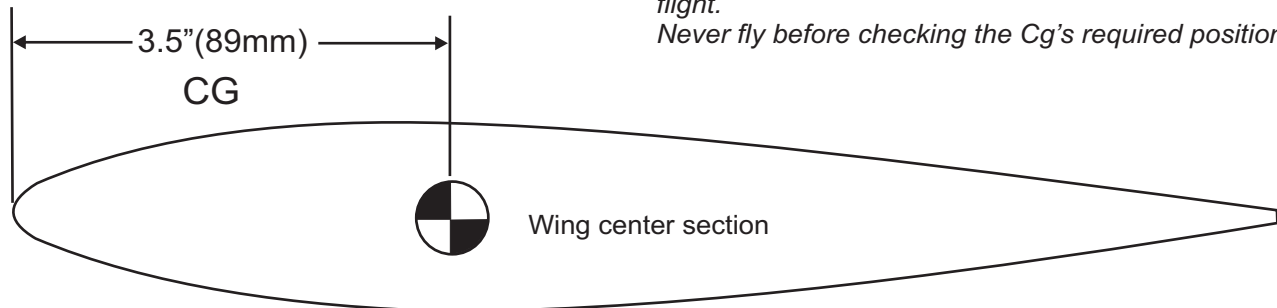

WARNING! Securely install the receiver and power pack, ensuring they will not come loose or rattle during flight. Never fly before checking the Cg's required position.

In order to obtain the CG specified, reposition the receiver and power pack

BEFORE FLYING CHECK EVERYTHING

Before each flight, inspect the airplane for any loose parts. Check the hinges, make sure the pushrods are still firmly attached, and check the engine mounting bolts. In general, check everything on the plane that might possibly come loose.

CHECK THE FREQUENCY BEFORE FLYING

DO NOT FLY NEAR A POWER LINE

The power lines cause radio interference, so avoid flying near them.

Check the operation and direction of the elevator, rudder, ailerons and throttle:

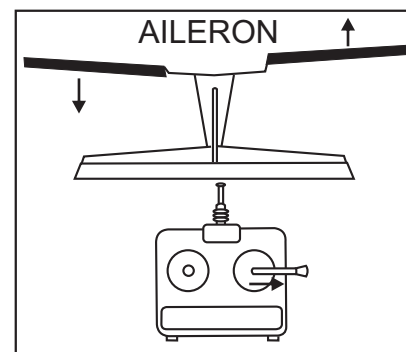
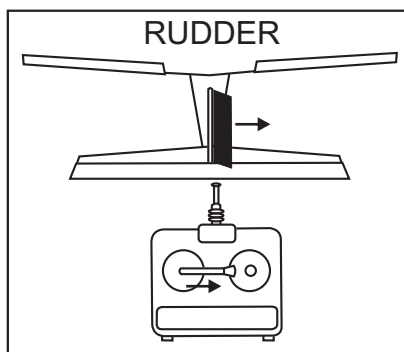
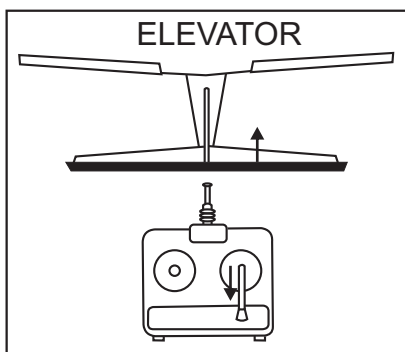

CAUTIONS FOR SAFETY

Ensure the airfield is spacious enough.

Ensure the spinner and propeller are securely attached. Immediately disuse defective propeller as well as deformed spinners.

Adjust the engine always from behind, but never from in front or the sides as rotating propeller may badly injure you.

Do not allow watching people to get too close to a rotating propeller.

Fully extend the transmitter and receiver antenna.

Always take off and landing your airplane into the wind.

Switch off the transmitter and receiver after landing.

Do not fly your airplane above people standing around.

WARNING

Do not put in a large-than recommended engine. A bigger engine does not necessarily mean better performance.

IMPORTANT: Please do not clean your model with pure alcohol, only use liquid soap with water or use glass-cleaner to clean on surface of your model to keep the colour not fade.