

RTR
READY-TO-RUN

AVC US Pat. No. 9,320,977
US Pat. No. 10,528,060



LASERNUT TENACITY ULTRA 4 ROCK RACER

1/10th Scale 4WD RTR

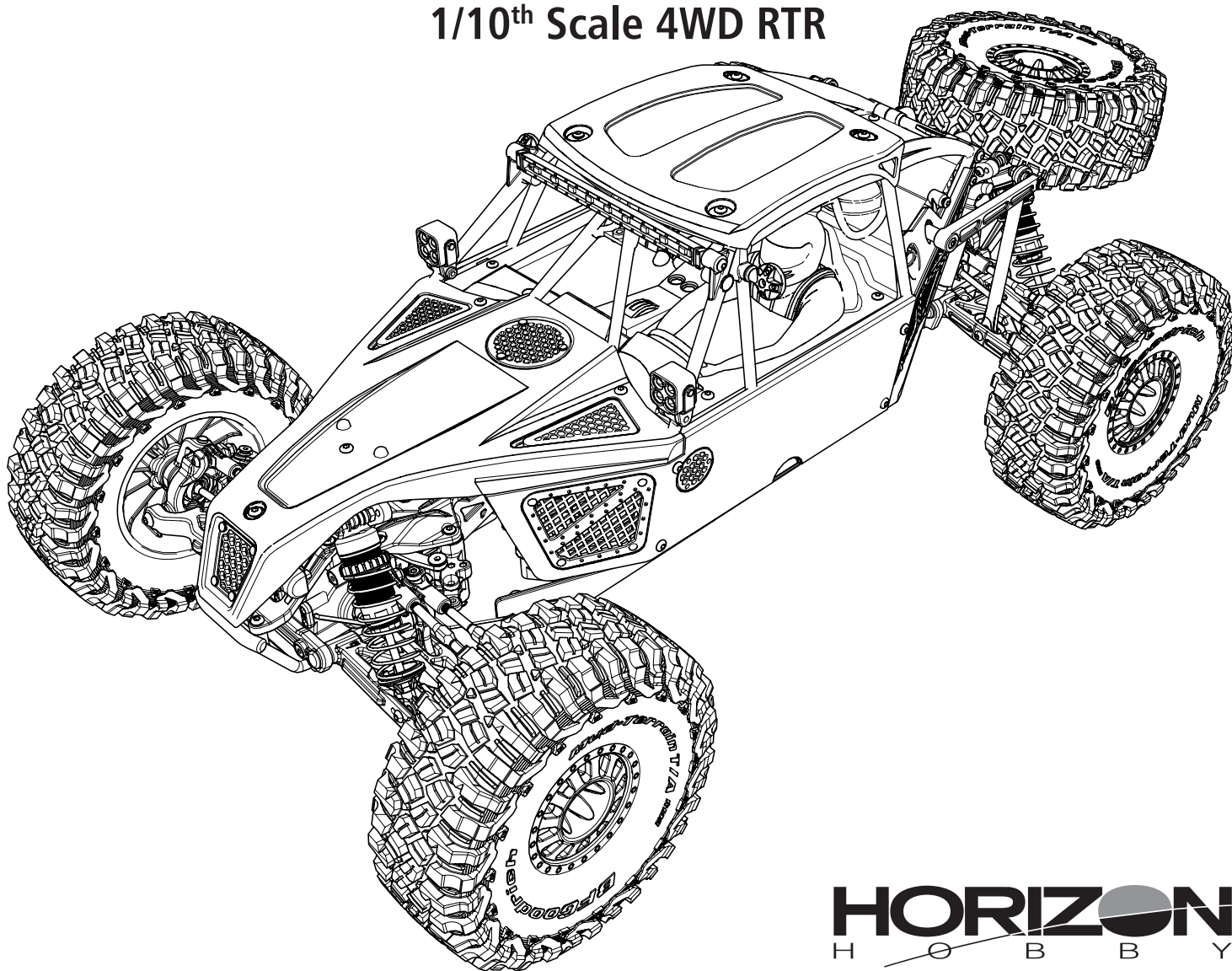

HORIZON
H O B B Y

**INSTRUCTION MANUAL
BEDIENUNGSANLEITUNG
MANUEL D'UTILISATION
MANUALE DI ISTRUZIONI**



Before operating this vehicle, please read all printed materials thoroughly.
Horizon Hobby is not responsible for inadvertent errors in this manual.

NOTICE

All instructions, warranties and other collateral documents are subject to change at the sole discretion of Horizon Hobby, LLC. For up-to-date product literature, visit www.horizonhobby.com or www.towerhobbies.com and click on the support or resources tab for this product.

MEANING OF SPECIAL LANGUAGE

The following terms are used throughout the product literature to indicate various levels of potential harm when operating this product:

WARNING: Procedures, which if not properly followed, create the probability of property damage, collateral damage, and serious injury OR create a high probability of superficial injury.

CAUTION: Procedures, which if not properly followed, create the probability of physical property damage AND a possibility of serious injury.

NOTICE: Procedures, which if not properly followed, create a possibility of physical property damage AND a little or no possibility of injury.

WARNING: Read the ENTIRE instruction manual to become familiar with the features of the product before operating. Failure to operate the product correctly can result in damage to the product, personal property and cause serious injury.

This is a sophisticated hobby product. It must be operated with caution and common sense and requires some basic mechanical ability. Failure to operate this Product in a safe and responsible manner could result in injury or damage to the product or other property. This product is not intended for use by children without direct adult supervision. Do not use with incompatible components or alter this product in any way outside of the instructions provided by Horizon Hobby, LLC. This manual contains instructions for safety, operation and maintenance. It is essential to read and follow all the instructions and warnings in the manual, prior to assembly, setup or use, in order to operate correctly and avoid damage or serious injury.

WARNING AGAINST COUNTERFEIT PRODUCTS Always purchase from a Horizon Hobby, LLC authorized dealer to ensure authentic high-quality Spektrum product. Horizon Hobby, LLC disclaims all support and warranty with regards, but not limited to, compatibility and performance of counterfeit products or products claiming compatibility with DSM or Spektrum technology.

Age Recommendation: Not for children under 14 years. This is not a toy.

SAFETY PRECAUTIONS AND WARNINGS

As the user of this product, you are solely responsible for operating in a manner that does not endanger yourself and others or result in damage to the product or property of others.

This model is controlled by a radio signal subject to interference from many sources outside your control. This interference can cause momentary loss of control, so it is advisable to always keep a safe distance in all directions around your model as this margin will help avoid collisions or injury.

- Never operate your model with low transmitter batteries.
- Always operate your model in open spaces away from full-size vehicles, traffic and people.
- Never operate the model in the street or in populated areas for any reason.
- Carefully follow the directions and warnings for this and any optional support equipment (chargers, rechargeable battery packs, etc.) you use.
- Keep all chemicals, small parts and anything electrical out of the reach of children.

- Never lick or place any portion of the model in your mouth as it could cause serious injury or even death.
- Exercise caution when using tools and sharp instruments.
- Take care during maintenance as some parts may have sharp edges.
- Immediately after using your model, do NOT touch equipment such as the motor, electronic speed control and battery, because they generate high temperatures. You may burn yourself seriously touching them.
- Do not put fingers or any objects inside rotating and moving parts, as this may cause damage or serious injury.
- Always turn on your transmitter before you turn on the receiver in the car. Always turn off the receiver before turning your transmitter off.
- Keep the wheels of the model off the ground when checking the operation of the radio equipment.

TABLE OF CONTENTS

BOX CONTENTS	3	SPECIFICATIONS	6
COMPONENTS.....	3	ESC LED STATUS	6
SPEKTRUM SMART TECHNOLOGY	3	AUDIBLE WARNING TONES	6
WATER-RESISTANT VEHICLE WITH WATERPROOF ELECTRONICS	3	ESC CALIBRATION PROCEDURE	6
GENERAL PRECAUTIONS.....	3	ESC FUNCTIONS AND MODES.....	7
WET CONDITIONS MAINTENANCE	3	PROGRAMMING TABLE	7
QUICK START	3	ESC PROGRAMMING PROCEDURE.....	7
CHARGING THE BATTERY	3	DESCRIPTIONS.....	7
INSTALLING THE BATTERY	4	SPEKTRUM™ FIRMA™ 1900KV BRUSHLESS MOTOR	8
TRANSMITTER FUNCTIONS	4	PRECAUTIONS	8
TRANSMITTER BATTERY INSTALLATION.....	4	GEARING	8
SR6100AT AVC TECHNOLOGY TELEMETRY RECEIVER AUX CHANNELS.....	5	CHANGING THE PINION GEAR/GEAR RATIO	8
BINDING AND CALIBRATING THE RECEIVER	5	SETTING THE GEAR MESH.....	8
DISABLING AVC® TECHNOLOGY STABILITY ASSIST.....	5	TELEMETRY SETTINGS.....	8
FAILSAFE	5	TROUBLESHOOTING GUIDE	8
DRIVING PRECAUTIONS	5	LIMITED WARRANTY	8
POWERING ON THE VEHICLE	5	WARRANTY AND SERVICE CONTACT INFORMATION	9
BEFORE RUNNING THE VEHICLE	5	FCC INFORMATION	9
AVC® SENSITIVITY	5	IC INFORMATION	9
RUN TIME	6	COMPLIANCE INFORMATION FOR THE EUROPEAN UNION	9
TO IMPROVE RUN TIMES.....	6	REPLACEMENT PARTS	34–35
PERFORMING A CONTROL DIRECTION TEST	6	RECOMMENDED PARTS	36
CHANGING THE TRAVEL ADJUST SETTINGS	6	OPTIONAL PARTS	36
SPEKTRUM™ FIRMA™ SMART 130A BRUSHLESS ESC (SPMXSE1130)	6	EXPLODED VIEW	37–41

BOX CONTENTS

COMPONENTS

- Losi® Tenacity® Lasernut Ultra 4 1/10-Scale 4WD RTR Rock Racer
- Spektrum™ DX3™ SMART Transmitter (SPMR2340)
- Spektrum SR6100AT 6 Channel AVC Telemetry Surface Receiver (SPMSR6100AT)
- Spektrum 15KG 23T Waterproof Metal Center Case Servo (SPMS614)
- Spektrum Firma™ SMART 130A Brushless ESC (SPMXSE1130)
- 3668 - 1900Kv BL 4 Pole Motor (SPMXSM2200)
- 4 AA batteries (for transmitter)

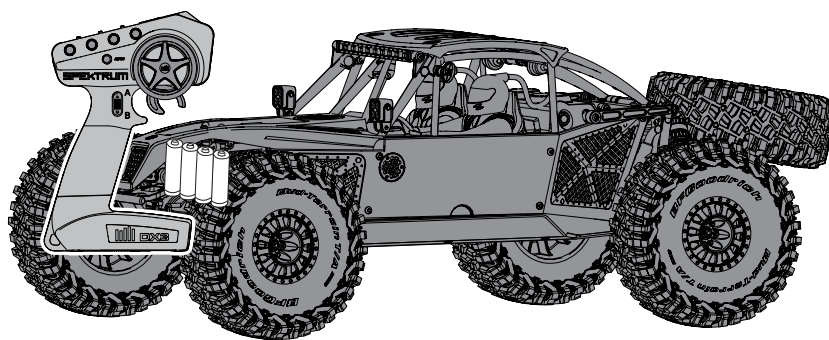

SPEKTRUM SMART TECHNOLOGY

The Lasernut Ultra 4 includes Spektrum SMART Technology in the ESC and receiver, which can provide you with telemetry information including battery voltage and vehicle temperature. To take advantage of SMART Technology, you'll need a SMART compatible transmitter. The included DX3 Active transmitter can be upgraded with the Spektrum Bluetooth Module (SPM6741) Or, consider upgrading to a SMART Technology compatible Spektrum transmitter

like the DX5C (SPMR5100—transmitter only), DX5 Pro (SPMR5010—transmitter only), or DX5 Rugged (SPM5200—includes SR515 receiver). Use Spektrum SMART batteries to power your vehicle to take full advantage of SMART Technology, which can communicate battery data through the SMART system as well.

Visit www.SpektrumRC.com for more information.

WATER-RESISTANT VEHICLE WITH WATERPROOF ELECTRONICS

Your new Horizon Hobby vehicle has been designed and built with a combination of waterproof and water-resistant components to allow you to operate the product in many "wet conditions," including puddles, creeks, wet grass, snow and even rain.

While the entire vehicle is highly water-resistant, it is not completely waterproof and your vehicle should NOT be treated like a submarine. The various electronic components used in the vehicle, such as the Electronic Speed Control (ESC), servo(s) and receiver are waterproof, however, most of the mechanical components are water-resistant and should not be submerged.

Metal parts, including the bearings, hinge pins, screws and nuts, as well as the contacts in the electrical cables, will be susceptible to corrosion if additional maintenance is not performed after running in wet conditions. To maximize the long-term performance of your vehicle and to keep the warranty intact, the procedures described in the "Wet Conditions Maintenance" section below must be performed regularly if you choose to run in wet conditions. If you are not willing to perform the additional care and maintenance required, then you should not operate the vehicle in those conditions.

CAUTION: Failure to exercise caution while using this product and complying with the following precautions could result in product malfunction and/or void the warranty.

GENERAL PRECAUTIONS

- Read through the wet conditions maintenance procedures and make sure that you have all the tools you will need to properly maintain your vehicle.
- Not all batteries can be used in wet conditions. Consult the battery manufacturer before use. Caution should be taken when using Li-Po batteries in wet conditions.
- Most transmitters are not water-resistant. Consult your transmitter's manual or the manufacturer before operation.
- Never operate your transmitter or vehicle where lightning may be present.
- Do not operate your vehicle where it could come in contact with salt water (ocean water or water on salt-covered roads), contaminated or polluted water. Salt water is very conductive and highly corrosive, so use caution.
- Even minimal water contact can reduce the life of your motor if it has not been certified as water-resistant or waterproof. If the motor becomes excessively wet, apply very light throttle until the water is mostly removed from the motor. Running a wet motor at high speeds may rapidly damage the motor.

- Driving in wet conditions can reduce the life of the motor. The additional resistance of operating in water causes excess strain. Alter the gear ratio by using a smaller pinion or larger spur gear. This will increase torque (and motor life) when running in mud, deeper puddles, or any wet conditions that will increase the load on the motor for an extended period of time.

WET CONDITIONS MAINTENANCE

- Drain any water that has collected in the tires by spinning them at high speed. With the body removed, place the vehicle upside down and pull full throttle for a few short bursts until the water has been removed.

CAUTION: Always keep hands, fingers, tools and any loose or hanging objects away from rotating parts when performing the above drying technique.

- Remove the battery pack(s) and dry the contacts. If you have an air compressor or a can of compressed air, blow out any water that may be inside the recessed connector housing.
- Remove the tires/wheels from the vehicle and gently rinse the mud and dirt off with a garden hose. Avoid rinsing the bearings and transmission.

NOTICE: Never use a pressure washer to clean your vehicle.

- Use an air compressor or a can of compressed air to dry the vehicle and help remove any water that may have gotten into small crevices or corners.
- Spray the bearings, drive train, fasteners and other metal parts with a water-displacing light oil. Do not spray the motor.
- Let the vehicle air dry before you store it. Water (and oil) may continue to drip for a few hours.
- Increase the frequency of disassembly, inspection and lubrication of the following:
 - Front and rear axle hub assembly bearings.
 - All transmission cases, gears and differentials.
 - Motor—clean with an aerosol motor cleaner and re-oil the bushings with lightweight motor oil.

QUICK START

Please read the entire manual to gain a full understanding of the LASERNUT U4 RTR vehicle, fine-tuning the setup and performing maintenance.

1. Read the safety precautions found in this manual.
2. Charge a battery for the vehicle. Refer to the included charging warnings and instructions for battery charging information.
3. Install the AA batteries in the transmitter. Only use alkaline or rechargeable batteries.
4. Install the fully charged battery in the vehicle.
5. Power ON the transmitter and then the vehicle. Wait 5 seconds for the ESC to initialize. Always power the transmitter ON before the vehicle and power it OFF after the vehicle has been powered OFF.
6. Check the steering and throttle control directions. Verify that the servos are moving in the correct direction.
7. Drive your vehicle.
8. Perform any necessary maintenance.

CHARGING THE BATTERY

Choose a battery designed to work with the Spektrum™ Firma™ SMART 130A Brushless ESC (SPMXSE1130). We recommend the Spektrum 5000mAh 3S 11.1V 50C SMART LiPo hardcase battery with IC5® connector (SPMX50003S50H5) or Spektrum 5000mAh 4S 14.8V 50C SMART LiPo IC5 hardcase battery with IC5 connector (SPMC50004S50H5). Choose a charger designed to charge 3S and/or 4S Li-Po batteries.

We recommend the Spektrum SMART dual-output AC charger, 2x100W (SPMXC1010). Refer to your battery and charger manuals for usage, safety, and charging information.

IMPORTANT: When using a 3S battery, you must change the motor pinion gear to the 14T pinion provided with your vehicle.

INSTALLING THE BATTERY

1. Ensure the ESC is powered OFF.
2. Remove the body clips and rotate the body up.
3. Undo the hook and loop straps.
4. Insert the battery into the battery tray.
5. Secure the hook and loop straps.
6. Connect the battery power lead to the ESC, noting proper polarity.
7. Power ON the transmitter, then the vehicle.
8. Rotate the body into place, and insert the body clips.

IMPORTANT: Secure the ESC wires so they do not interfere with the gearing.

NOTICE: If you are using a 3S Li-Po battery, use the included 14T pinion gear. If you are using a 4S Li-Po battery, use the installed 12T pinion gear. Using a 14T pinion gear with a 4S Li-Po battery will result in damage to the ESC and motor.

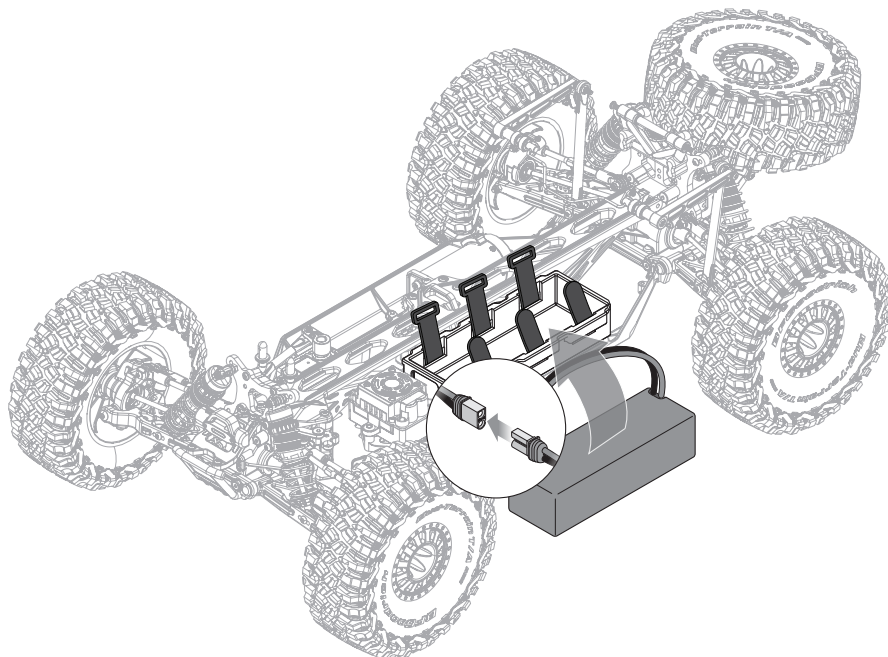

TRANSMITTER FUNCTIONS

A/B. Channel 3 Button

C. Throttle/Brake

D. Steering Wheel

E. Steering Rate

Adjusts the end point of the steering

F. Brake Rate

Adjusts the braking end point.

G. Steering Trim

Adjusts the steering center point. Normally, the steering trim is adjusted until the vehicle tracks straight.

H. Throttle Trim

Adjusts the throttle neutral point

I. SMART Battery Level Indicator

J. Servo Reversing

To reverse the Throttle (TH) or Steering (ST) channel, switch the position of the correlating switch—"N" is for normal, "R" is for reverse.

K. Throttle Limit

Limits throttle output to 50/75/100%

Select 50% or 75% for less experienced drivers or when you are driving the vehicle in a small area.

L. Power LED

- **Solid red lights:** Indicates radio connectivity and adequate battery power
- **Flashing red lights:** Indicates the battery voltage is critically low. Replace batteries

M. Power Button

N. Bind Button

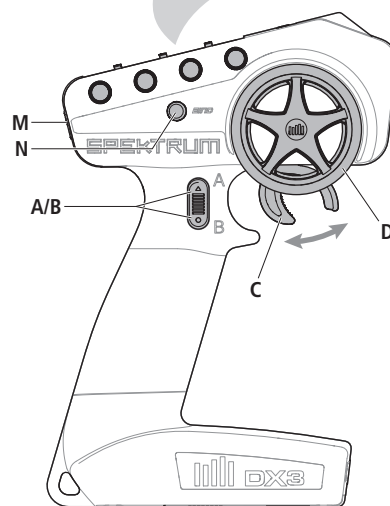
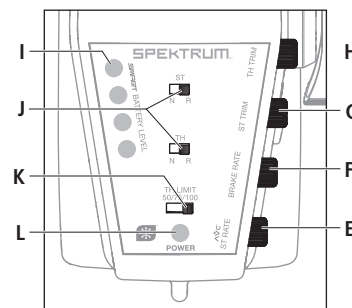

TRANSMITTER BATTERY INSTALLATION

This transmitter requires 4 AA batteries

1. Remove the battery cover from the transmitter.
2. Install the batteries as shown.
3. Install the battery cover.

CAUTION: Never remove the transmitter batteries while the model is powered ON. Loss of model control, damage, or injury may occur.

CAUTION: If using rechargeable batteries, charge only rechargeable batteries. Charging non-rechargeable batteries may cause the batteries to burst, resulting in injury to persons and/or damage to property.

CAUTION: Risk of explosion if battery is replaced by an incorrect type. Dispose of used batteries according to national regulations.

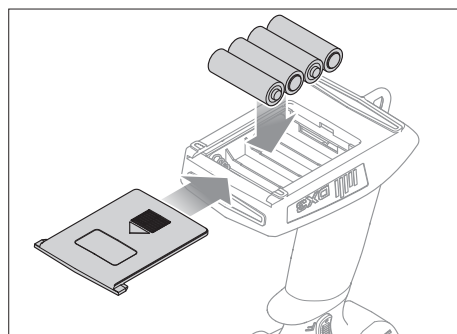

SR6100AT AVC TECHNOLOGY TELEMETRY RECEIVER

AUX CHANNELS

The Aux channels can operate as additional servo channels, or as a power supply for a personal transponder.

If AVC is active, only 4 channels; Steering, Throttle, AUX3 and AUX4 are operational. The remaining Aux channels can be used to power a personal transponder or lights.

If AVC is disabled (see **DISABLING AVC TECHNOLOGY STABILITY ASSIST FUNCTION**), all 6 channels including the Aux channels can operate as servo channels.

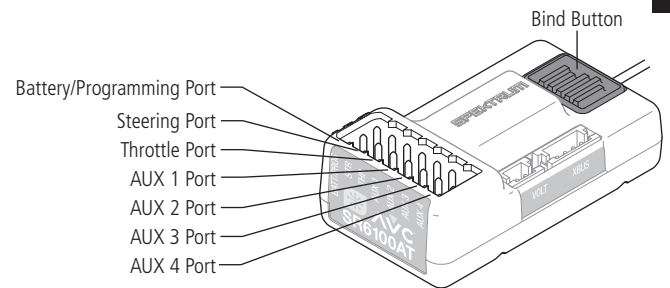

BINDING AND CALIBRATING THE RECEIVER

Binding is the process of linking the SR6100AT receiver to your Spektrum transmitter. The AVC features on the receiver can be enabled or disabled during the binding process.

IMPORTANT: You must calibrate the SR6100AT receiver each time it is placed in bind mode, regardless of AVC being enabled or disabled.

Upon initial setup after the first bind, the model must be configured for servo direction, trim and travel. Then the receiver must be rebound and calibrated to those settings for proper operation. Center the steering trim and throttle trim on the transmitter before beginning.

1. Press and hold the bind button on the receiver.
2. Power on the receiver. The orange LED flashes, indicating the receiver is in bind mode. Release the bind button after the orange LED illuminates.
3. Put your transmitter in bind mode. The bind process is complete when the orange LED on the receiver remains lit. The receiver is now bound to the transmitter but must be calibrated before it will operate.
4. Pull the transmitter trigger to full throttle, pause, then return the trigger to center.
5. Push the transmitter trigger to full brake, pause, then return the trigger to center.

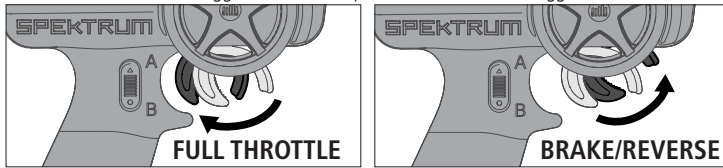

6. Turn the transmitter steering wheel to full right, pause, then return the wheel to center.
7. Turn the transmitter steering wheel to full left, pause, then return the steering wheel to center. The orange LED flashes to confirm the settings have been accepted.
8. Turn off the vehicle to complete the binding and calibration process.

CAUTION: When the bind process is complete, the throttle and steering channels are active. Keep hands and loose objects away from all spinning parts on the vehicle.

IMPORTANT: You must rebind the transmitter and receiver if you:

- Change the servo reversing after binding
- Change the travel after binding
- Change the receiver mounting orientation

DISABLING AVC® TECHNOLOGY STABILITY ASSIST

If you participate in organized racing, you may be required to turn AVC technology off. To turn off AVC technology:

1. Connect power to the receiver and quickly press and release the bind button three times (within 1.5 seconds).
2. Press and hold the bind button and to put the receiver in bind mode. Release the button when the LED starts to flash rapidly, indicating it is in bind mode.

When the AVC system has been disabled, the LED on the receiver will show three flashes upon power up, and then remain lit. The receiver is bound and operating normally when the LED remains illuminated.

TIP: If the AVC feature in the receiver is active and the AVC menu in the transmitter is inhibited, AVC functions will default to the AUX 1 and AUX 2 operation, and in this scenario, AVC will not work correctly.

FAILSAFE

In the unlikely event that the radio link is lost during use, the receiver will drive the throttle channel to the neutral position. If the receiver is powered on prior to turning on the transmitter, the receiver will enter the failsafe mode, driving the throttle channel to the neutral position. When the transmitter is turned on, normal control is resumed.

IMPORTANT: Failsafe activates only in the event that signal is lost from the transmitter. Failsafe will NOT activate in the event that receiver battery power decreases below the recommended minimums or power to the receiver is lost.

DRIVING PRECAUTIONS

- Maintain sight of the vehicle at all times.
- Routinely inspect the vehicle for loose wheel hardware.
- Routinely inspect the steering assembly for any loose hardware. Driving the vehicle off-road can cause fasteners to loosen over time.
- Do not drive the vehicle in tall grass. Doing so can damage the vehicle or electronics.
- Stop driving the vehicle when you notice a lack of power. Driving the vehicle when the battery is discharged can cause the receiver to power off. If the receiver loses power, you will lose control of the vehicle. Damage due to an over-discharged Li-Po battery is not covered under warranty.

CAUTION: Do not discharge a Li-Po battery below 3V per cell. Batteries discharged to a voltage lower than the lowest approved voltage may become damaged, resulting in loss of performance and potential fire when batteries are charged.

- Do not apply forward or reverse throttle if the vehicle is stuck. Applying throttle in this instance can damage the motor or ESC.
- After driving the vehicle, allow the electronics to cool before driving the vehicle again.

IMPORTANT: Keep wires away from all moving parts.

BEFORE RUNNING THE VEHICLE

1. Check for free suspension movement. All suspension arms and steering components should move freely. Any binds will cause the vehicle to handle poorly.

TIP: To increase the ride height and ground clearance of your vehicle, screw down the shock collars to compress the springs.

2. Charge a battery pack. Always charge the battery pack as per the battery and/or charger manufacturers' instructions.
3. Set the transmitter steering trim. Follow the instructions to set the steering trim/subtrim so that the vehicle drives straight with no input to the steering.
4. Perform a Control Direction Test.

POWERING ON THE VEHICLE

1. Center the ST TRIM and TH TRIM dials on the transmitter.
2. Power on the transmitter.
3. Install a fully charged battery pack per the *Installing the Battery* section.
4. Power on the ESC.

IMPORTANT: The vehicle MUST remain on a flat, level surface and motionless for at least 5 seconds.

AVC® SENSITIVITY

The ST RATE dial adjusts the sensitivity, or stability, value in the receiver. If you increase the sensitivity, the AVC® system becomes more sensitive to the vehicle drifting left or right. You would use maximum sensitivity during high speed driving or drag racing, when you want the vehicle to stay in a straight line.

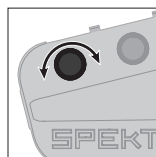

Turn the ST RATE knob counter-clockwise to reduce the sensitivity.

Turn the ST RATE knob clockwise to increase the sensitivity.

IMPORTANT: The ST RATE knob will only adjust the sensitivity when the transmitter is bound to a DSMR® receiver. When the transmitter is bound to a DSM®, DSM2® or DSM Marine receiver, the ST RATE knob controls the steering dual rate.

RUN TIME

The largest factor in run time is the capacity of the battery pack. A larger mAh rating increases the amount of run time experienced.

The condition of a battery pack is also an important factor in both run time and speed. The battery connectors may become hot during driving. Batteries will lose performance and capacity over time.

Driving the vehicle from a stop to full speed repeatedly will damage the batteries and electronics over time. Sudden acceleration will also lead to shorter run times.

TO IMPROVE RUN TIMES

- Keep your vehicle clean and well maintained.
- Allow more airflow to the ESC and motor.
- Change the gearing to a lower ratio. A lower ratio decreases the operating temperature of the electronics. Use a smaller pinion gear or larger spur gear to lower the gear ratio.
- Use a battery pack with a higher mAh rating.
- Use the optimum charger to charge battery packs (Visit your local hobby dealer for more information).

PERFORMING A CONTROL DIRECTION TEST

Perform a control test with the vehicle wheels off the ground. If the wheels rotate after the vehicle is powered ON, adjust the TH Trim knob until they stop. To make the wheels move forward, pull the trigger. To reverse them, wait for the wheels to stop, then push the trigger. When moving forward, the wheels should maintain a straight line without any steering wheel input. If not, adjust the ST Trim knob, so the wheels maintain a straight line without having to turn the steering wheel.

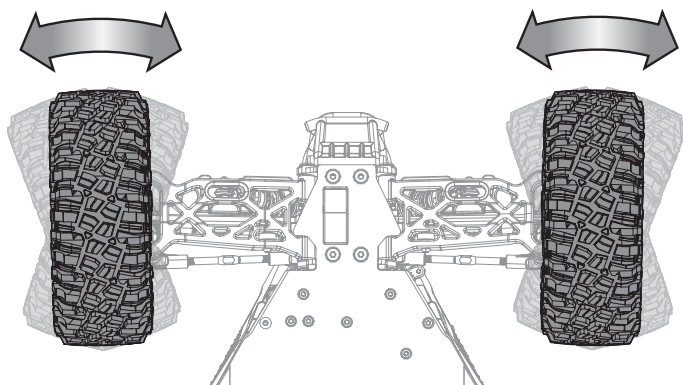

CHANGING THE TRAVEL ADJUST SETTINGS

Set the travel adjust settings with all four vehicle wheels off the ground. The throttle end point and brake end point adjustments will cause the wheels to spin at full speed. Have an assistant safely hold the vehicle securely while adjusting these settings.



CAUTION: Keep hands, hair and all loose clothing away from any moving parts, especially the wheels, while setting the travel adjust end points. Serious injury may result.

1. Hold the trigger in the full brake position and turn the steering wheel to full right while powering on the transmitter. The LED flashes rapidly, indicating programming mode is active.
2. Throttle End Point: Continue holding full throttle. Turn the TH TRIM knob to adjust the full throttle end point.
3. Brake End Point: Hold the trigger in the full brake position. Turn the TH TRIM knob to adjust the full brake end point. Return the trigger to the center position.
4. Left Steering End Point: Hold the steering wheel in the full left position. Turn the ST TRIM knob to adjust the left end point.
5. Right Steering End Point: Hold the steering wheel in the full right position. Turn the ST TRIM knob to adjust the right end point. Return the steering wheel to the center position.
6. Power off the transmitter to save the travel adjust settings.
The minimum Travel is 75%, and the Maximum travel is 150%.

IMPORTANT: If the travel is changed on the DX2E, you must rebind and calibrate the SRS6100AT.

SPEKTRUM™ FIRMA™ SMART 130A BRUSHLESS ESC (SPMXSE1130)

SPECIFICATIONS

Type	Sensorless, SMART Throttle Compatible
Output	130A/760A
Function	Forward/Brake—Forward/Brake Reverse
Input Voltage	7.4V–14.8V
BEC Output	6V/4A
Dimensions (LxWxH)	57.5mm x 46mm x 38mm
Weight	154 g

ESC LED STATUS

- No ESC LEDs will glow when there is no throttle input from the transmitter.
- The red ESC LED glows when there is any throttle input from the transmitter.

AUDIBLE WARNING TONES

1. **Input Voltage:** The ESC checks the input voltage when it is powered ON. If a voltage problem is detected, the ESC continuously sounds 2 beeps with a 1 second pause (xx-xx-xx). Power OFF the ESC and ensure the connections are secure and that the battery power is not too low for safe operation.
2. **Radio Connection:** The ESC checks radio signal input when it is powered ON. If a problem is detected, the ESC continuously sounds 1 beep with a 2 second pause (x--x--x). Power OFF the ESC and ensure the radio system is operating correctly.

NOTICE: Always disconnect the battery from the ESC after operating your vehicle. The ESC's switch only controls power to the receiver and servos. The ESC will continue to draw current when connected to the battery, resulting in possible damage to the battery through over discharge.

ESC CALIBRATION PROCEDURE

Complete the transmitter/receiver binding procedure prior to calibrating the ESC.

1. Set the transmitter throttle channel to 100% travel and center the throttle trim.
 2. Connect a battery to the ESC battery lead.
 3. Power on the transmitter.
 4. Press and hold the SET button while turning on the ESC. Release the SET button when the **red** LED begins to flash, indicating the ESC is in calibration mode. The ESC will enter programming mode if the button is held for more than three seconds.
- TIP:** The red LED should be flashing when the ESC enters calibration mode. If the green LED is flashing the ESC has entered programming mode. Power off the ESC and repeat step 4, releasing the SET button when the red LED begins to flash.
5. With the transmitter throttle trigger at the neutral position, press and release the ESC SET button. The red LED will stop flashing, the green LED will flash one time and the motor will make a tone to indicate the neutral position has been accepted.
 6. While holding the throttle trigger at the full throttle position, press and release the ESC SET button. The green LED will flash twice and the motor will make two tones to indicate the full throttle position has been accepted.
 7. While holding the throttle trigger at the full brake position, press and release the SET button. The green LED will flash three times and the motor will make three tones to indicate the full brake position has been accepted.

The motor will operate normally after calibration is completed.

ESC FUNCTIONS AND MODES

The ESC includes programming options so you can adjust the way your vehicle performs. Refer to the included programming table to adjust the ESC for your driving conditions.

PROGRAMMING TABLE

■ Default Settings

PROGRAMMING ITEMS	PROGRAMMING VALUE								
	1	2	3	4	5	6	7	8	9
1. Running Mode	Forward w/ brake	Forward/Reverse w/ brake	Forward/Reverse						
2. Drag Brake Force	0%	5%	10%	20%	40%	60%	80%	100%	
3. Low Voltage Cutoff	non-protection	2.6V/Cell	2.8V/Cell	3.0V/Cell	3.2V/Cell	3.4V/Cell			
4. Start Mode	Level 1	Level 2	Level 3	Level 4	Level 5	Level 6	Level 7	Level 8	Level 9
5. Max Brake Force	25%	50%	75%	100%	disable				
6. Max Reverse Force	25%	50%	75%	100%					
7. Initial Brake Force	= Drag Brake	0%	20%	40%					
8. Neutral Range	6% (Narrow)	9% (Normal)	12% (Wide)						
9. Timing	0.00°	3.75°	7.50°	11.25°	15.00°	18.75°	22.50°	26.25°	
10. Motor Rotation	Counterclockwise	Clockwise							
11. Li-Po Cells	Auto Calculate	2 Cells	3 Cells	4 Cells	5 Cells	6 Cells			

ESC PROGRAMMING PROCEDURE

Programming is accomplished using the SET button on the ON/OFF switch*.

1. Connect a fully charged battery to the ESC.
2. Power on the transmitter.
3. Power on the ESC.
4. Hold the SET button until the green LED flashes. Release the set button to enter programming mode.

TIP: To reset all programming items to the default values, press and hold the set button for five seconds

5. Press and release the set button as needed to cycle through the programming items. The number of times the green LED flashes equals the programming item number given in the programming table.
6. When at the desired programming item, press and hold the set button until the red LED flashes to select the item.
7. Press and release the SET button to cycle through the values available for the programming item based on the number of times the LED flashes. Refer to the programming table.
8. Save the setting by pressing and holding the SET button for 3 seconds.
9. Power off the ESC to exit programming mode or to change other programming items.

*Other programming options include the Spektrum SMART Firma ESC Programming Box (SPMXCA200) and the SmartLink USB updating and programmer application. See SpektrumRC.com for more details about Spektrum SMART Firma ESCs.

DESCRIPTIONS

1. Running Mode

- *Forward Only with Brake*
Intended for competition use, this mode allows only forward and brake controls.
- *Forward/Reverse with Brake*
This mode is the basic all-around mode, allowing forward, reverse and brake controls. To engage reverse while moving forward, apply the brake until the vehicle has come to a complete stop, release brake, then apply the brake again. While braking or in reverse, engaging the throttle will result in the vehicle immediately accelerating forward.

2. Drag Brake Force

Adjusts the amount of brake automatically applied when the throttle is returned to the neutral position. This simulates the engine braking effect of a full-scale vehicle, allowing improved turn-in and your vehicle's general response to controls.

3. Low Voltage Cutoff

This function helps to prevent battery over-discharge. The ESC continuously monitors the battery's voltage. If the voltage falls below the voltage threshold for 2 seconds, the output power shuts off and the red LED flashes twice repeatedly.

The cutoff threshold calculation is based on individual Li-Po cell voltage. For Ni-MH batteries, if the voltage battery pack is higher than 9.0V, it will be treated as a 3-cell Li-Po battery pack; if it is lower than 9.0V, it will be treated as a 2-cell Li-Po battery pack. Example: for a 8.0V Ni-MH battery pack used with a 2.6V/cell threshold, it will be treated as a 2-cell Li-Po battery pack and the low-voltage cut-off threshold will be 5.2V (2.6x2=5.2).

4. Start Mode (Punch)

Sets the initial throttle punch when the car accelerates. Level 1 gives a very soft initial acceleration and level 4 gives a stronger initial acceleration.

5. Max Brake Force

Adjusts the maximum braking force. A higher value provides stronger braking, but can also cause the wheels to lock, resulting in loss of control of the car.

6. Max Reverse Force

This parameter adjusts the maximum power when travelling in reverse.

7. Initial Brake Force (minimum brake)

Adjusts the minimum amount of braking power when the brakes engage. The default value is equal to the drag brake value. A high value can lock the wheels when the brake is used.

8. Neutral Range

Adjusts the throttle sensitivity around the neutral point. A higher value results in the throttle having to be moved more for the vehicle to move forward, backward or brake.

9. Timing

Adjusts the motor drive current timing. More timing gives more performance, but can lower efficiency and cause damage to the motor and/or ESC by overload or overheating.

NOTICE: Always ensure the motor timing is set correctly. Failure to set the motor timing correctly can result in damage to the motor and ESC. Refer to the manufacturer instructions for recommended timing settings.

10. Motor Type

11. Motor Rotation

Allows you to make this change in the ESC so no wires need to be changed between the ESC and the motor.

12. Li-Po Cells

Allows the ESC to automatically detect or manually set the number of cells in your Li-Po battery back.

SPEKTRUM™ FIRMA™ 1900KV BRUSHLESS MOTOR

PRECAUTIONS

- Never touch moving parts.
- Never disassemble while the batteries are installed.
- Always let parts cool before touching.

GEARING

Your vehicle has been equipped with the optimal gearing installed for the use of a 4S battery. It offers an ideal balance between speed, power and efficiency. Should you decide to customize your vehicle with a 3S battery it is necessary to change to the 14T pinion (included).

Installing a pinion gear with fewer teeth or a spur gear with more teeth will provide greater torque but will reduce top speed. Likewise, a pinion gear with more teeth or a spur gear with fewer teeth will reduce torque and increase top speed. Care should be taken when installing larger pinion gears as this can "overgear" the vehicle, resulting in overheating of the motor and ESC. When testing different gearing options, pay close attention to the temperature of the motor and speed control to ensure you are operating within the temperature range of the components. The motor or ESC should never be so hot that it cannot be touched. If temperatures are too hot, a different gearing combination with a lower pinion gear and/or higher spur gear is suggested.

CHANGING THE PINION GEAR/GEAR RATIO

1. Remove the screw holding the pinion gear cover in place.
2. Loosen the set screw and remove the installed pinion gear.
3. Loosen the motor screws and slide the motor back.
4. Place the new pinion on the end of the motor shaft so the set screw is located over the flat on the shaft.
5. Position it so the teeth line up with the spur gear and secure the pinion by tightening the set screw.
6. Set the gear mesh.

SETTING THE GEAR MESH

The gear mesh has already been set at the factory. Setting it is only necessary when changing motors or gears.

Proper gear mesh (how gear teeth meet) is important to the performance of the vehicle. When the gear mesh is too loose, the spur gear could be damaged by the pinion gear of the motor. If the mesh is too tight, speed could be limited and the motor and ESC will overheat.

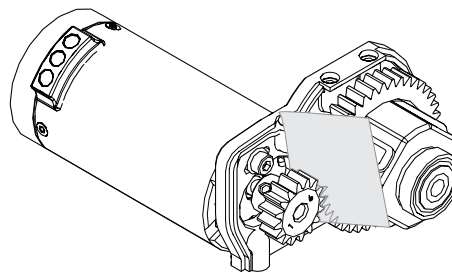

1. Loosen the motor screws and slide the motor back.
2. Put a small piece of paper between the pinion and spur gears.
3. Push the gears together while tightening the motor screws.
4. Remove the paper. Check the mesh at 3–5 different locations around the spur gear for a small amount of movement.
5. Install the gear cover.

NOTICE: If you are using a 3S Li-Po battery, use the included 14T Pinion gear. If you are using a 4S Li-Po battery, use the installed 12T pinion gear. Using a 14T pinion gear with a 4S Li-Po battery will result in damage to the ESC and motor.

TELEMETRY SETTINGS

If using the Spektrum Dashboard app or the optional speedometer module on your transmitter, set the motor pole count to 4 and the rollout distance to 1.5" (38.1mm).

TROUBLESHOOTING GUIDE

PROBLEM	POSSIBLE CAUSE	SOLUTION
Vehicle does not operate	Battery not charged or plugged in	Charge battery/plug in
	ESC switch not "On"	Turn on ESC switch
	Transmitter not "On" or low battery	Turn on/replace batteries
Motor runs but wheels do not rotate	Pinion not meshing with spur gear	Adjust pinion/spur mesh
	Pinion spinning on motor shaft	Tighten pinion gear setscrew on motor shaft flat spot
	Transmission gears stripped	Replace transmission gears
	Drive pin broken	Check and replace drive pin
Steering does not work	Servo plug not in receiver properly	Make sure the steering servo plug is connected to the receiver steering channel, noting proper polarity
	Servo gears or motor damaged	Replace or repair servo
Will not turn one direction	Servo gears damaged	Replace or repair servo
	Servo wire solder joint is damaged	Resolder the motor wire with the proper equipment
Motor does not run	Motor wire broken	Repair or replace as needed
	ESC damaged	Contact Horizon Hobby Product Support
	Motor over-gear	Use smaller pinion or larger spur gear
ESC gets hot	Driveline bound up	Check wheels and transmission for binding
	Battery pack not fully charged	Recharge battery
Poor run time and/or sluggish acceleration	Charger not allowing full charge	Try another charger
	Driveline bound up	Check wheels, transmission for binding
	Transmitter batteries low	Check and replace
Poor range and/or glitching	Vehicle battery low	Recharge battery
	Loose plugs or wires	Check all wire connections and plugs

LIMITED WARRANTY

What this Warranty Covers

Horizon Hobby, LLC, (Horizon) warrants to the original purchaser that the product purchased (the "Product") will be free from defects in materials and workmanship for a period of 2 years from the date of purchase.

What is Not Covered

This warranty is not transferable and does not cover (i) cosmetic damage, (ii) damage due to acts of God, accident, misuse, abuse, negligence, commercial use, or due to improper use, installation, operation or maintenance, (iii) modification of or to any part of the Product, (iv) attempted service by anyone other than a Horizon Hobby authorized service center, (v) Product not purchased from an authorized Horizon dealer, or (vi) Product not compliant with applicable technical regulations or (vii) use that violates any applicable laws, rules, or regulations. OTHER THAN THE EXPRESS WARRANTY ABOVE, HORIZON MAKES NO OTHER WARRANTY OR REPRESENTATION, AND HEREBY DISCLAIMS ANY AND ALL IMPLIED WARRANTIES, INCLUDING, WITHOUT LIMITATION, THE IMPLIED WARRANTIES OF NON-INFRINGEMENT, MERCHANTABILITY AND FITNESS FOR A PARTICULAR PURPOSE. THE PURCHASER ACKNOWLEDGES THAT THEY ALONE HAVE DETERMINED THAT THE PRODUCT WILL SUITABLY MEET THE REQUIREMENTS OF THE PURCHASER'S INTENDED USE.

Purchaser's Remedy

Horizon's sole obligation and purchaser's sole and exclusive remedy shall be that Horizon will, at its option, either (i) service, or (ii) replace, any Product determined by Horizon to be defective. Horizon reserves the right to inspect any and all Product(s) involved in a warranty claim. Service or replacement decisions are at the sole discretion of Horizon. Proof of purchase is required for all warranty claims. SERVICE OR REPLACEMENT AS PROVIDED UNDER THIS WARRANTY IS THE PURCHASER'S SOLE AND EXCLUSIVE REMEDY.

Limitation of Liability

HORIZON SHALL NOT BE LIABLE FOR SPECIAL, INDIRECT, INCIDENTAL OR CONSEQUENTIAL DAMAGES, LOSS OF PROFITS OR PRODUCTION OR COMMERCIAL LOSS IN ANY WAY, REGARDLESS OF WHETHER SUCH CLAIM IS BASED IN CONTRACT, WARRANTY, TORT, NEGLIGENCE, STRICT LIABILITY OR ANY OTHER THEORY OF LIABILITY, EVEN IF HORIZON HAS BEEN ADVISED OF THE POSSIBILITY OF SUCH DAMAGES. Further, in no event shall the liability of Horizon exceed the individual price of the Product on which liability is asserted. As Horizon has no control over use, setup, final assembly, modification or misuse, no liability shall be assumed nor accepted for any resulting damage or injury. By the act of use, setup or assembly, the user accepts all resulting liability. If you as the purchaser or user are not prepared to accept the liability associated with the use of the Product, purchaser is advised to return the Product immediately in new and unused condition to the place of purchase.

Law

These terms are governed by Illinois law (without regard to conflict of law principals). This warranty gives you specific legal rights, and you may also have other rights which vary from state to state. Horizon reserves the right to change or modify this warranty at any time without notice.

WARRANTY SERVICES**Questions, Assistance, and Services**

Your local hobby store and/or place of purchase cannot provide warranty support or service. Once assembly, setup or use of the Product has been started, you must contact your local distributor or Horizon directly. This will enable Horizon to better answer your questions and service you in the event that you may need any assistance. For questions or assistance, please visit our website at www.horizonhobby.com, submit a Product Support Inquiry, or call the toll free telephone number referenced in the Warranty and Service Contact Information section to speak with a Product Support representative.

Inspection or Services

If this Product needs to be inspected or serviced and is compliant in the country you live and use the Product in, please use the Horizon Online Service Request submission process found on our website or call Horizon to obtain a Return Merchandise Authorization (RMA) number. Pack the Product securely using a shipping carton. Please note that original boxes may be included, but are not designed to withstand the rigors of shipping without additional protection. Ship via a carrier that provides tracking and insurance for lost or damaged parcels, as Horizon is not responsible for merchandise until it arrives and is accepted at our facility. An Online Service Request is available at http://www.horizonhobby.com/content/service-center_render-service-center. If you do not have internet access, please contact Horizon Product Support to obtain a RMA number along with instructions for submitting your product for service. When calling Horizon, you will be asked to provide your complete name, street address, email address and phone number where you can be reached during business hours. When sending product into Horizon, please include your RMA number, a list of the included items, and a brief summary of the problem. A copy of your original sales receipt must be included for warranty consideration. Be sure your name, address, and RMA number are clearly written on the outside of the shipping carton.

NOTICE: Do not ship Li-Po batteries to Horizon. If you have any issue with a Li-Po battery, please contact the appropriate Horizon Product Support office.

Warranty Requirements

For Warranty consideration, you must include your original sales receipt verifying the proof-of-purchase date. Provided warranty conditions have been met, your Product will be serviced or replaced free of charge. Service or replacement decisions are at the sole discretion of Horizon.

Non-Warranty Service

Should your service not be covered by warranty, service will be completed and payment will be required without notification or estimate of the expense unless the expense exceeds 50% of the retail purchase cost. By submitting the item for service you are agreeing to payment of the service without notification. Service estimates are available upon request. You must include this request with your item submitted for service. Non-warranty service estimates will be billed a minimum of ½ hour of labor. In addition you will be billed for return freight. Horizon accepts money orders and cashier's checks, as well as Visa, MasterCard, American Express, and Discover cards. By submitting any item to Horizon for service, you are agreeing to Horizon's Terms and Conditions found on our website http://www.horizonhobby.com/content/service-center_render-service-center.

ATTENTION: Horizon service is limited to Product compliant in the country of use and ownership. If received, a non-compliant Product will not be serviced. Further, the sender will be responsible for arranging return shipment of the unserviced Product, through a carrier of the sender's choice and at the sender's expense. Horizon will hold non-compliant Product for a period of 60 days from notification, after which it will be discarded.

10/15

WARRANTY AND SERVICE CONTACT INFORMATION

Country of Purchase	Horizon Hobby	Contact Information	Address
United States of America	Horizon Service Center (Repairs and Repair Requests)	servicecenter.horizonhobby.com/RequestForm/	2904 Research Rd. Champaign, Illinois, 61822 USA
	Horizon Product Support (Product Technical Assistance)	productsupport@horizonhobby.com 877-504-0233	
	Sales	websales@horizonhobby.com 800-338-4639	
European Union	Horizon Technischer Service	service@horizonhobby.eu +49 (0) 4121 2655 100	Hanskampring 9 D 22885 Barsbüttel, Germany
	Sales: Horizon Hobby GmbH		

FCC INFORMATION

FCC ID: CONTAINS BRWKATY1T | FCC ID: CONTAINS BRWSR6100AT

Supplier's Declaration of Conformity
LOSI LASERNUT ULTRA 4 ROCK RACER, RTR: 1/10 4WD (LOS03028)

This device complies with part 15 of the FCC Rules. Operation is subject to the following two conditions: (1) This device may not cause harmful interference, and (2) this device must accept any interference received, including interference that may cause undesired operation.

CAUTION: changes or modifications not expressly approved by the party responsible for compliance could void the user's authority to operate the equipment.

NOTE: This equipment has been tested and found to comply with the limits for a Class B digital device, pursuant to part 15 of the FCC Rules. These limits are designed to provide reasonable protection against harmful interference in a residential installation. This equipment generates, uses and can radiate radio frequency energy and, if not installed and used in accordance with the instructions, may cause harmful interference to radio communications. However, there is no guarantee that interference will not occur in a particular installation. If this equipment does cause harmful interference to radio or television reception, which can be determined by turning the equipment off and on, the user is encouraged to try to correct the interference by one or more of the following measures:

- Reorient or relocate the receiving antenna.
- Increase the separation between the equipment and receiver.
- Connect the equipment into an outlet on a circuit different from that to which the receiver is connected.
- Consult the dealer or an experienced radio/TV technician for help.

Horizon Hobby, LLC
2904 Research Rd.,
Champaign, IL 61822
Email: compliance@horizonhobby.com
Web: HorizonHobby.com

IC INFORMATION

IC: CONTAINS 6157A-KATY1T | CONTAINS 6157A-SR6100AT

CAN ICES-3 (B)/NMB-3(B)

This device contains license-exempt transmitter(s)/receiver(s) that comply with Innovation, Science, and Economic Development Canada's license-exempt RSS(s). Operation is subject to the following 2 conditions:

This device may not cause interference.

This device must accept any interference, including interference that may cause undesired operation of the device.

COMPLIANCE INFORMATION FOR THE EUROPEAN UNION

EU Compliance Statement:

LOSI LASERNUT ULTRA 4 ROCK RACER, RTR: 1/10 4WD (LOS03028)

Hereby, Horizon Hobby, LLC declares that the device is in compliance with the following: EU Radio Equipment Directive 2014/53/EU.

The full text of the EU declaration of conformity is available at the following internet address: <https://www.horizonhobby.com/content/support-render-compliance>.

Transmitter:

Frequency Band: 2402.0–2478.0 MHz
Max EIRP: 17.5 dBm

Receiver:

Frequency Band: 2402-2478 MHz
Max EIRP: 20 dBm

EU Manufacturer of Record:

Horizon Hobby, LLC
2904 Research Road
Champaign, IL 61822 USA

EU Importer of Record:

Horizon Hobby, GmbH
Hanskampring 9
22885 Barsbüttel Germany

WEEE NOTICE:

This appliance is labeled in accordance with European Directive 2012/19/EU concerning waste of electrical and electronic equipment (WEEE). This label indicates that this product should not be disposed of with household waste. It should be deposited at an appropriate facility to enable recovery and recycling.



REPLACEMENT PARTS // TEILELISTE // LISTE DES PIÈCES DE RECHANGE // ELENCO DEI RICAMBI

Part #	English	Deutsch	Français	Italiano
LOS230072	Body Clip Leash (4)	Gehäuseklemme Schnur (4)	Laisse de clip de carrosserie (4)	Lacci per clip per carrozzeria (4)
LOS230075	Body Set, Blue, Painted	Karoseriesatz, blau, lackiert	Carrosserie, bleue, peinte	Kit carrozzeria a vernice blu
LOS230076	Body Set, Red, Painted	Karoseriesatz, rot, lackiert	Carrosserie, rouge, peinte	Kit carrozzeria a vernice rossa
LOS230077	Body Set, Clear	Karoseriesatz, farblos	Carrosserie, transparente	Kit carrozzeria trasparente
LOS230078	Cage Set	Käfigsatz	Ensemble cage	Kit scocca
LOS230079	LED, Cage Parts	LED, Käfigteile	LED, pièces de la cage	Parti scocca, LED
LOS230080	Spare Tire Rack	Ersatzreifenstange	Support de pneu de secours	Porta ruota di ricambio
LOS231026	Steering Bellcrank Set	Steuerungsumlenkhebelsatz	Ensemble leviers de renvoi de direction	Kit squadrette di sterzo
LOS231027	Steering Posts, Tubes & Hardware	Lenksäulen, Rohre und Hardware	Colonnes de direction, tubes et accessoires	Supporti, tubi e bulloneria dello sterzo
LOS231030	Chassis Support Set	Karosiereträgersatz	Ensemble support de châssis	Kit supporti telaio
LOS231031	Motor Mount	Motorhalterung	Support moteur	Supporto motore
LOS231033	Steering Drag Link & Hardware	Lenkzwischenstange & Hardware	Barre d'accouplement de la direction & accessoires	Tirante di sterzo e bulloneria
LOS231057	Rod Ends & Links	Stangenende und Verbindungen	Embouts de bielle et liaisons	Teste a snodo e aste
LOS231062	Aluminum Chassis	Aluminiumchassis	Châssis en aluminium	Telaio in alluminio
LOS231063	Side Guards	Seitenschutze	Protections latérales	Protezioni laterali
LOS231064	Top Deck, Battery Mount	Oberdeck, Akkuhalterung	Pont supérieur, support de batterie	Piano superiore, supporto batteria
LOS231065	Grid Set	Halterungssatz	Ensemble grille	Kit griglia
LOS232023	Diff Case Set	Differentialgehäusesatz	Ensemble boîtier de différentiel	Kit scatola diff.
LOS232024	Center Drive Coupler	Zentrale Antriebskupplung	Coupleur d'entraînement central	Attacco albero trasmissione
LOS232025	40T Spur Gear, Mod 1	40T-Stirnrad, Mod 1	Engrenage cylindrique 40 dents, Mod 1	Corona 40T, Mod 1
LOS232026	Diff Housing	Differentialgehäuse	Logement du différentiel	Carter differenziale
LOS232027	Front Ring & Pinion Gear Set	Vorderer Ring- und Zahnradtriebessatz	Ensemble anneau et engrenage à pignons avant	Kit pignone e corona anteriori
LOS232028	Rear Ring & Pinion Gear Set	Hinterer Ring- und Zahnradtriebessatz	Ensemble anneau et engrenage à pignons arrière	Kit pignone e corona posteriori
LOS232029	Diff Gear Set w/Hardware	Differentialtriebessatz mit Hardware	Ensemble engrenage de différentiel avec accessoires	Kit ingr. diff. con bulloneria
LOS232030	Outdrive, Diff (2)	Flexwelle, Diff (2)	Entraînement extérieur, différentiel (2)	Outdrive, diff.(2)
LOS232031	Wheel Hex Set (4)	Sechskantratsatz (4)	Ensemble écrous hexagonaux de roue (4)	Kit esagoni ruote (4)
LOS232032	Front/Rear Driveshafts (2)	Front/Heck Antriebswellen (2)	Arbres de transmission avant/arrière (2)	Alberi trasmissione ant./post. (2)
LOS232033	Front Center Dogbone (1)	Vorderes mittiges Dogbone (1)	Dogbone central avant (1)	Cardano centrale ant. (1)
LOS232034	Rear Center Dogbone (1)	Hinteres mittiges Dogbone (1)	Dogbone central arrière (1)	Cardano centrale post. (1)
LOS232054	Center Dogbone Set	Mittiger Dogbone-Satz	Ensemble dogbone central	Kit cardano centrale
LOS232055	Aluminum Diff Case	Aluminium-Differentialgehäuse	Ensemble différentiel en aluminium	Scatola diff. in alluminio
LOS233011	Shock Plastics Set	Kunststoff-Stoßdämpfersatz	Ensemble plastiques d'amortisseur	Kit plastiche ammortizzatori
LOS233013	Spring Set	Federsatz	Ensemble ressort	Kit molle
LOS233014	Rear Shock Shaft (2)	Hintere Kolbenstange (2)	Arbre d'amortisseur arrière (2)	Albero amm. post. (2)
LOS233015	Front Shock Shaft (2)	Vordere Kolbenstange (2)	Arbre d'amortisseur avant (2)	Albero amm. ant. (2)
LOS233025	Adjuster Nut	Einstellmutter	Écrou de réglage	Dado di registrazione
LOS233026	Aluminum Shock Caps	Aluminium Stoßdämpferkappen	Capuchons d'amortisseur en aluminium	Tappi amm. in alluminio
LOS233027	Aluminum Front Shock Bodies	Vordere Stoßdämpfergehäuse, Aluminium	Corps d'amortisseur avant en aluminium	Carcasse amm. in alluminio ant.
LOS233028	Aluminum Rear Shock Bodies	Hintere Stoßdämpfergehäuse, Aluminium	Corps d'amortisseur arrière en aluminium	Carcasse amm. in alluminio post.
LOS234016	Front Arm Set	Vorderarmsatz	Ensemble bras avant	Kit braccio anteriore
LOS234017	Rear Arm Set	Hinterarmsatz	Ensemble bras arrière	Kit braccio posteriore
LOS234018	Front Spindle & Carrier Set	Front-Spindel- & Trägersatz	Ensemble axe et support avant	Kit fuselli e portafuselli ant.
LOS234019	Front/Rear Pin Mount Cover Set	Vorderer/Hinterer Stift Halterungsabdeckungssatz	Ensemble cache de support axe FR/R	Kit protezione montanti perni ant/post.
LOS234020	Rear Hub Set	Hinterradnabensatz	Ensemble moyeu arrière	Kit mozzi posteriori
LOS234021	Hingepin & Kingpin Set	Scharnierstift & Sattelzapfensatz	Ensemble axe de charnière et axe de pivot	Kit perni e cardini
LOS234023	Pivot Pin Mount Set, Steel (4)	Drehzapfensatz, Stahl (4)	Ensemble support axe de pivot, acier (4)	Kit supporto perno girevole, acciaio (4)
LOS234035	Aluminum Front Shock Tow	Vordere Aluminium-Stoßdämpferbrücke	Tour d'amortisseur avant en aluminium	Torre amm. in alluminio, ant.
LOS234036	Aluminum Rear Shock Tow	Hintere Aluminium-Stoßdämpferbrücke	Tour d'amortisseur arrière en aluminium	Torre amm. in alluminio, post.
LOS234037	Sway Bar Set	Schwingen-Set	Ensemble barre stabilisatrice	Kit barra antirollio
LOS234038	Rear Sway Bar Set	Heck Schwingen-Satz	Ensemble barre stabilisatrice arrière	Kit barra antirollio posteriore
LOS235011	Set Screw, M3 x 3mm Cup Point (10)	Stellschraube M3 x 3 mm Ringschneide (10)	Vis de fixation M3 x 3 mm Bout cuvette (10)	Kit viti, M3 x 3 mm, senza testa (10)
LOS235012	Set Screw, M4 x 4mm Cup Point (10)	Stellschraube M4 x 4 mm Ringschneide (10)	Vis de fixation M4 x 4 mm Bout cuvette (10)	Kit viti, M4 x 4 mm, senza testa (10)
LOS235024	Button Head Screw, M3 x 25mm (10)	Rundkopfschraube, M3 x 25mm (10)	Vis à tête bombée M3 x 25 mm (10)	Viti a testa tonda, M3 x 25 mm (10)
LOS235025	Button Head Screw, M3 x 30mm (10)	Rundkopfschraube, M3 x 30mm (10)	Vis à tête bombée M3 x 30 mm (10)	Viti a testa tonda, M3 x 30 mm (10)
LOS235026	Set Screw, M3 x 4mm Cup Point (10)	Stellschraube M3 x 4mm Ringschneide (10)	Vis de fixation M3 x 4mm Bout cuvette (10)	Kit viti, M3 x 4 mm, senza testa (10)
LOS235027	Set Screw, M3 x 10mm Cup Point (10)	Stellschraube M3 x 10mm Ringschneide (10)	Vis de fixation M3 x 10mm Bout cuvette (10)	Kit viti, M3 x 10 mm, senza testa (10)

REPLACEMENT PARTS // TEILELISTE // LISTE DES PIÈCES DE RECHANGE // ELENCO DEI RICAMBI

Part #	English	Deutsch	Français	Italiano
LOS236000	E-Clips 2.5mm (12)	E-Klemmen, 2,5 mm (12)	Attaches en E 2,5 mm (12)	E-Clip 2,5 mm (12)
LOS236001	3.2 x 7 x .5mm Washer (10)	3,2 x 7 x 5mm Unterlegscheibe (10)	Rondelle 3,2 x 7 x 0,5 mm (10)	Rondelle 3,2 x 7 x 0,5 mm (10)
LOS237000	12 x 18 x 4mm Ball Bearing (4)	12 x 18 x 4mm, Kugellager (4)	Roulement à billes 12 x 18 x 4 mm (4)	Cuscinetto a sfera 12 x 18 x 4 mm (4)
LOS237001	10 x 15 x 4mm Ball Bearing (4)	10 x 15 x 4mm, Kugellager (4)	Roulement à billes 10 x 15 x 4 mm (4)	Cuscinetto a sfera 10 x 15 x 4 mm (4)
LOS237002	5 x 11 x 4mm Ball Bearing (4)	5 x 11 x 4mm, Kugellager (4)	Roulement à billes 5 x 11 x 4 mm (4)	Cuscinetto a sfera 5 x 11 x 4 mm (4)
LOS43028	Wheel w/BFG Tire, Copper	Rad mit BFG-Reifen, Kupfer	Roue avec pneu BFG, cuivre	Ruota con pneumatico BFG, rame
LOSA3572	1.0 Module Pitch Pinion, 12T	1.0 Modul Getrieberad, 12T	Module de pignon de pas 1.0, 12 dents	Pignone Modulo 1.0, 12T
LOSA3574	1.0 Module Pitch Pinion, 14T	1.0 Modul Getrieberad, 14T	Module de pignon de pas 1.0, 14 dents	Pignone Modulo 1.0, 14T
LOSA6940	6 x 12mm Sealed Ball Bearing (4)	6 x 12mm abgedichtetes Kugellager (4)	Roulement à billes hermétique 6 x 12 mm (4)	Cuscinetti a sfera sigillati 6 x 12 mm (4)
SPM2340	DX3 SMART DSMR 3CH Transmitter w/SR315	DX3 SMART DSMR-Sender mit 3 Kanälen mit SR315	Émetteur DX3 SMART DSMR 3 canaux avec SR315	Trasmittente DX3 SMART DSMR 3 CH con SR315
SPMS614	S614 Metal Gear Servo, 23T WP	S614 Metallgetriebeservo 23T WP	Servo à engrenages métalliques S614, 23 dents, étanche	Servo ingr. in metallo S614 23T WP
SPMSR6100AT	SR6100AT DSMR 6CH AVC Telemetry Surface Receiver	SR6100AT DSMR AVC Telemetrie Oberflächenempfänger mit 6 Kanälen	Récepteur de surface de télémétrie AVC 6 canaux SR6100AT DSMR	Ricevitore di superficie con telemetria SR6100AT DSMR 6CH AVC
SPMXSE1130	Firma 130A Brushless Smart ESC	Firma 130 A Bürstenloser Smart-Geschwindigkeitsregler	Variateur ESC sans balais 130 A Smart Firma	Smart ESC Firma 130 A Brushless
SPMXSM2200	3668-1900Kv Motor	3668 - 1900Kv Motor	Moteur 3668 - 1900Kv	Motore 3668 - 1900Kv
TLR5280	Silicone Differential Fluid, 5,000CS	Differential-Silikonflüssigkeit, 5.000CS	Liquide silicone pour différentiel, 5 000 CS	Fluido siliconico per differenziale, 5.000 CS
TLR5282	Silicone Differential Fluid, 10,000CS	Differential-Silikonflüssigkeit, 10.000CS	Liquide silicone pour différentiel, 10 000 CS	Fluido siliconico per differenziale, 10.000 CS
TLR5284	Silicone Differential Fluid, 20,000CS	Differential-Silikonflüssigkeit, 20.000CS	Liquide silicone pour différentiel, 20 000 CS	Fluido siliconico per differenziale, 20.000 CS
TLR5901	Button Head Screw, M3 x 6mm (10)	Rundkopfschraube, M3 x 6mm (10)	Vis à tête bombée M3 x 6mm (10)	Viti a testa tonda, M3 x 6 mm (10)
TLR5902	Button Head Screw, M3 x 8mm (10)	Rundkopfschraube, M3 x 8mm (10)	Vis à tête bombée M3 x 8mm (10)	Viti a testa tonda, M3 x 8 mm (10)
TLR5903	Button Head Screw, M3 x 10mm (10)	Rundkopfschraube, M3 x 10mm (10)	Vis à tête bombée M3 x 10mm (10)	Viti a testa tonda, M3 x 10 mm (10)
TLR5904	Button Head Screw, M3 x 12mm (10)	Rundkopfschraube, M3 x 12mm (10)	Vis à tête bombée M3 x 12mm (10)	Viti a testa tonda, M3 x 12 mm (10)
TLR5905	Button Head Screw, M3 x 18mm (10)	Rundkopfschraube, M3 x 18mm (10)	Vis à tête bombée M3 x 18mm (10)	Viti a testa tonda, M3 x 18 mm (10)
TLR5908	Button Head Screw, M3 x 44mm (4)	Rundkopfschraube, M3 x 44mm (4)	Vis à tête bombée M3 x 44mm (4)	Viti a testa tonda, M3 x 44 mm (4)
TLR5909	Button Head Screw, M3 x 16mm (10)	Rundkopfschraube, M3 x 16mm (10)	Vis à tête bombée M3 x 16mm (10)	Viti a testa tonda, M3 x 16 mm (10)
TLR5910	Button Head Screw, M3 x 14mm (10)	Rundkopfschraube, M3 x 14mm (10)	Vis à tête bombée M3 x 14mm (10)	Viti a testa tonda, M3 x 14 mm (10)
TLR5911	Button Head Screw, M3 x 20mm (10)	Rundkopfschraube, M3 x 20mm (10)	Vis à tête bombée M3 x 20mm (10)	Viti a testa tonda, M3 x 20 mm (10)
TLR5914	Button Head Screw, M2 x 12mm (10)	Rundkopfschraube, M2 x 12mm (10)	Vis à tête bombée, M2 x 12mm (10)	Viti a testa tonda, M2 x 12 mm (10)
TLR5932	Cap Head Screw, M3 x 10mm (10)	Inbusschraube, M3 x 10mm (10)	Vis d'assemblage creuse, M3 x 10mm (10)	Viti a testa cilindrica, M3 x 10 mm (10)
TLR5933	Cap Head Screw, M3 x 12mm (10)	Inbusschraube, M3 x 12mm (10)	Vis d'assemblage creuse, M3 x 12mm (10)	Viti a testa cilindrica, M3 x 12 mm (10)
TLR5962	Flathead Screw, M3 x 10mm (10)	Flachkopfschraube, M3 x 10mm (10)	Vis à tête plate, M3 x 10mm (10)	Viti a testa piana, M3 x 10 mm (10)
TLR5963	Flathead Screw, M3 x 12mm (10)	Flachkopfschraube, M3 x 12mm (10)	Vis à tête plate, M3 x 12mm (10)	Viti a testa piana, M3 x 12 mm (10)
TLR5964	Flathead Screw, M3 x 16mm (10)	Flachkopfschraube, M3 x 16mm (10)	Vis à tête plate, M3 x 16mm (10)	Viti a testa piana, M3 x 16 mm (10)
TLR5965	Flathead Screw, M3 x 20mm (10)	Flachkopfschraube, M3 x 20mm (10)	Vis à tête plate, M3 x 20mm (10)	Viti a testa piana, M3 x 20 mm (10)
TLR6313	Locknut, M3 x .5 x 5.5mm (10)	Kontermutter, M3 x 0,5 x 5,5 mm (10)	Contre-écrou M3 x 5 x 5,5 mm (10)	Controdadi, M3 x 0,5 x 5,5 mm (10)
TLR6352	Washers, M3 (10)	Unterlegscheiben, M3 (10)	Rondelles, M3 (10)	Rondelle, M3 (10)
TLR8202	Body Clips, Black (12)	Gehäuseklemmen, schwarz (12)	Clips de carrosserie, noir (12)	Clip carrozzeria, colore nero (12)
TLR74008	Silicone Shock Oil, 35 wt, 2 oz	Stoßdämpfer-Silikonöl, 35 wt, 59 ml (2 oz)	Huile silicone pour amortisseurs, 35 wt, 59 mL	Olio di silicone per ammortizzatori, 35 wt, 60 ml (2 oz)
TLR235007	Flat Head Screw, M2.5 x 10mm (10)	Flachkopfschraube M2,5 x 10mm (10)	Vis à tête plate M2,5 x 10 mm (10)	Smart ESC Firma 130 A Brushless
TLR255008	Button Head Screw, M4 x 16mm (10)	Rundkopfschraube, M4 x 16mm (10)	Vis à tête bombée, M4 x 16 mm (10)	Viti a testa tonda, M4 x 16 mm (10)
TLR255013	Flat Head Screws, M4 x 12mm (10)	Rundkopfschrauben, M4 x 12mm (10)	Vis à tête plate, M4 x 12mm (10)	Viti a testa piana, M4 x 12 mm (10)
TLR256005	Nylock Nut, M4 (10)	Nylock-Mutter, M4 (10)	Contre-écrou Nylock, M4 (10)	Dado Nylock, M4 (10)
TLR336005	M3 Flanged Aluminum Locknut, Black (10)	M3 Aluminium-Kontermutter mit Flansch, schwarz (10)	Contre-écrou M3 en aluminium à collet, noir (10)	Controdado alluminio flangiato M3, nero (10)

RECOMMENDED PARTS // EMPFOHLENE TEILE// PIÈCES RECOMMANDÉES // PARTI CONSIGLIATE

Part #	English	Deutsch	Français	Italiano
DYNC2005CA	Prophet Sport LiPo 35W AC Charger	Prophet Sport LiPo 35 W AC-Ladegerät	Chargeur CA Li-Po 35 W Prophet Sport	Caricabatteria Prophet Sport LiPo 35 W CA
SPMX1080	Spektrum Smart S100 AC Charger	Spectrum Smart S100 Wechselstrom-Ladegerät	Chargeur CA Spektrum Smart S100	Caricabatteria Spektrum Smart S100 CA
SPMX50003S50H5	11.1V 5000mAh 3S 50C Smart Hardcase LiPo Battery: IC5	11,1 V 5000 mAh 3S 50C Smart LiPo-Akku, Hartschale: IC5	Batterie LiPo Smart 11,1 V 5 000 mAh 3S 50C, boîtier rigide : IC5	Batteria Li-Po 11,1 V 5000 mAh 3S 50C Smart Hardcase: IC5
SPMX50004S50H5	14.8V 5000mAh 4S 50C Smart Hardcase LiPo Battery: IC5	14,8 V 5000 mAh 4S 50C Smart LiPo-Akku, Hartschale: IC5	Batterie LiPo Smart 14,8V 5 000 mAh 4S 50C, boîtier rigide : IC5	Batteria Li-Po 14,8 V 5000 mAh 4S 50C Smart Hardcase: IC5

OPTIONAL PARTS // OPTIONALE TEILE // PIÈCES OPTIONNELLES // PARTI OPZIONALI

Part #	English	Deutsch	Français	Italiano
DYN2834	Startup Tool Set: Metric	Anfänger-Werkzeugsatz: Metrisch	Jeu d'outils de démarrage : Métrique	Kit completo attrezzi base: metrico
DYN5500	Magnum Force 2 Motor Spray, 13 oz	Magnum Force 2 Motorspray, 368 g	Vaporisateur pour moteur Magnum Force 2, 368 g	Spray per motore Magnum Force 2, 385 ml (13 oz)
DYNT2010	Machined Nut Driver Set (4) Metric	Set gefräste Steckschlüssel (4) metrisch	Ensemble tourne-écrou usiné (4) Métrique	Kit di chiavi (4) metriche
DYNT2030	Machined Hex Driver Set (4) Met	Set gefräste Inbusschraubendreher (4) Met	Ensemble clé à six pans usinée (4) Métrique	Kit di chiavi a brugola (4) metriche
LOS331012	Mach Alum Motor Mount	Gefräste Motorhalterung, Aluminium	Support moteur en aluminium usiné	Supporto motore in alluminio lavorato
LOS334011	Aluminum Rear Hubs (2)	Hintere Naben, Aluminium (2)	Moyeux arrière en aluminium (2)	Mozzi in alluminio, post. (2)
LOS334012	Aluminum Front Spindle (2)	Front-Spindel, Aluminium (2)	Axe avant en aluminium (2)	Fuselli in alluminio, ant. (2)
LOS334013	Aluminum Spindle Carrier (2)	Spindelträger, Aluminium (2)	Support d'axe en aluminium (2)	Portafuselli in alluminio (2)
LOS43011	Desert Claws Tires w/Foam, Soft (2)	Desert Claws-Reifen mit Schaumstoff (2)	Pneus Desert Claws avec mousse, douce (2)	Pneumatici Desert Claw con schiuma, morbidi (2)
LOSA3571	1.0 Module Pitch Pinion, 11T	1.0 Modul Getrieberad, 11T	Module de pignon de pas 1.0, 11 dents	Pignone Modulo 1.0, 11T
LOSA3573	1.0 Module Pitch Pinion, 13T	1.0 Modul Getrieberad, 13T	Module de pignon de pas 1.0, 13 dents	Pignone Modulo 1.0, 13T
LOSA3576	1.0 Module Pitch Pinion, 16T	1.0 Modul Getrieberad, 16T	Module de pignon de pas 1.0, 16 dents	Pignone Modulo 1.0, 16T
LOSA3578	1.0 Module Pitch Pinion, 18T	1.0 Modul Getrieberad, 18T	Module de pignon de pas 1.0, 18 dents	Pignone Modulo 1.0, 18T
LOSA99173	Ride Height Gauge	Höhenmesser	Jauge de hauteur de course	Misuratore altezza di marcia
LOSA99174	Car Stand	Fahrzeugständer	Socle	Supporto automodello
LOSB3493	Aluminum Clamping Wheel Hex	Aluminium Klemmrad Sechskant	Roue de serrage hexagonale en aluminium	Rotella di bloccaggio esagonale in alluminio
SPM6730	Spektrum Tx Storage Bag*	Spektrum Tx Aufbewahrungstasche*	Sac de rangement Spektrum Tx*	Sacco custodia Tx Spektrum
SPMSS6230	S6230 U-T / M-S Digital WP Servo	S6230 U-T/M-S Digitaler WP Servo	Servo numérique S6230 U-T / M-S WP	Servo impermeabile digitale S6230 U-T/M-S
TLR332014	Rear Hex, +0.5mm Width, Aluminum	Hinterer Sechskant, +0,5 mm Breite, Aluminium	Écrou hexagonal arrière, +0,5 mm de largeur, aluminium	Esagono posteriore, larghezza +0,5 mm, alluminio
TLR336000	4mm Aluminum Serrated Lock Nut, Black (6)	4 mm Aluminium Rändelmutter, schwarz (6)	Contre-écrou en aluminium à embase striée 4 mm, noir (6)	Controdado dentato in alluminio 4 mm, nero (6)
TLR336001	4mm Aluminum Serrated Lock Nut, Blue (6)	4 mm Aluminium Rändelmutter, blau (6)	Contre-écrou en aluminium à embase striée 4 mm, bleu (6)	Controdado dentato in alluminio 4 mm, blu (6)
TLR5062	Bleeder Shock Cap, Aluminum (2)	Stoßdämpfer-Entlüfterkappe, Aluminium (2)	Contre-écrou en aluminium à embase striée 4 mm, bleu (6)	Tappi di sfianto per ammortizzatori, alluminio (2)
TLR74006	Silicone Shock Oil, 30 wt, 2 oz	Stoßdämpfer-Silikonöl, 30 wt, 59 ml (2 oz)	Huile silicone pour amortisseurs, 30 WT, 59 mL	Olio di silicone per ammortizzatori, 30 wt, 60 ml (2 oz)
TLR74010	Silicone Shock Oil, 40 wt, 2 oz	Stoßdämpfer-Silikonöl, 40 wt, 59 ml (2 oz)	Huile silicone pour amortisseurs, 40 WT, 59 mL	Olio di silicone per ammortizzatori, 40 wt, 60 ml (2 oz)
TLR76000	Tire Glue, Standard	Reifenklebemittel, Standard	Colle de pneu, standard	Colla pneumatici, standard
TLR76004	TLR Lok, Threadlock, Blue	TLR Lok, Schraubensicherung, blau	Verrou TLR, frein-filet, bleu	TLR Lok, frenafiletli, blu

EXPLODED VIEW // EXPLOSIONSZEICHNUNG // VUE ÉCLATÉE DES PIÈCES // VISTA ESPLOSA DELLE PARTI

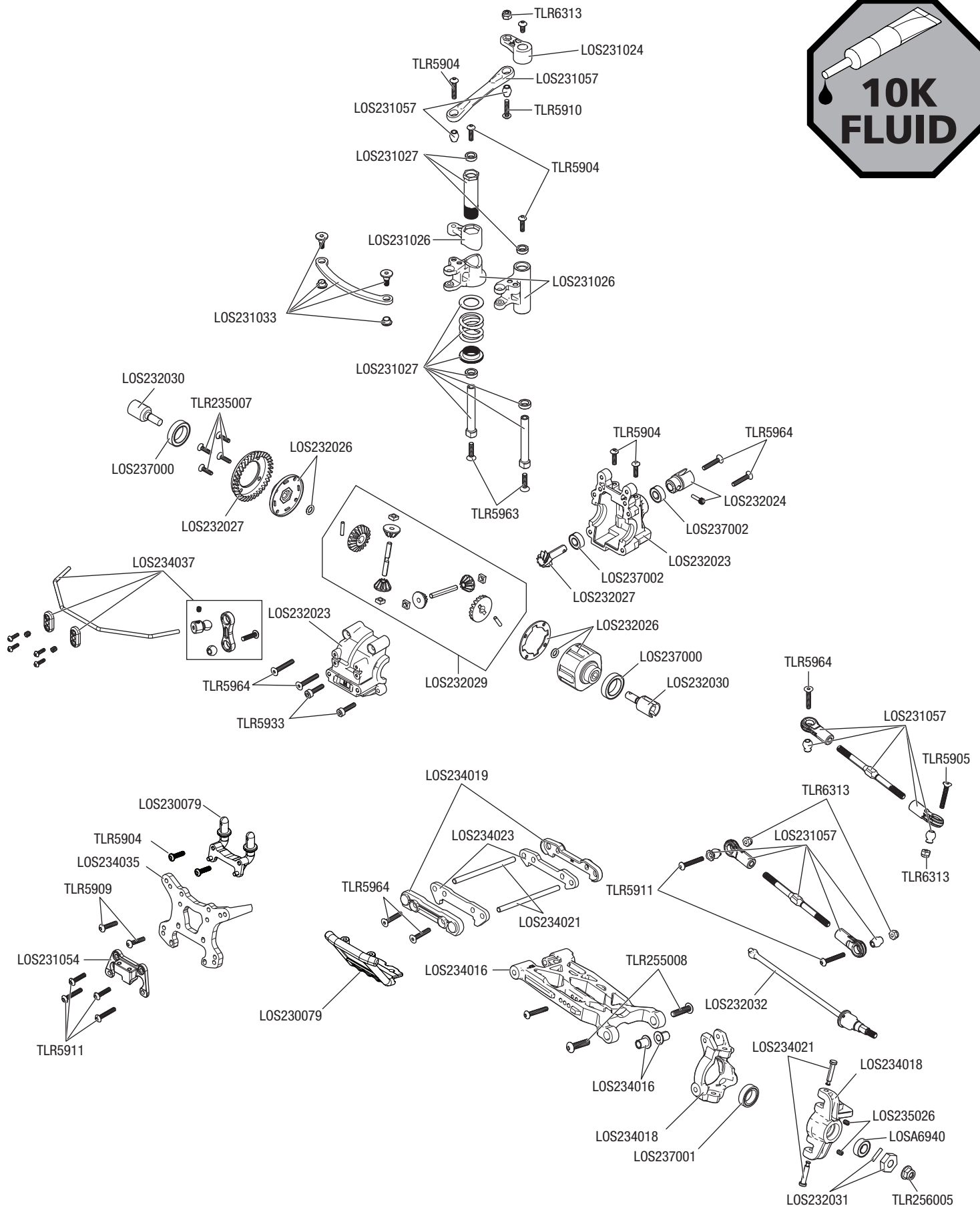

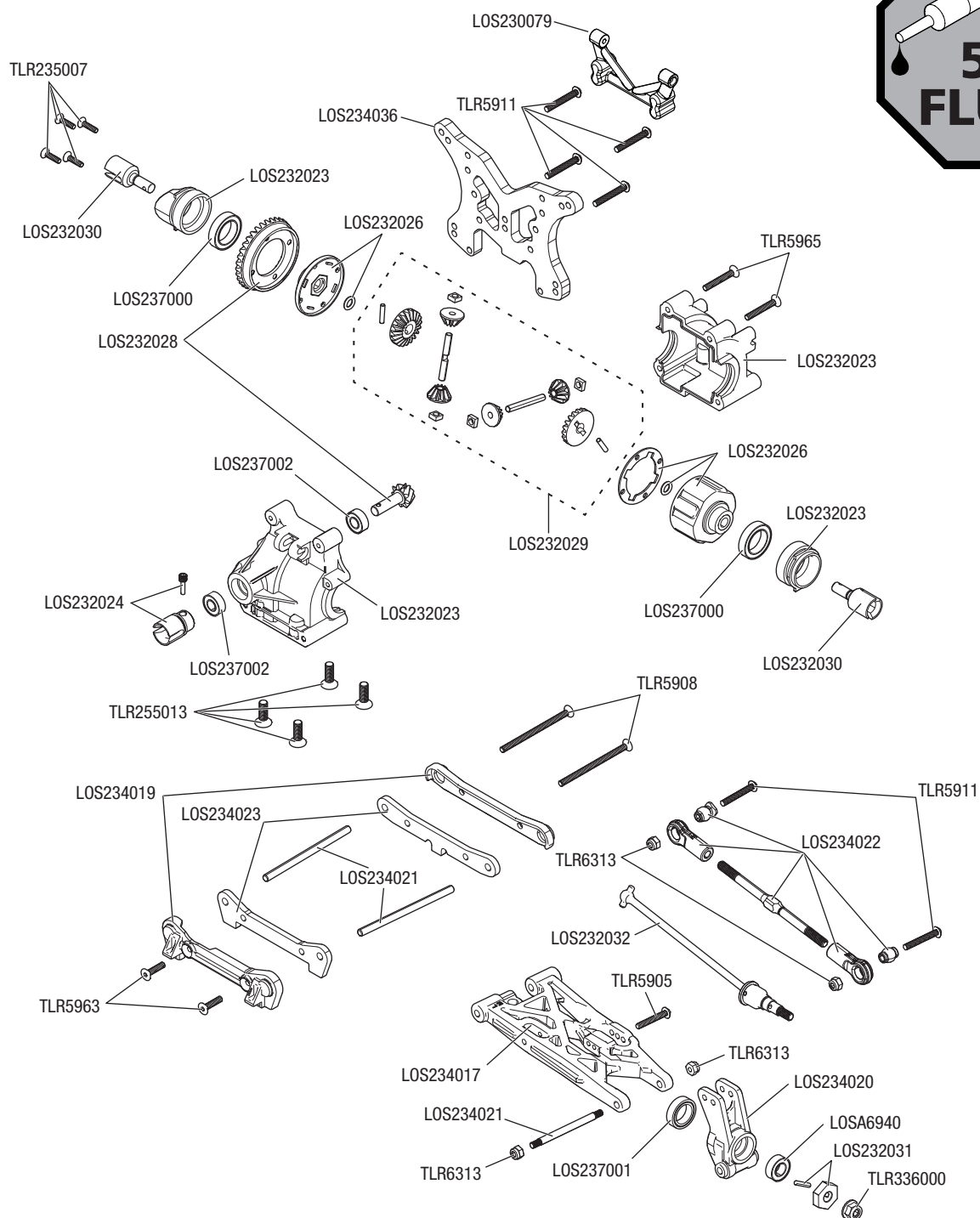

EXPLODED VIEW // EXPLOSIONSZEICHNUNG // VUE ÉCLATÉE DES PIÈCES // VISTA ESPLOSA DELLE PARTI

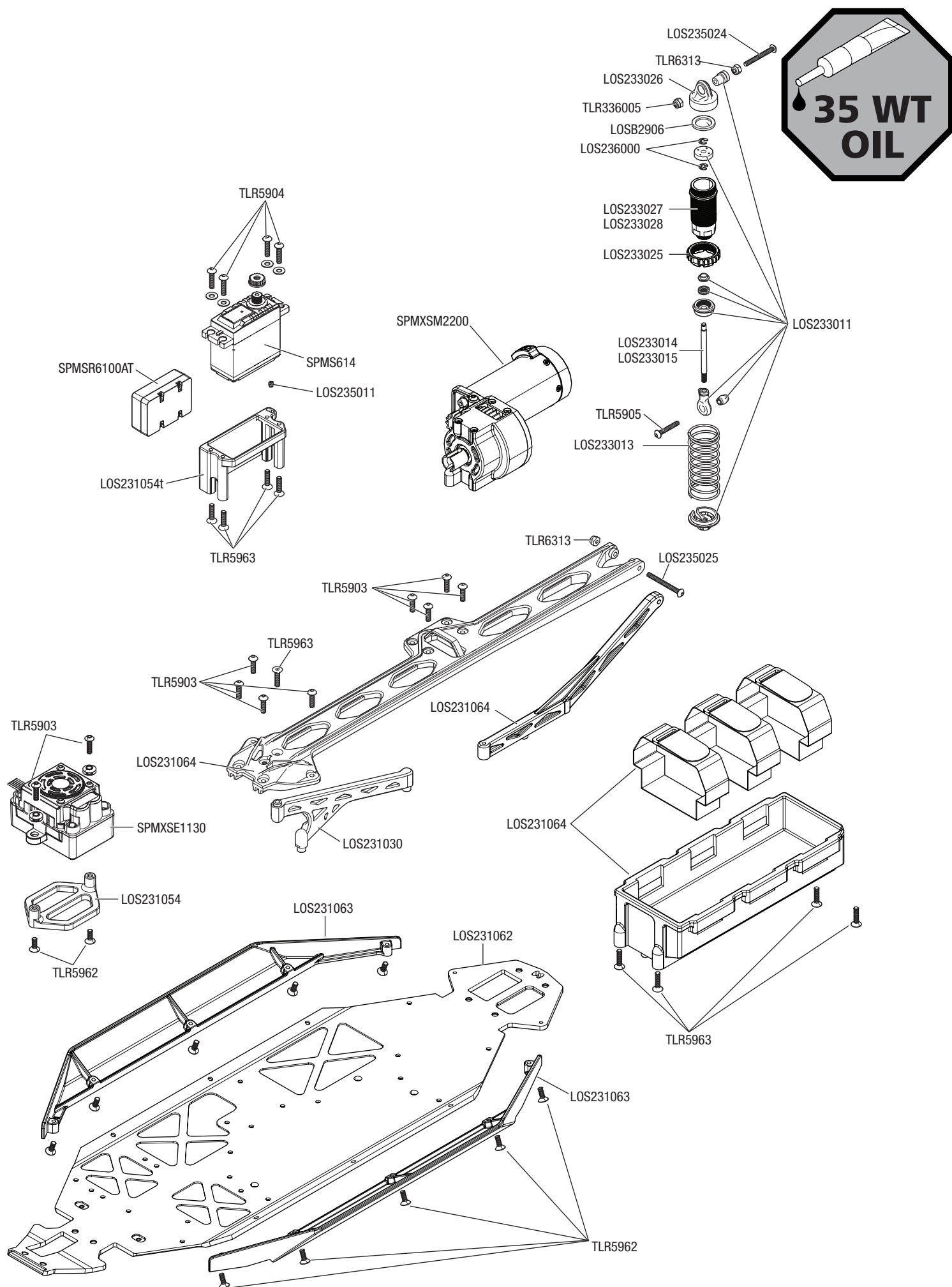

EXPLODED VIEW // EXPLOSIONSZEICHNUNG // VUE ÉCLATÉE DES PIÈCES // VISTA ESPLOSA DELLE PARTI

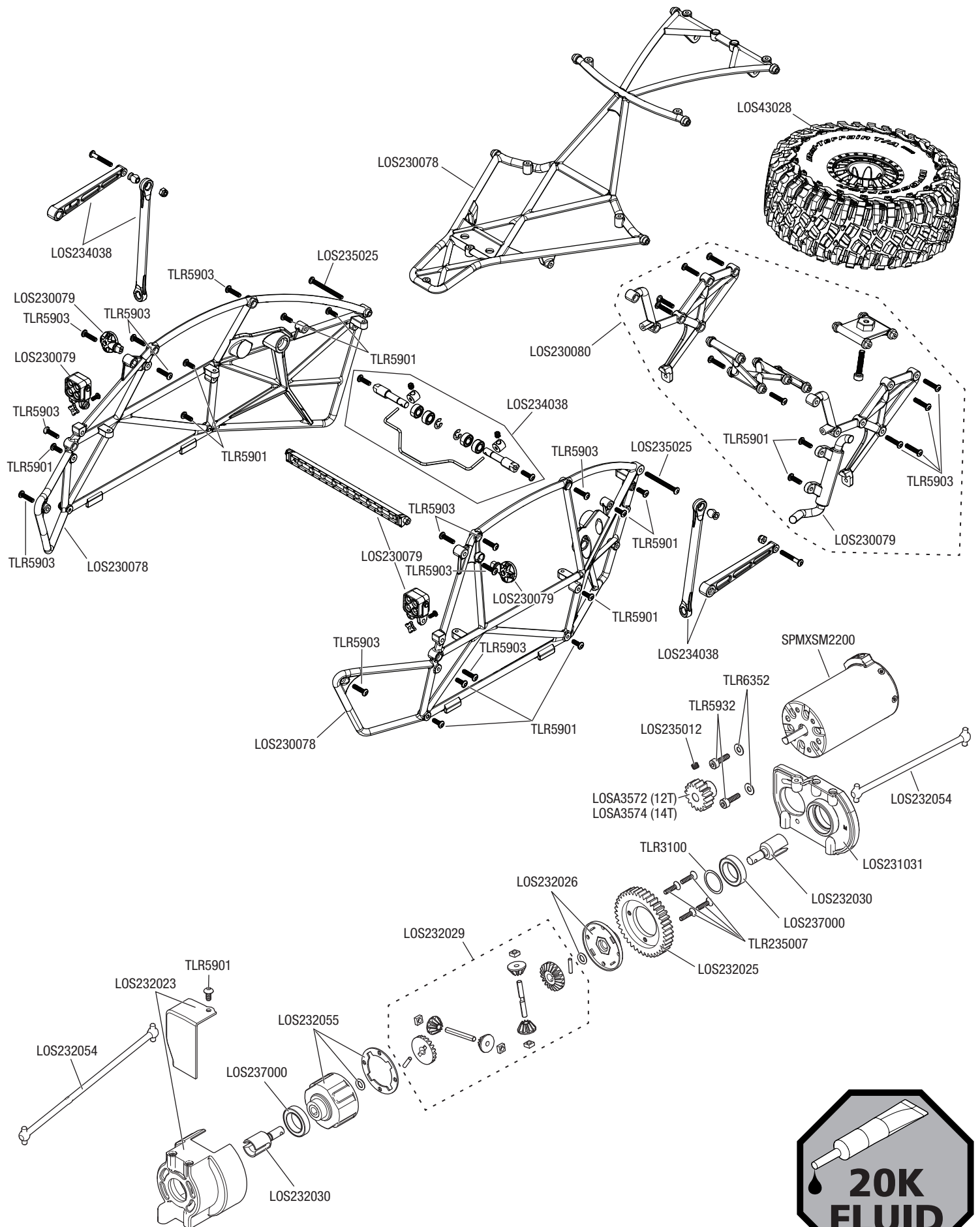

EXPLODED VIEW // EXPLOSIONSZEICHNUNG // VUE ÉCLATÉE DES PIÈCES // VISTA ESPLOSA DELLE PARTI

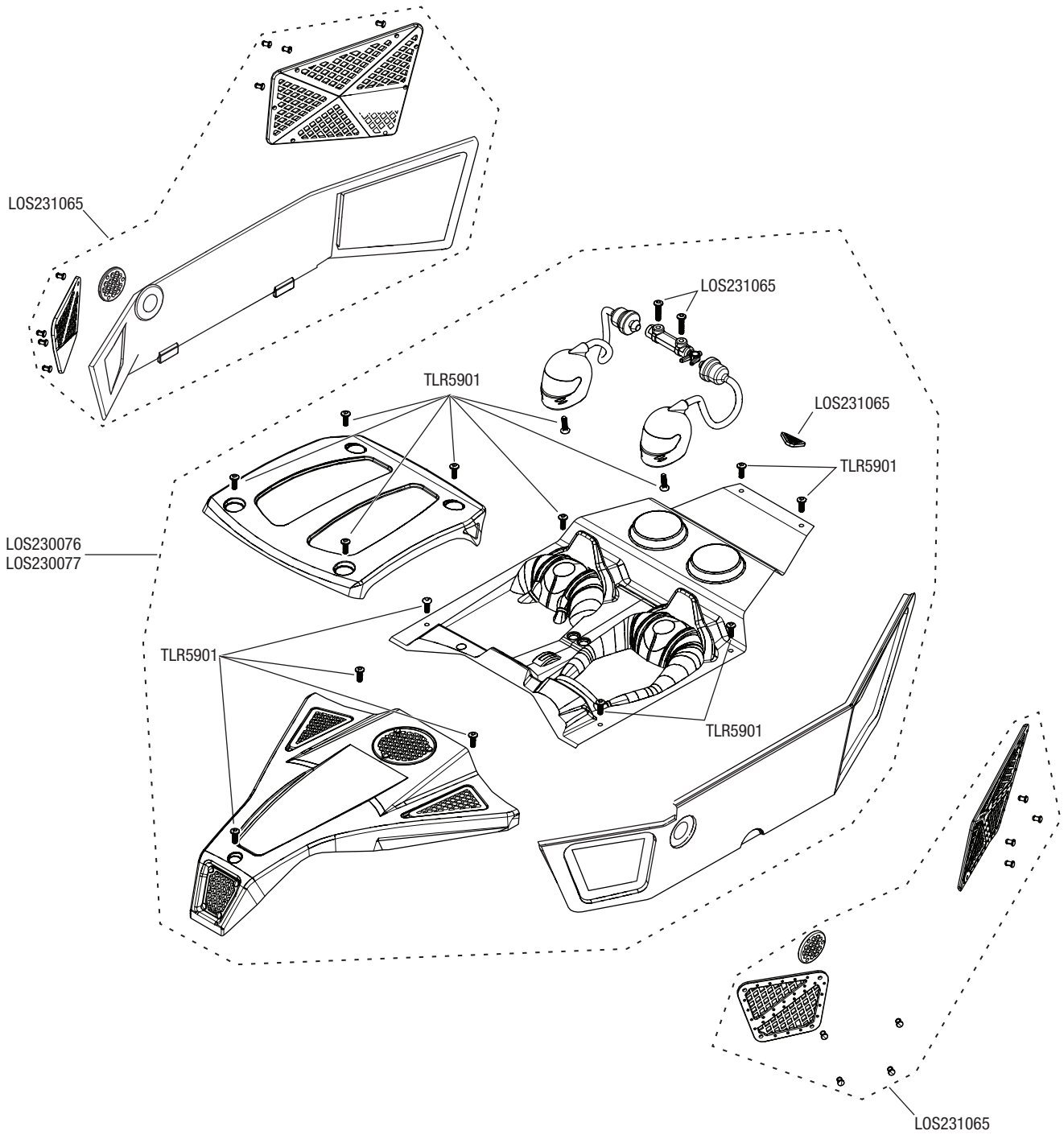



WWW.LOSI.COM

60778.2 | ©2021 Horizon Hobby, LLC.

Losi, Tenacity, Firma, DX3, DSM, DSM2, DSMR, AVC, Active Vehicle Control, Fuze, IC5 and the Horizon Hobby logo are trademarks or registered trademarks of Horizon Hobby, LLC. The Spektrum trademark is used with permission of Bachmann Industries, Inc. The Lasernut name and logo and vehicle cage design are property of Cody Waggoner, used under license.

All other trademarks, service marks and logos are property of their respective owners.

US 9,320,977, US 10,528,060, US 9,930,567, US 10,419,970, US 10,849,013. Other patents pending.

Updated 03/21 | LOS03028

