



# CESSNA 208 GRAND CARAVAN 85 INCH WINGSPAN 35-40CC

Code : SEA 362

## ASSEMBLY MANUAL

“Graphics and specifications may change without notice”.



### Specifications:

Wingspan----- 85.0 in (215.9 cm).

Wing area----- 775.0 sq.ins (59.0 sq.dm).

Weight----- 16.8lbs (7.6 kg).

Length----- 59.2 in (150.3 cm).

Engine/Motor size----- 35-40cc gasoline.

Radio----- 8 channels with 9 servos.

Motor 160/ 2700watt/ ESC 70A-100A/ Lipo 9s-10s.

Electric propeller 18x8-20x10.

## INTRODUCTION

Thank you for choosing the CESSNA 208 GRAND CARAVAN ARTF by SG MODELS . The 85" CESSNA GRAND CARAVAN was designed with the intermediate/advanced sport flyer in mind. It is a semi scale airplane which is easy to fly and quick to assemble. The airframe is conventionally built using balsa, plywood to make it stronger than the average ARTF, yet the design allows the aeroplane to be kept light. You will find that most of the work has been done for you already. The motor mount has been fitted and the hinges are pre-installed. Flying the CESSNA 208 GRAND CARAVAN is simply a joy.

This instruction manual is designed to help you build a great flying aeroplane. Please read this manual throughly before starting assembly of your CESSNA 208 GRAND CARAVAN Use the parts listing below to indentify all parts.

## WARNING

***Please be aware that this aeroplane is not a toy and if assembled or used incorrectly it is capable of causing injury to people or property. WHEN YOU FLY THIS AEROPLANE YOU ASSUME ALL RISK & REponsibility.***

If you are inexperienced with basic R/C flight we strongly recommend you contact your R/C supplier and join your local R/C model Flying Club. R/C Model Flying Clubs offer a variety of training procedures designed to help the new pilot on his way to successful R/C flight. They will also be able to advise on any insurance and safety regulations that may apply.

## KIT CONTENTS

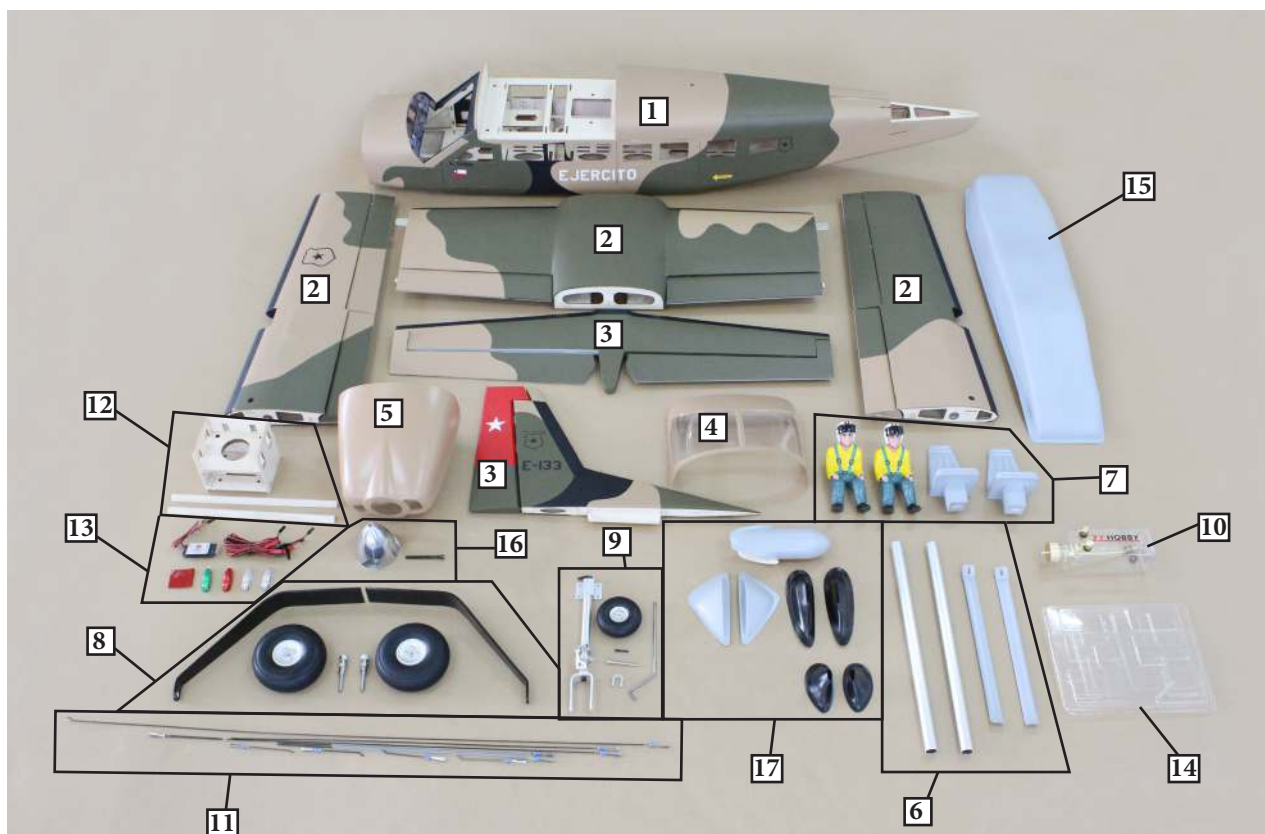

## KIT CONTENTS

SEA362 CESSNA 208 GRAND CARAVAN  
85 INCH WINGSPAN 35-40cc

1. Fuselage
2. Wing set (3)
3. Tail set (2)
4. Canopy
5. Cowling
6. Wing tube
7. Cockpit and Pilot
8. Landing gear
9. Nose gear
10. Fuel tank
11. Pushrod set
12. Ep Motor box
13. Led light set
14. Windows
15. Cargo Pod
16. Spinner
17. Fiberglassed covers set

## ADDITIONAL ITEMS REQUIRED

- 35-40cc gasoline engine.
- Computer radio 8 channel with 9 servos.
- Glow plug to suit engine.
- Propeller to suit engine.
- Protective foam rubber for radio system.

## TOOLS & SUPPLIES NEEDED

- Thin cyanoacrylate glue.
- Medium cyanoacrylate glue.
- 30 minute epoxy.
- 5 minute epoxy.
- Hand or electric drill.
- Assorted drill bits.
- Modelling knife.
- Straight edge ruler.
- 2mm ball driver.
- Phillips head screwdriver.
- 220 grit sandpaper.
- 90° square or builder's triangle.
- Wire cutters.
- Masking tape & T-pins.
- Thread-lock.
- Paper towels.

## LED LIGHT SET

Please see pictures below.

1.

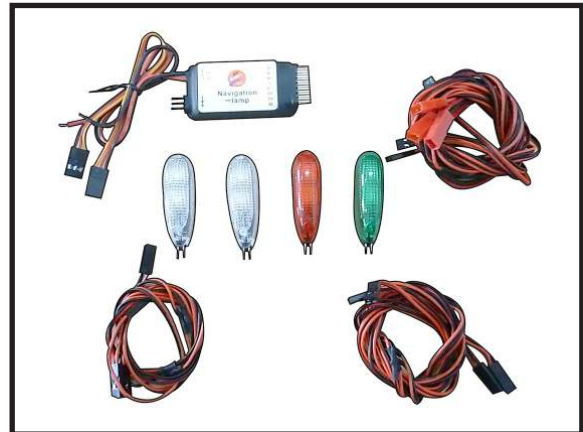

One white light and one green light for the right wing tip, one white light and one red light for the left wing tip.

2.

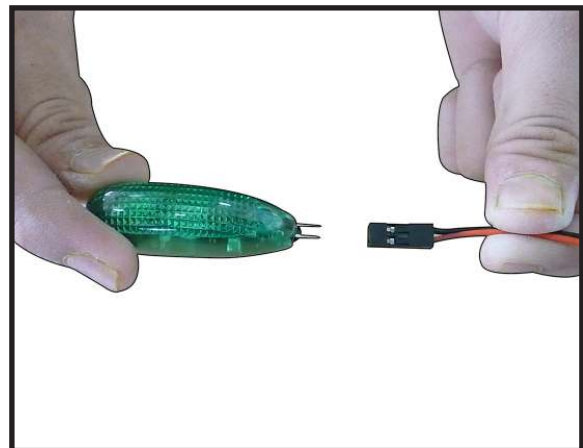

3.

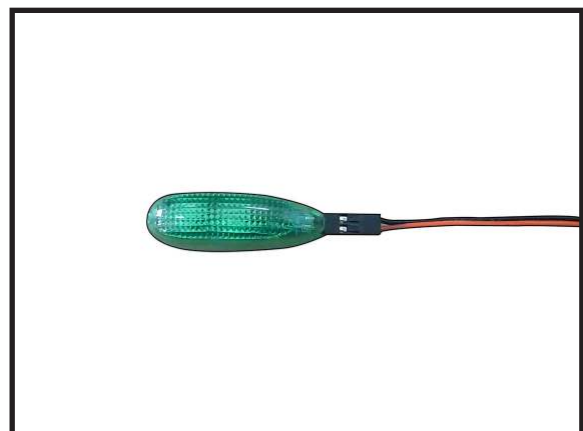



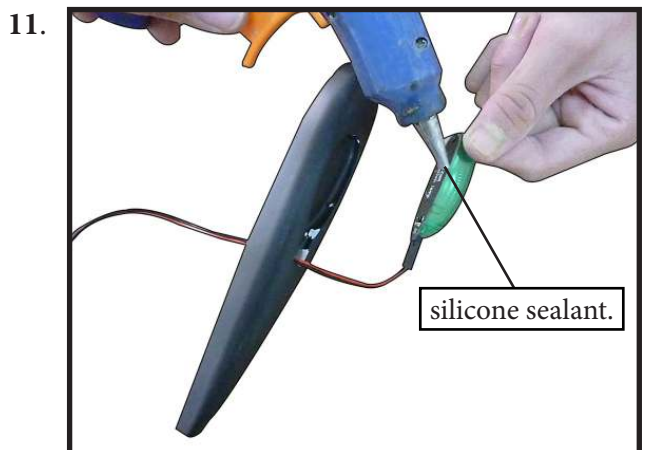
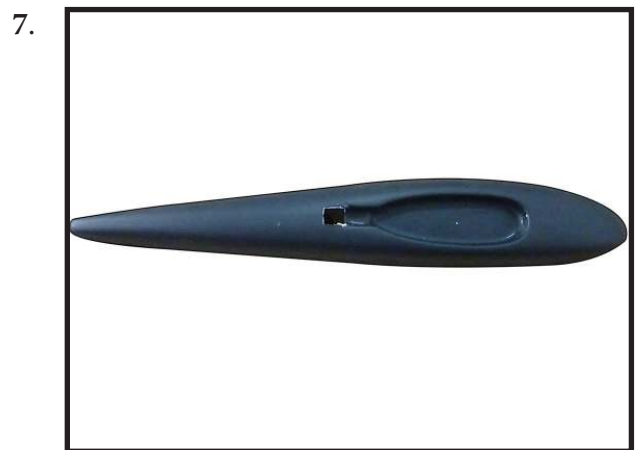
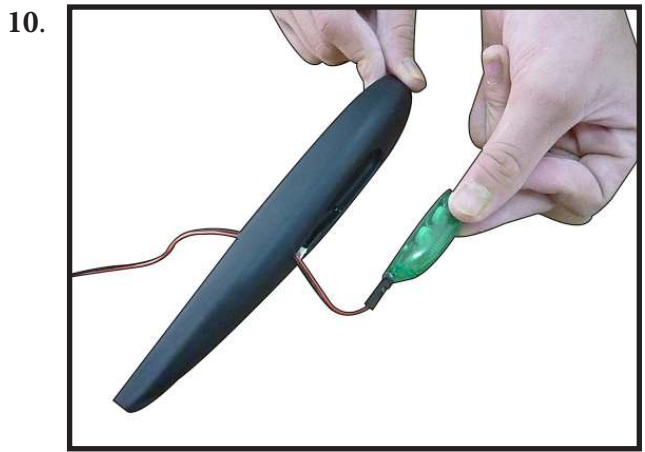
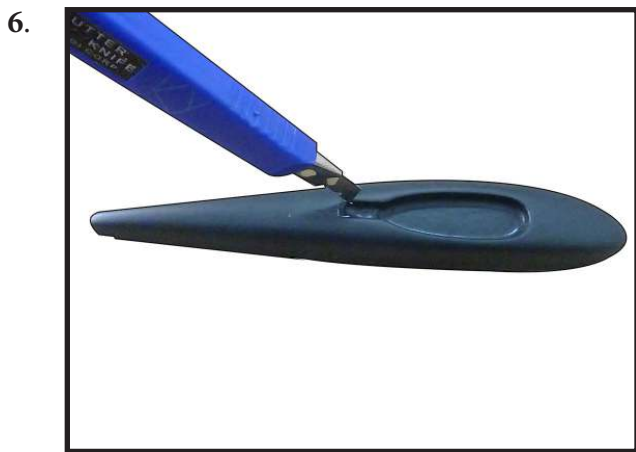
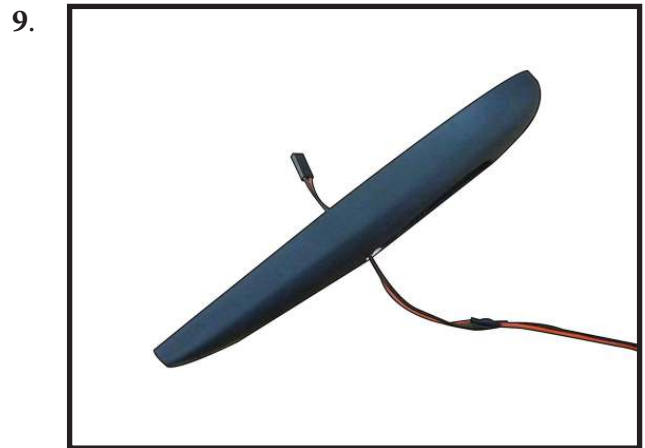
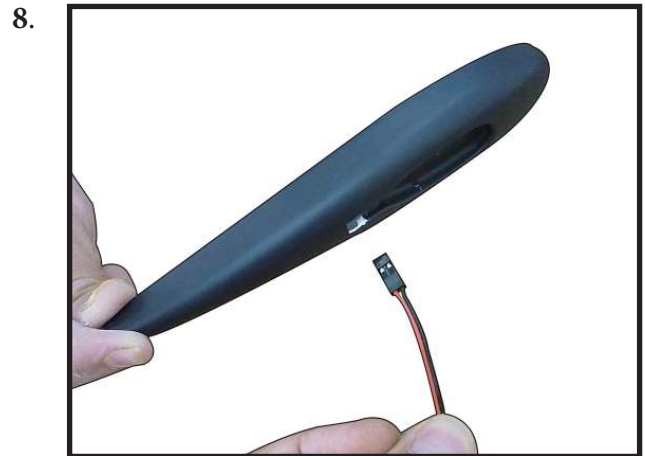
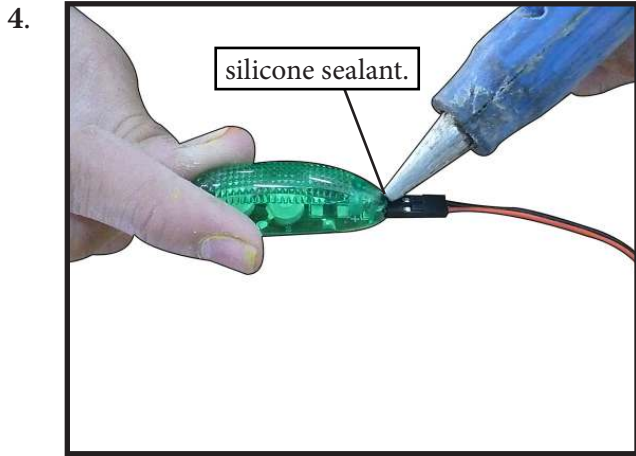

12.

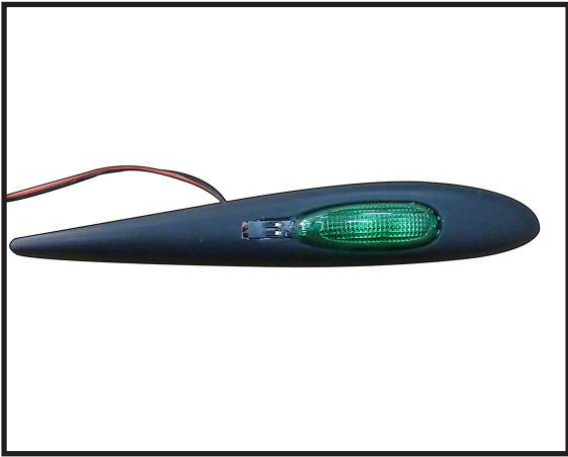

16.

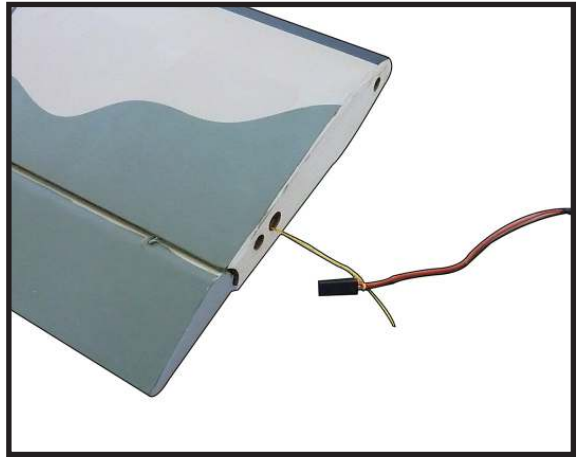

13.



17.

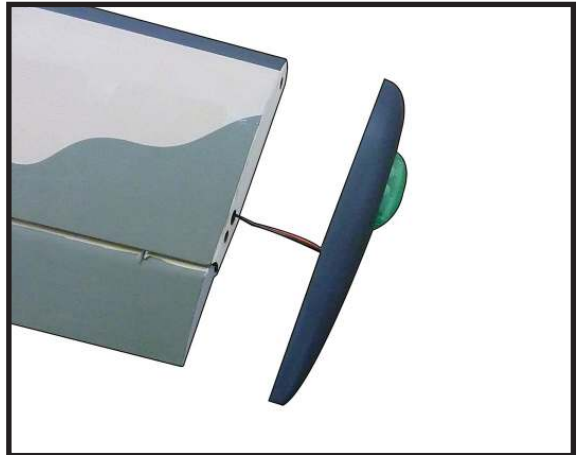

14.

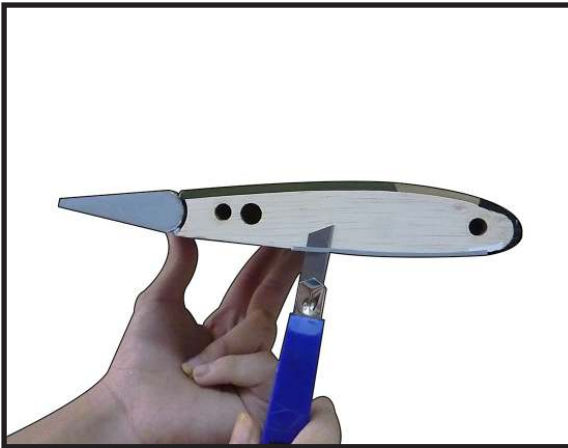

18.



15.

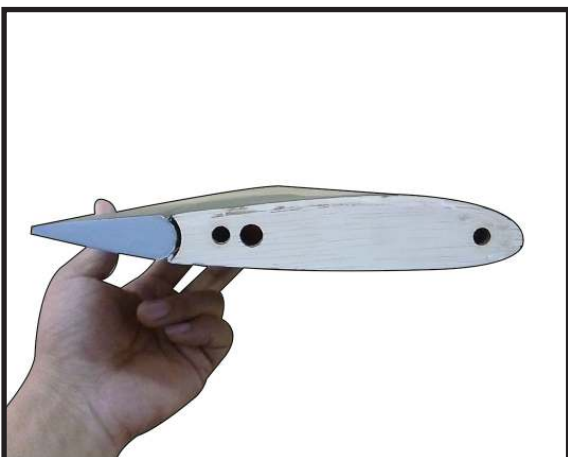

19.

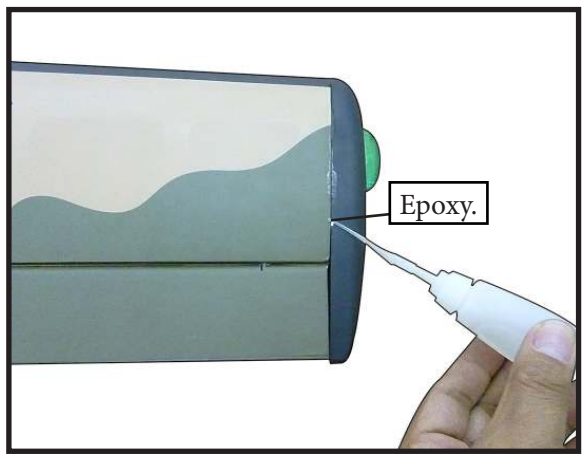

20.

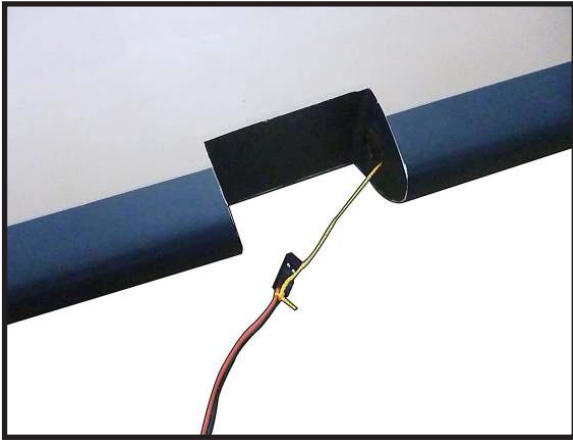

24.

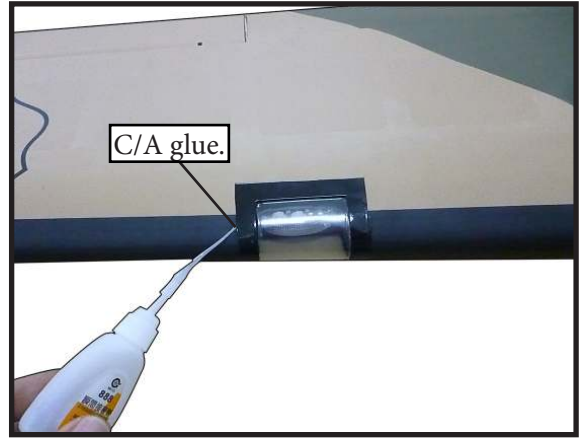

21.

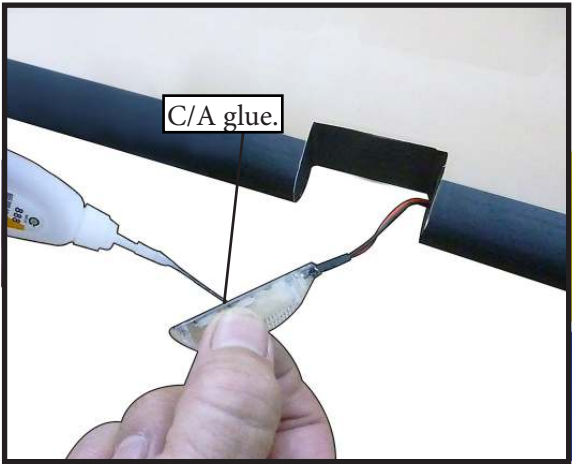

25.



22.



26.



23.



27.



## INSTALL THE AILERONS CONTROL HORN

1.

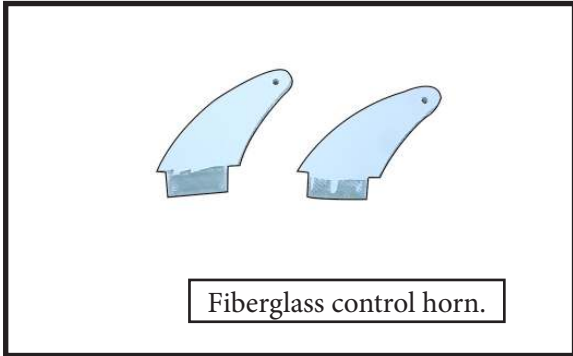

2.

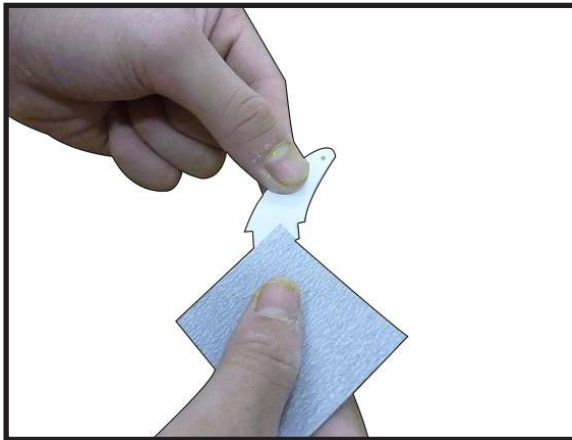

3.

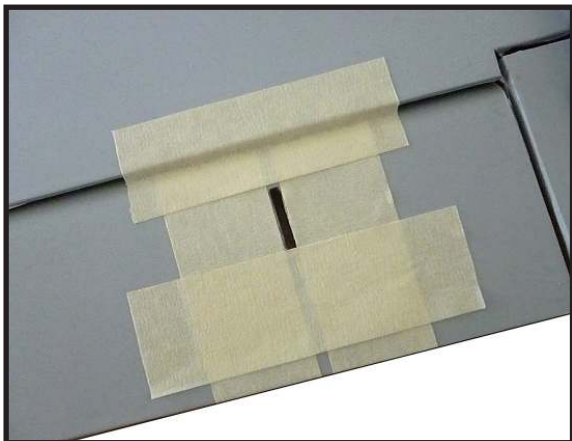

4.

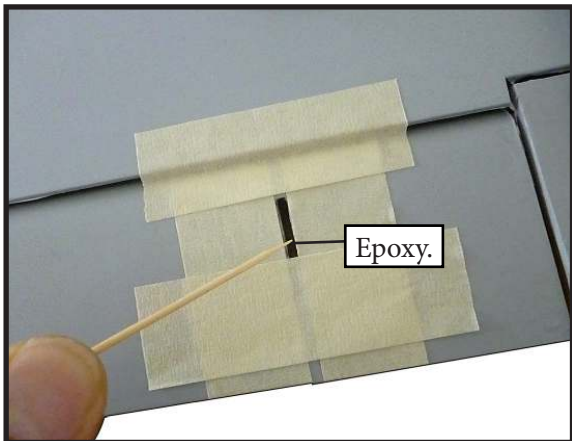

5.

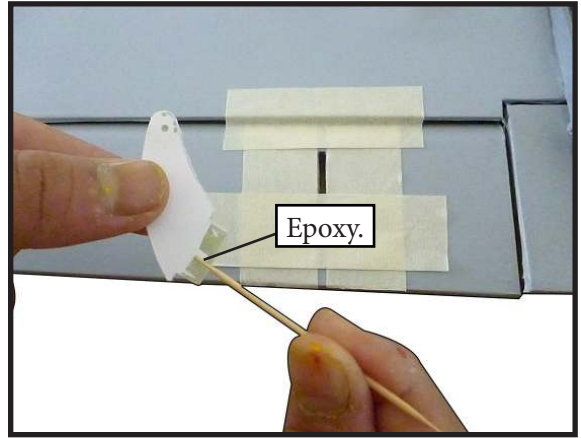

6.

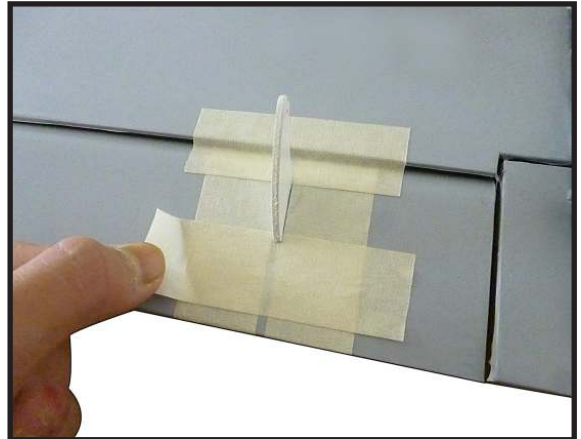

7.

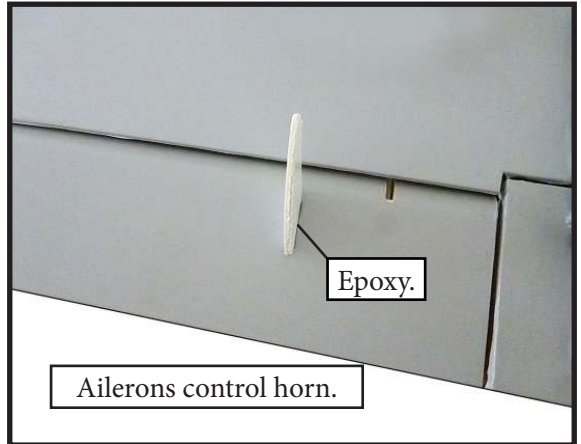



**INSTALLING THE AILERON SERVOS**

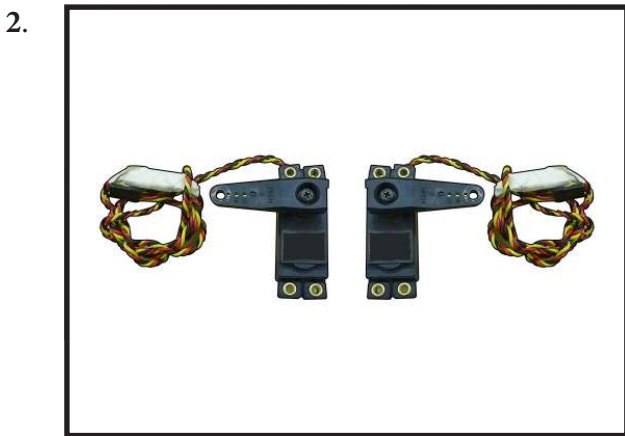
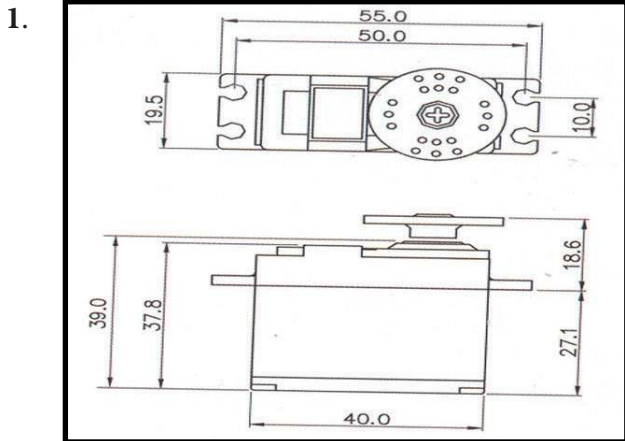

**Minimum servo spec.**  
**Torque :** 115.3 oz-in (8.3 kg-cm) @ 4.8V;  
 157.8 oz-in (11.3 kg-cm) @ 6.0V  
 180.1 oz-in (12.9 kg) @ 7.4V

Because the size of servos differ, you may need to adjust the size of the precut opening in the mount. The notch in the sides of the mount allow the servo lead to pass through.

Use dental floss or heatshrink tube to secure the connection so they cannot become unplugged.

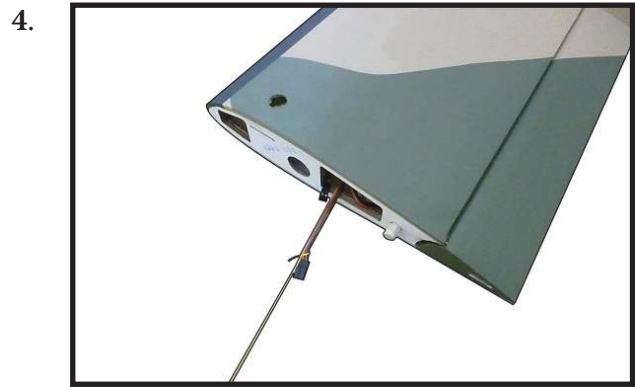
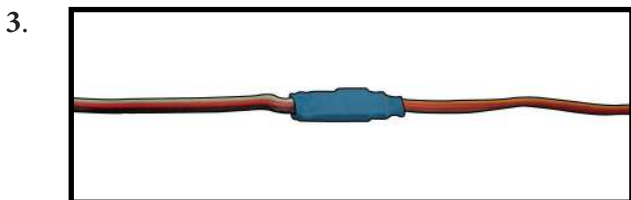

Set the aileron hatch in place and use a Phillips screw driver to install it with four wood screws.

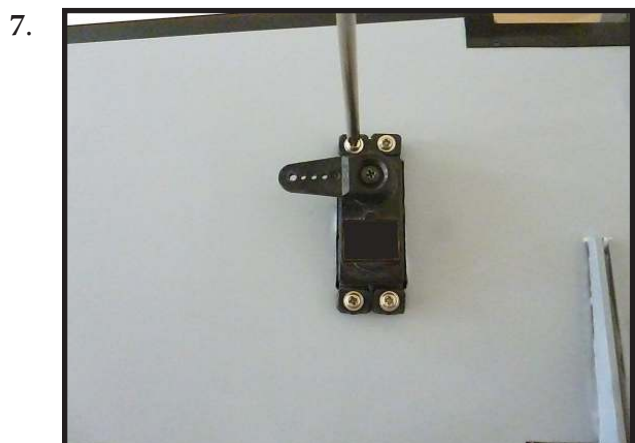



8.

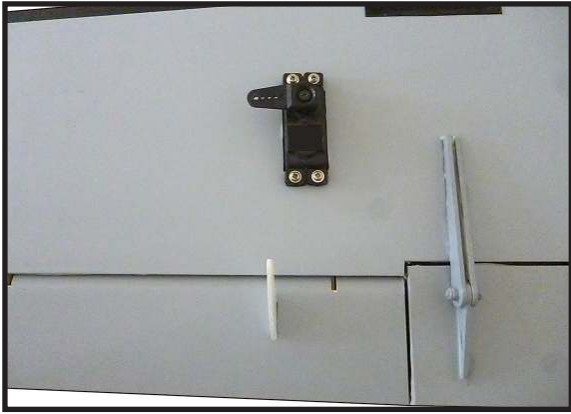

**AILERON PUSHROD INSTALLATION**

1.

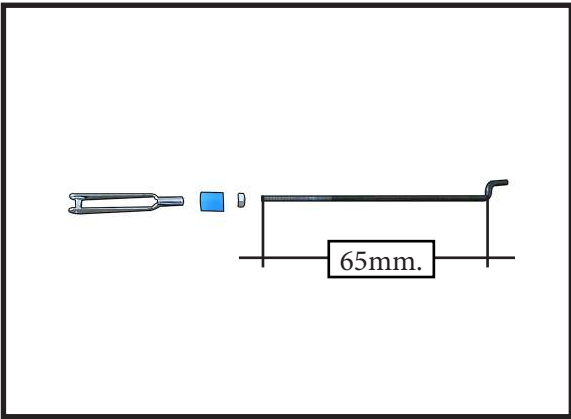

2.

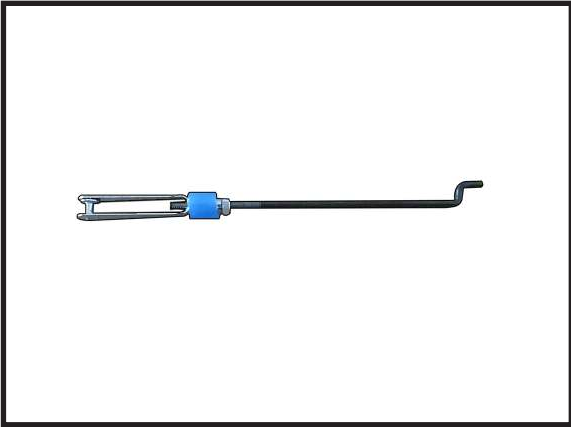

3.

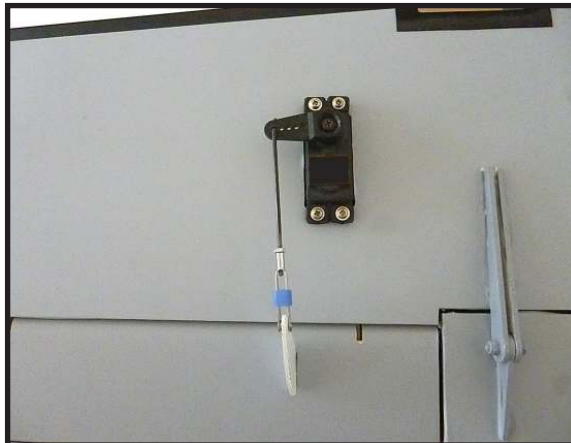

**INSTALL FLAP CONTROL HORN**

1.

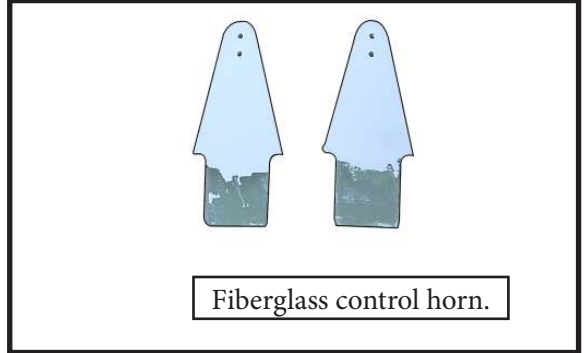

2.

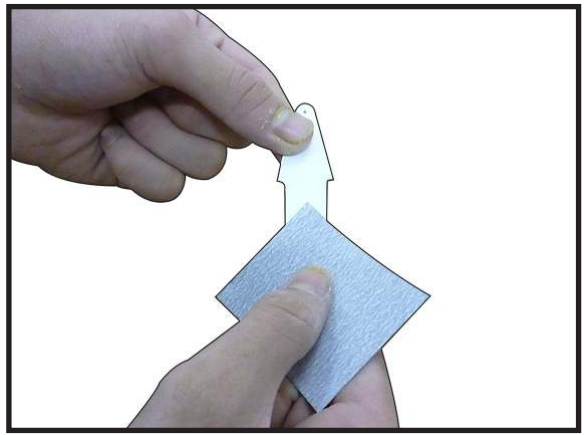

3.

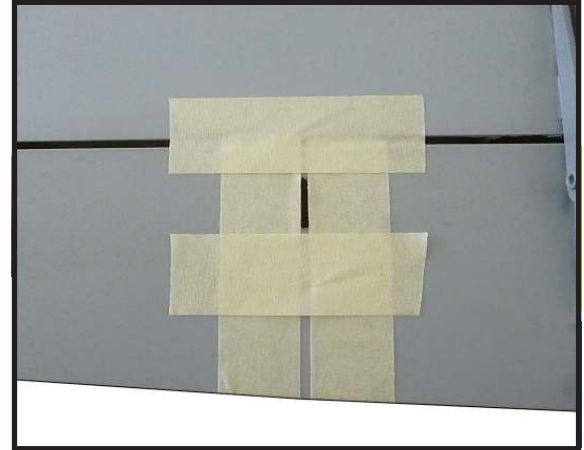

4.

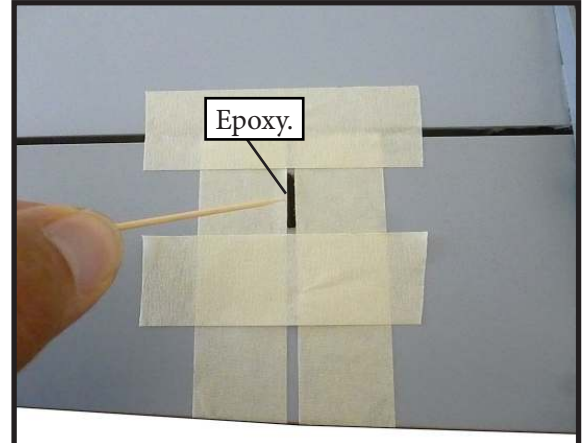

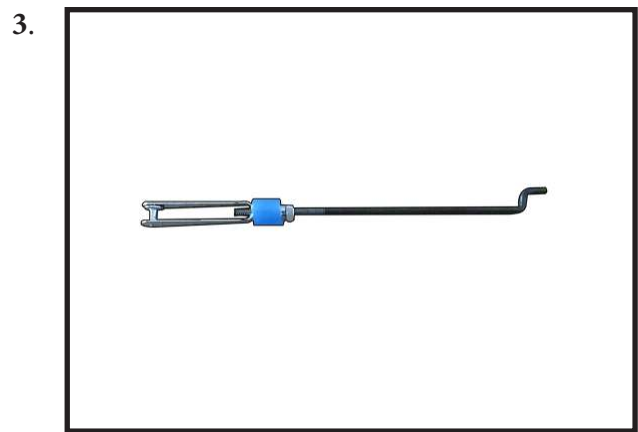
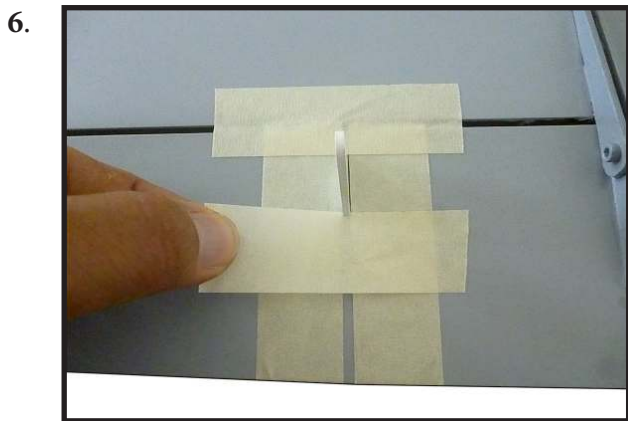
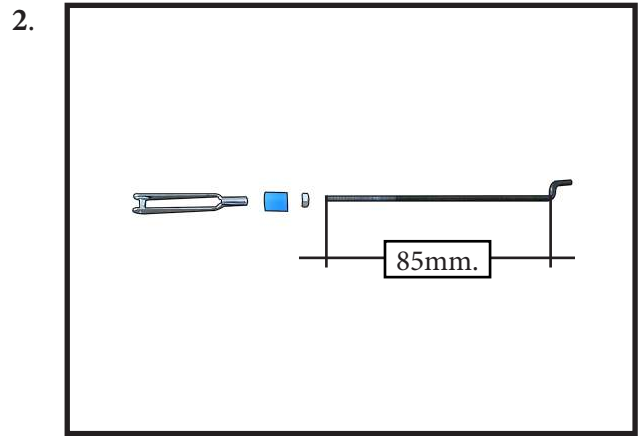
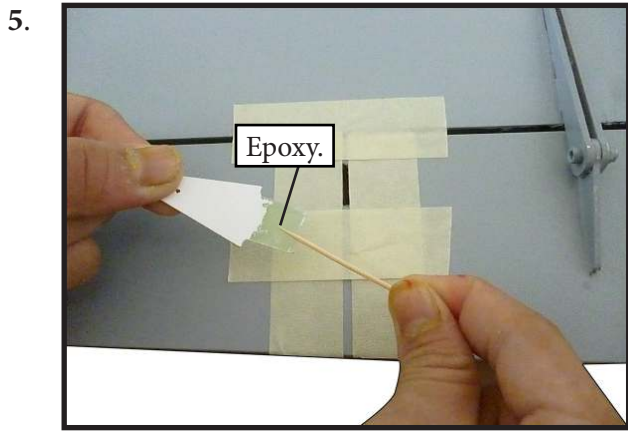

**INSTALLING THE FLAP PUSHROD**

Please see below pictures.

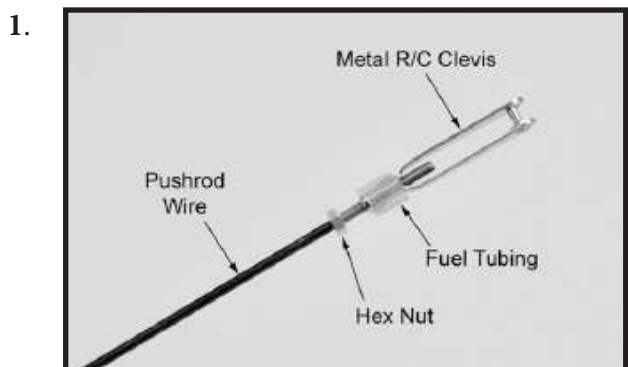

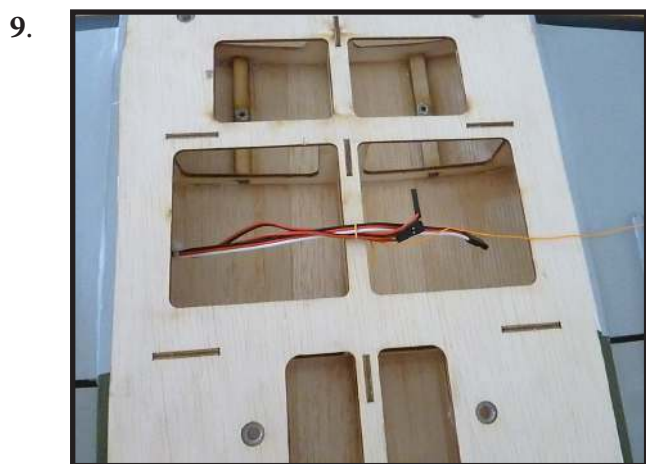
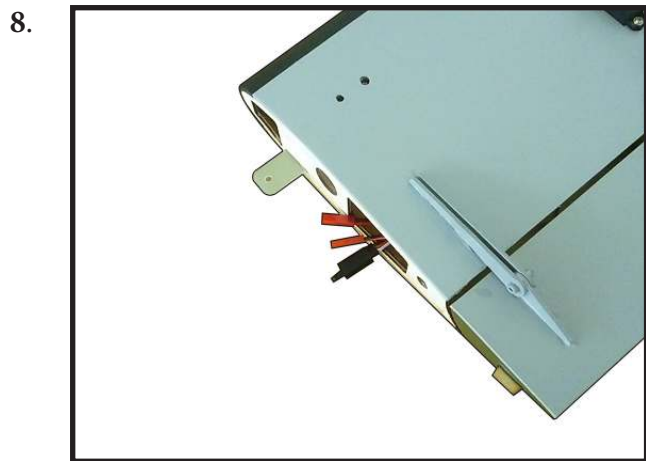

## LANDING GEAR INSTALLATION

Locate items needed for landing gear installation.

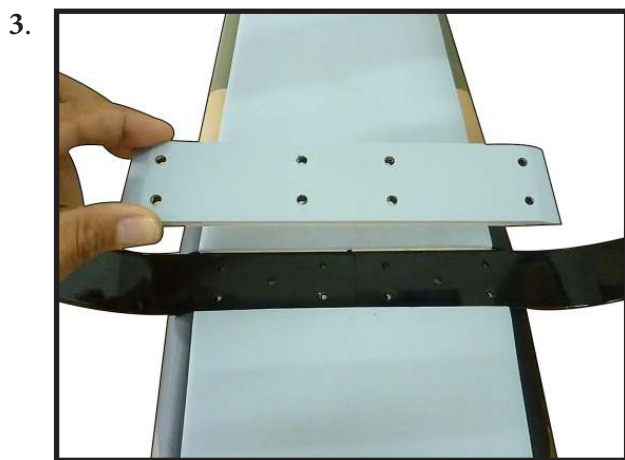
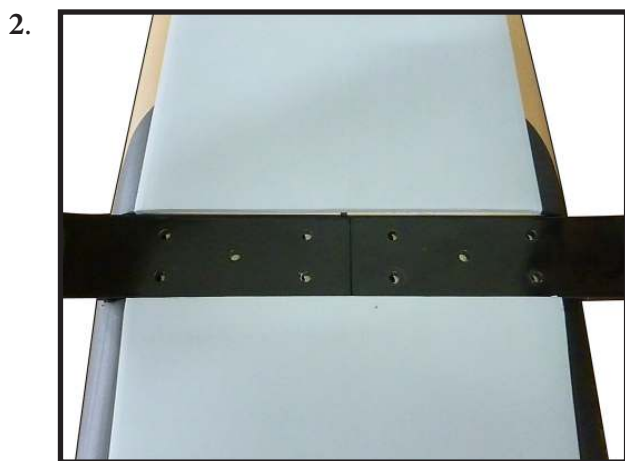
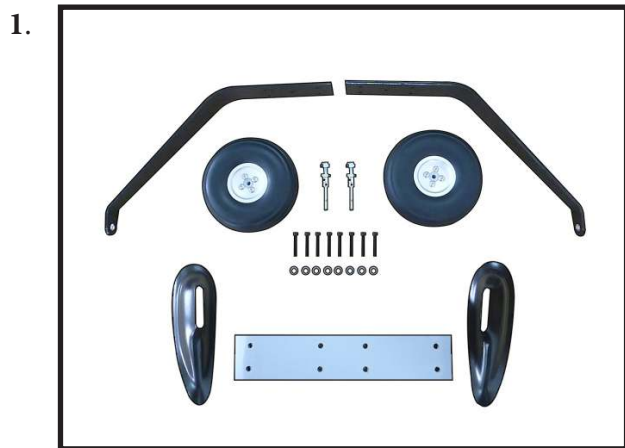

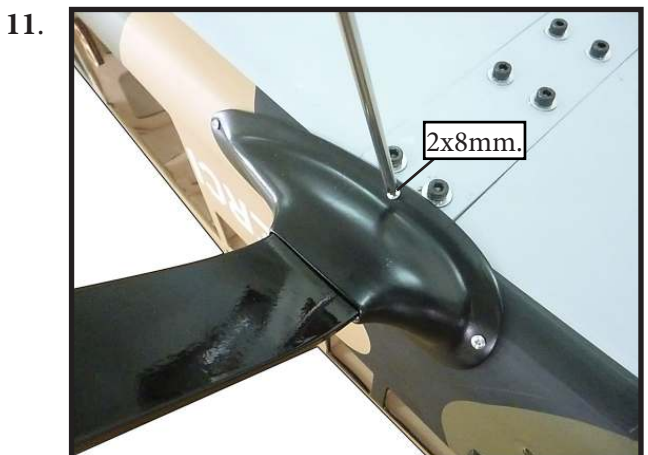
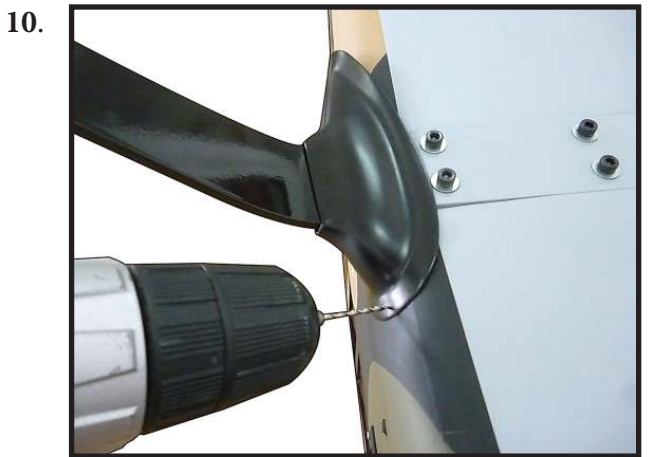
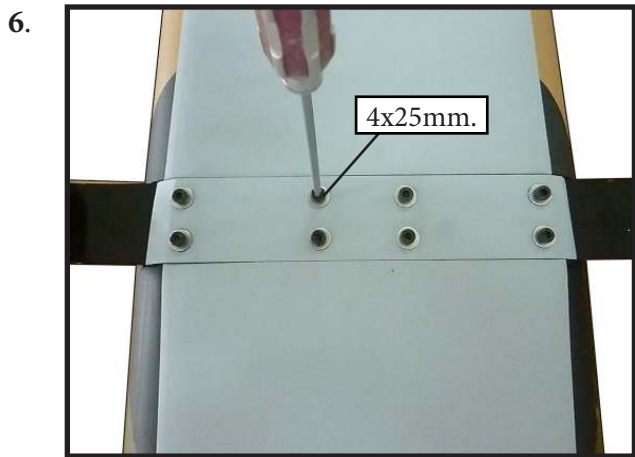
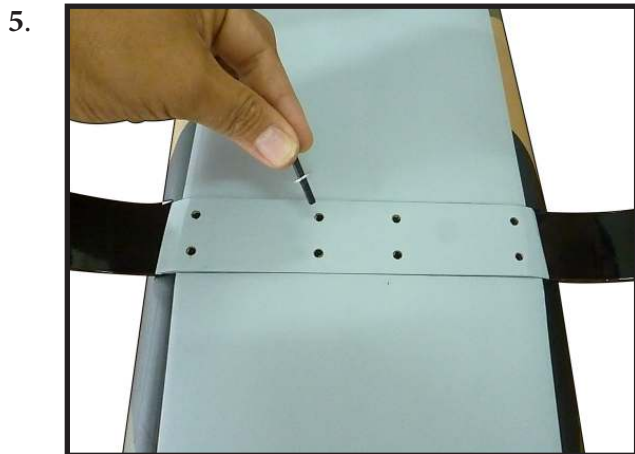
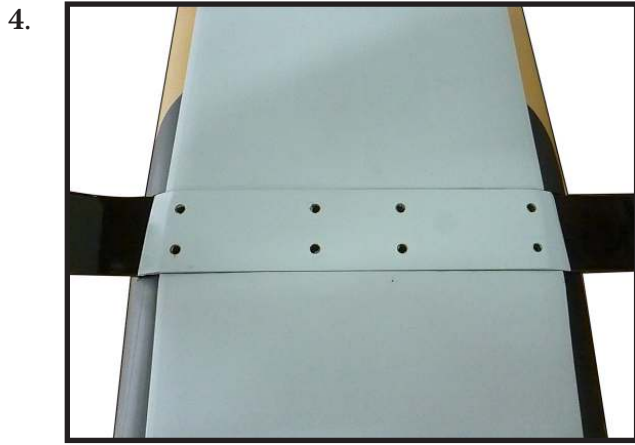



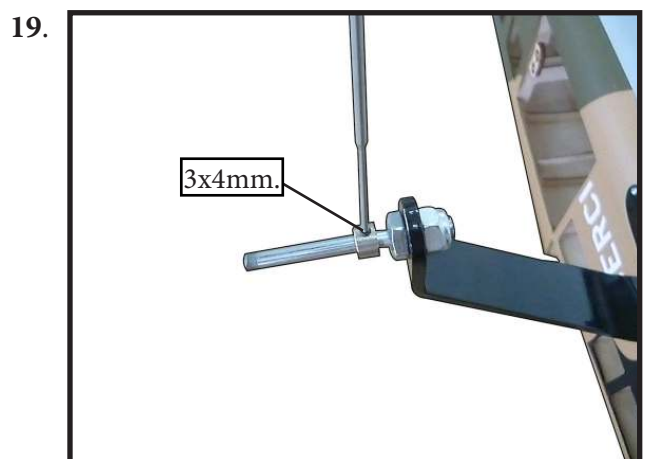
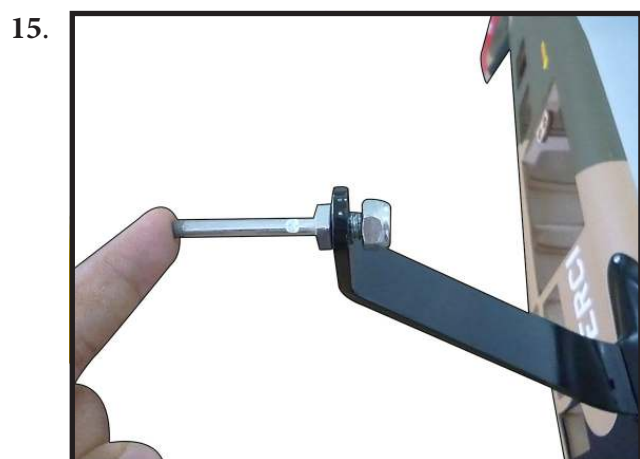
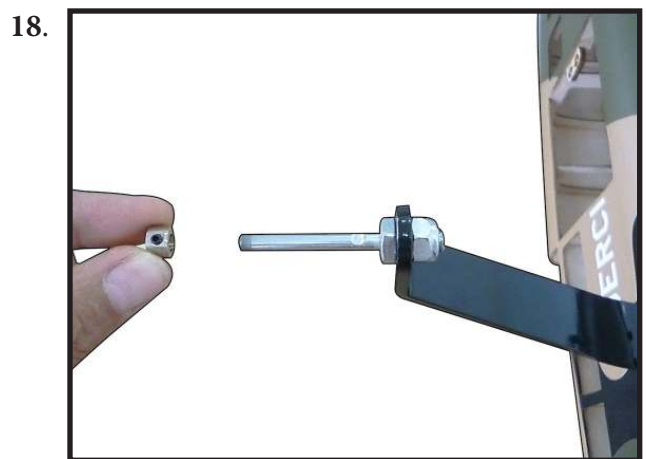
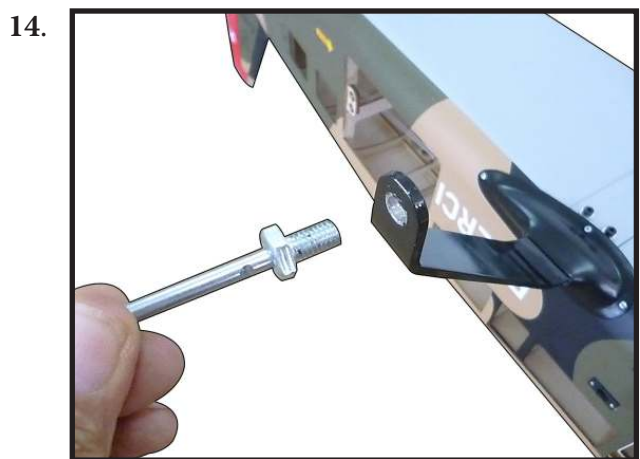
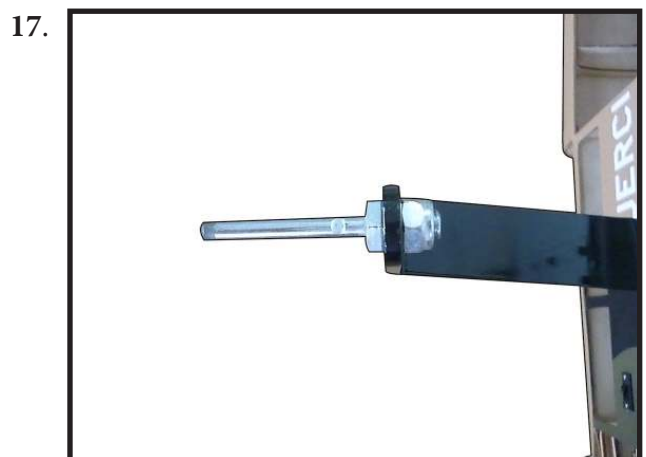
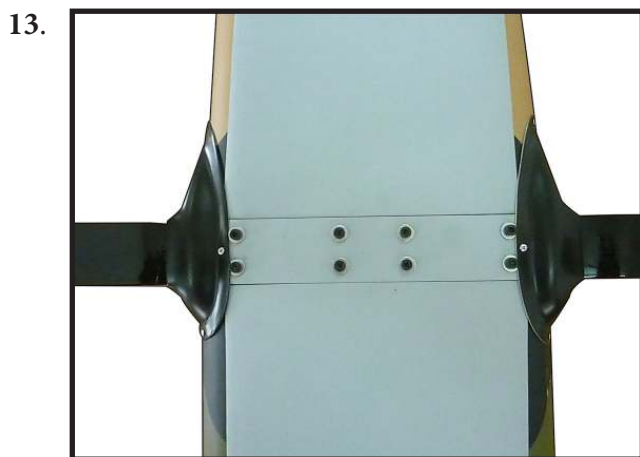

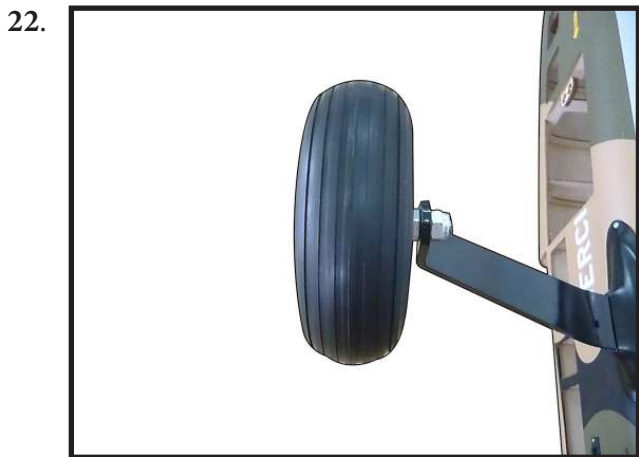
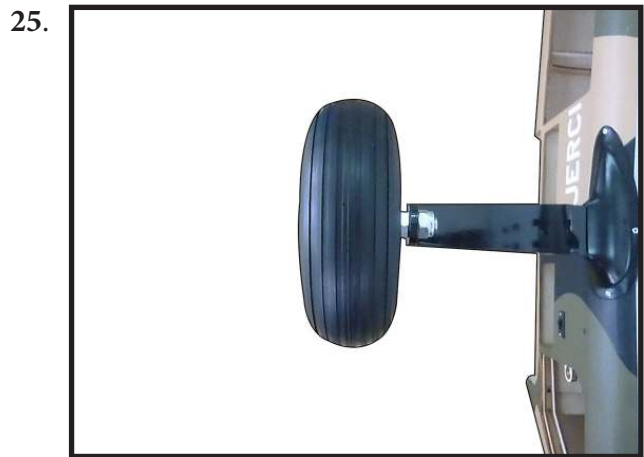
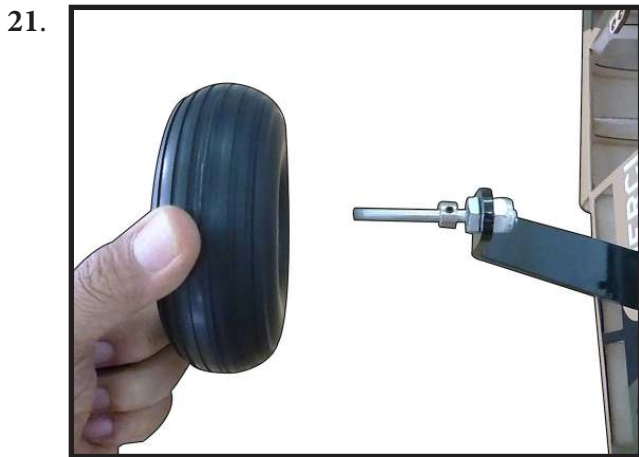
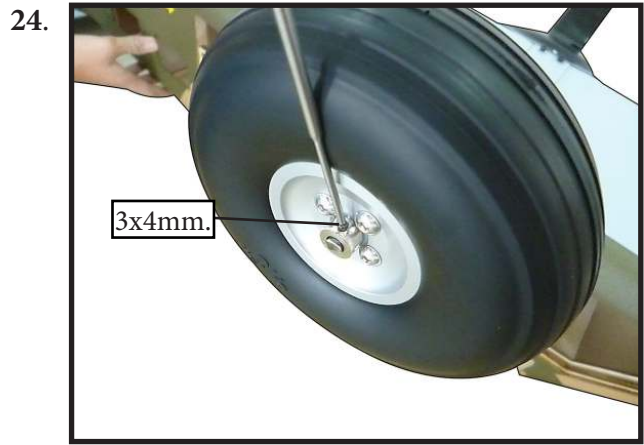
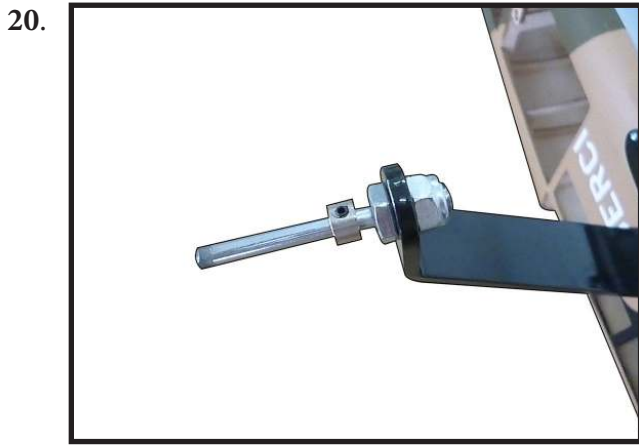

**NOSE GEAR INSTALLATION**

Locate the parts needed to attach the nose gear.

1.

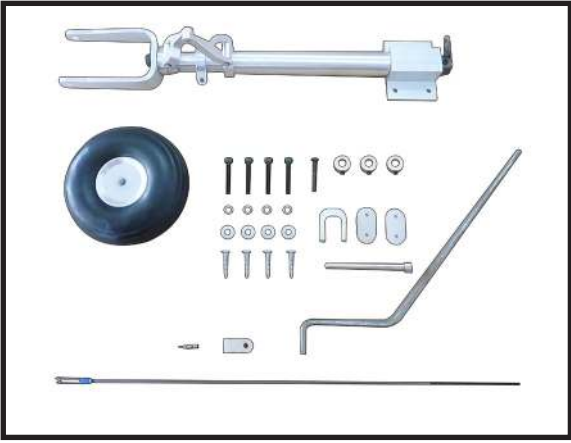

5.



2.

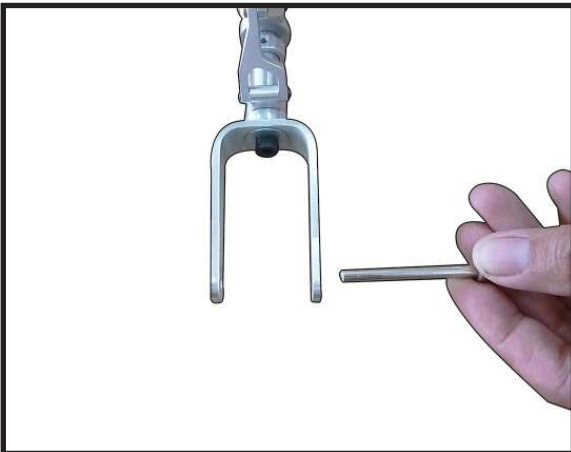

6.

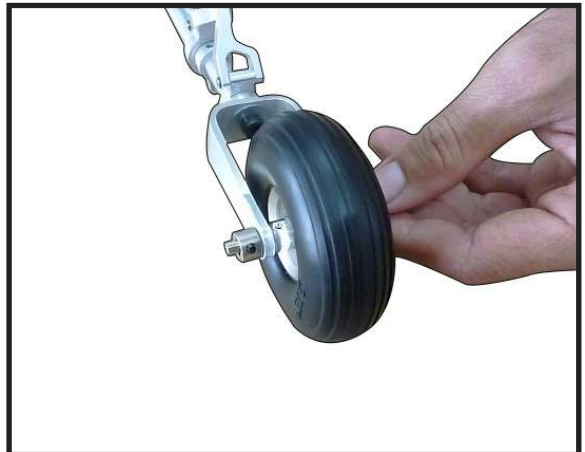

3.



7.

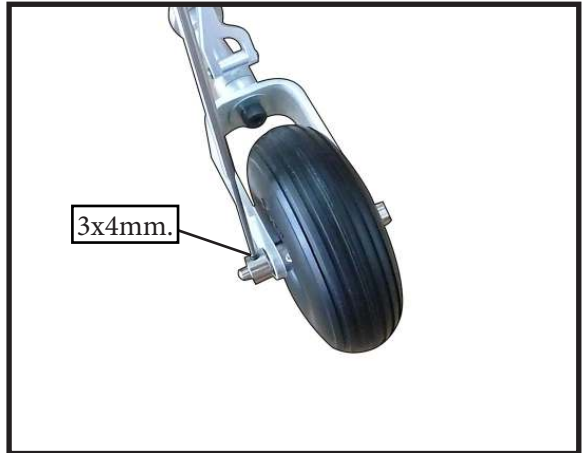

4.

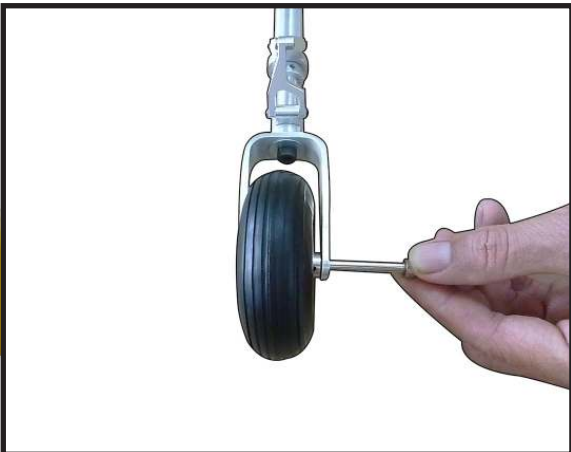

8.

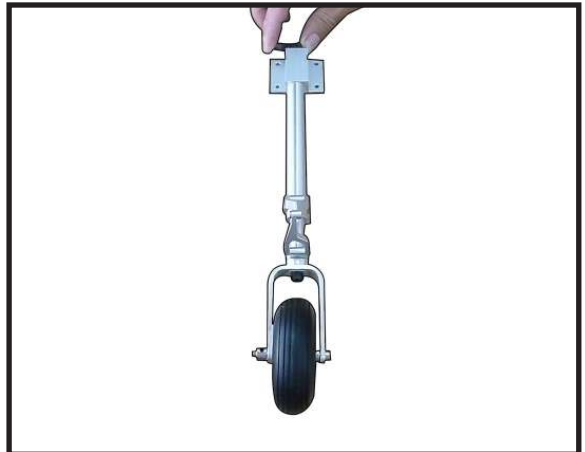

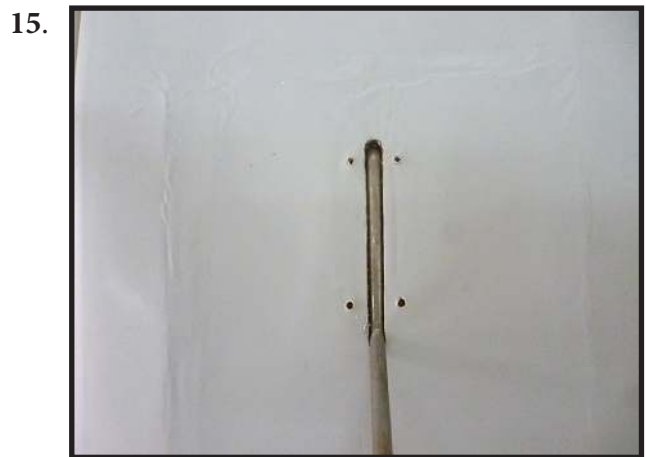
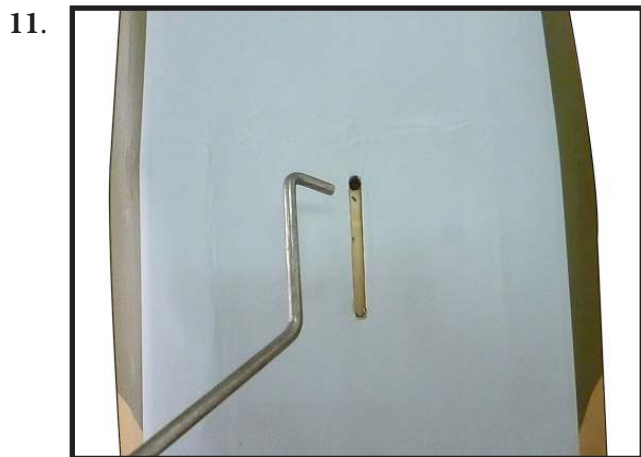
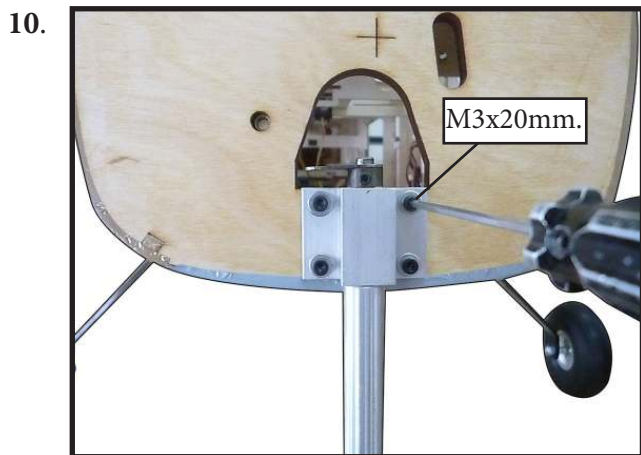
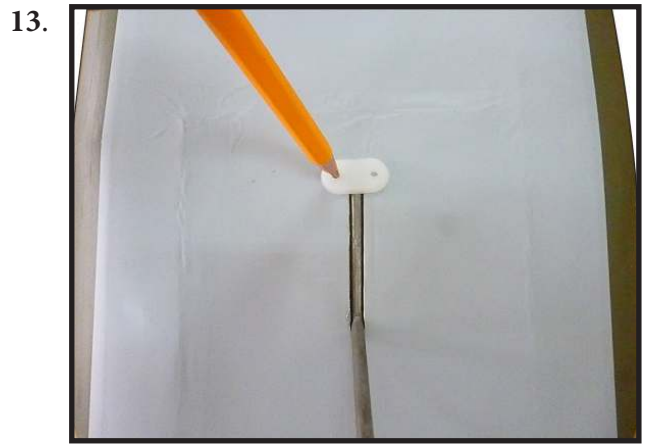



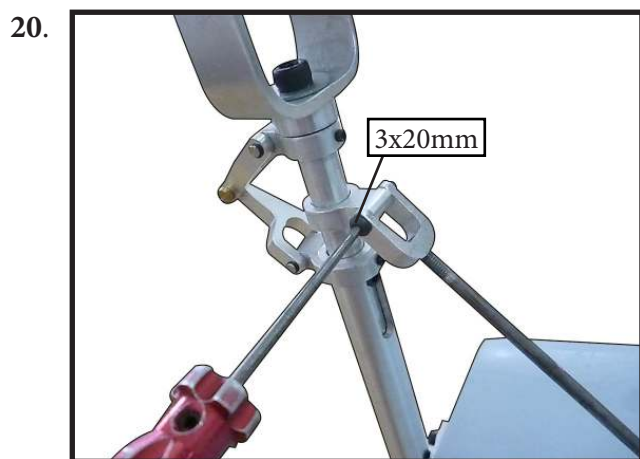
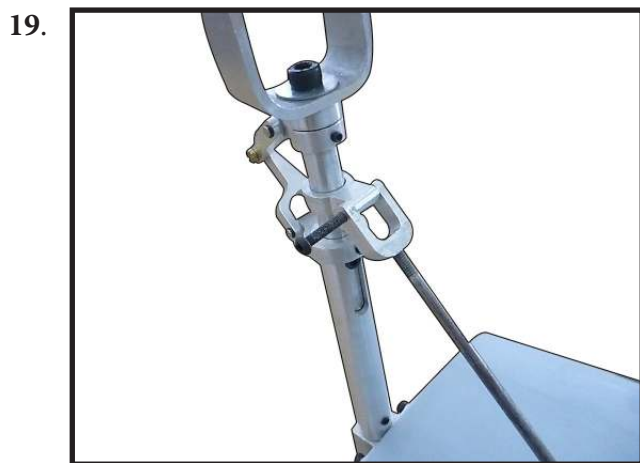
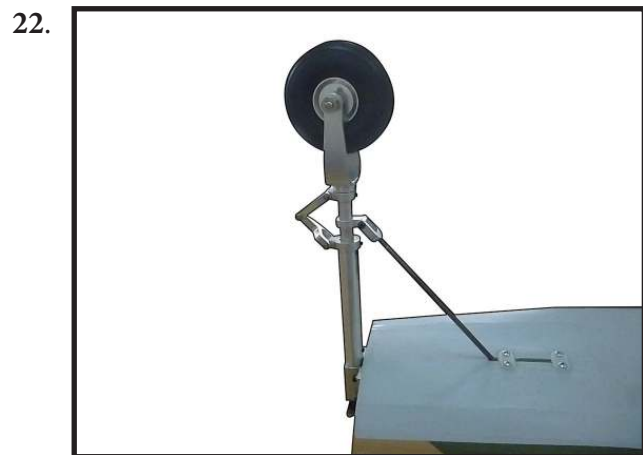
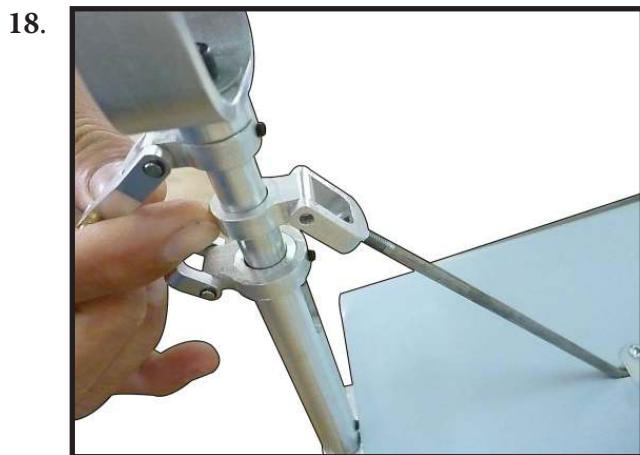
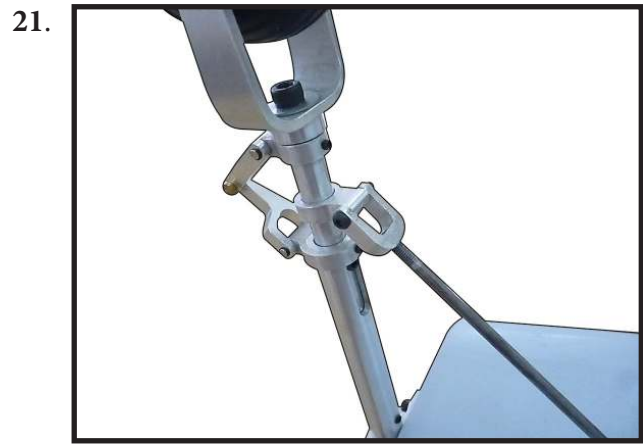

25.

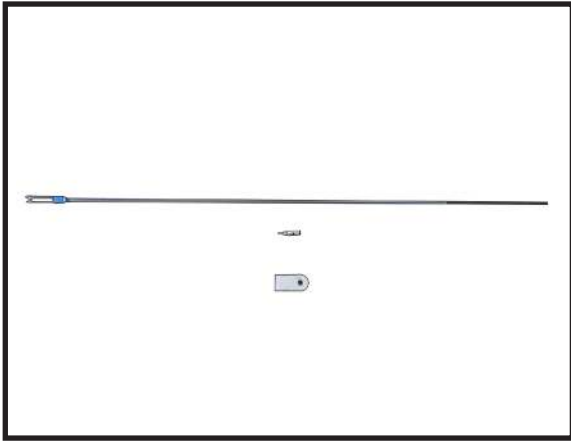

29.

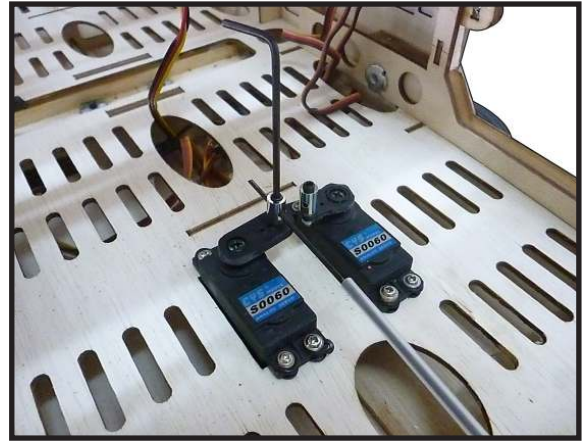

26.



30.

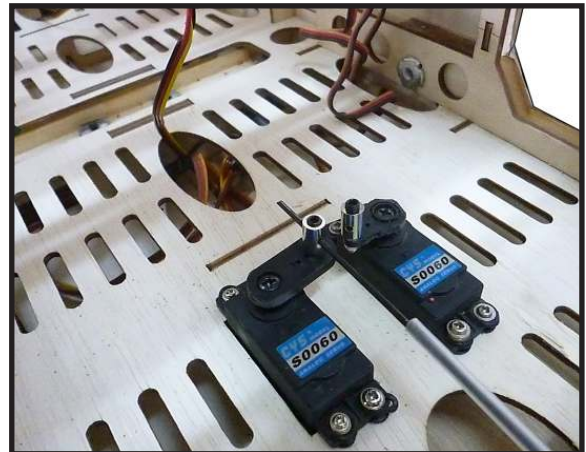

27.



**INSTALLING THE RECEIVER SWITCH**

Install the switch into the precut hole in the side, of the fuselage.

1.

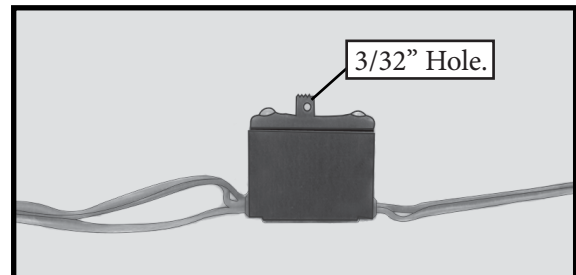

28.



2.



3.

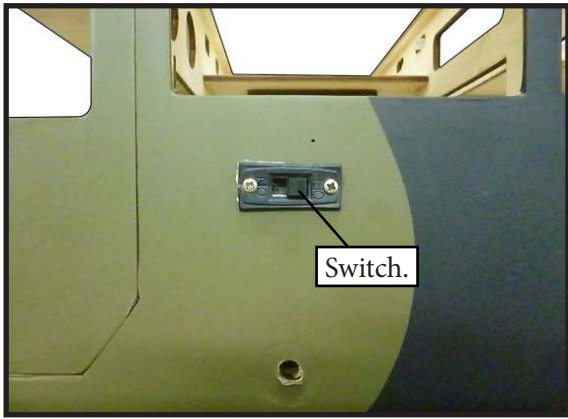

**INSTALLING THE ENGINE SWITCH**

1.

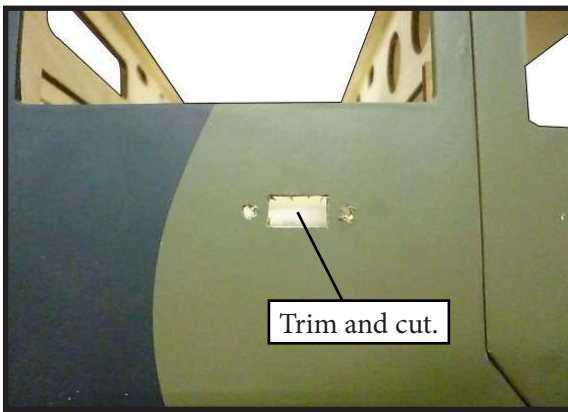

2.

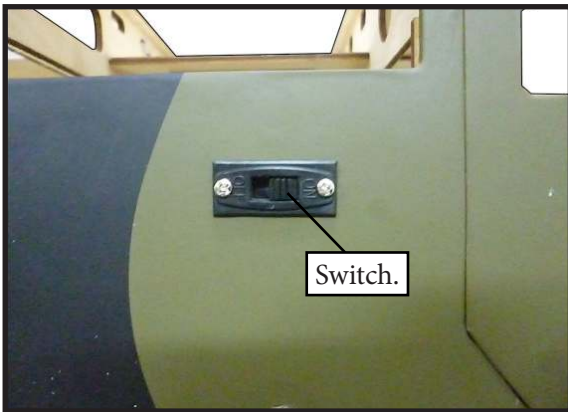

**INSTALLING THE STOPPER ASSEMBLY**

Using a modeling knife, carefully cut off the rear portion of one of the 3 nylon tubes leaving 1/2" protruding from the rear of the stopper. This will be the fuel pick up tube.

Using a modeling knife, cut one length of silicone fuel line. Connect one end of the line to the weighted fuel pick up and the other end to the nylon pick up tube.

1.

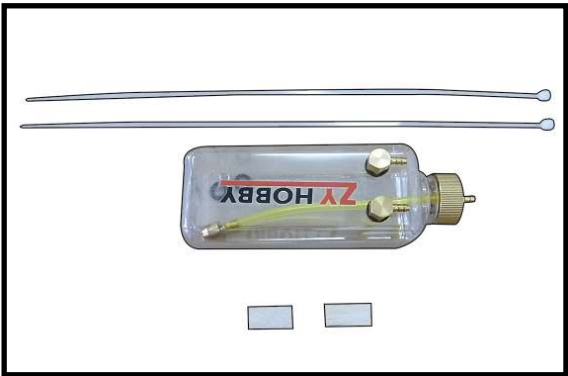

Carefully bend the second nylon tube up at a 45° angle. This tube is the vent tube.

Test fit the stopper assembly into the tank. It may be necessary to remove some of the flashing around the tank opening using a modeling knife. If flashing is present, make sure none falls into the tank.

With the stopper assembly in place, the weighted pick-up should rest away from the rear of the tank and move freely inside the tank. The top of the vent tube should rest just below the top of the tank. It should not touch the top of the tank.

When satisfied with the alignment of the stopper assembly tighten the 3 x 20mm machine screw until the rubber stopper expands and seals the tank opening. Do not over-tighten the assembly as this could cause the tank to split.

**FUEL TANK INSTALLATION**

1.

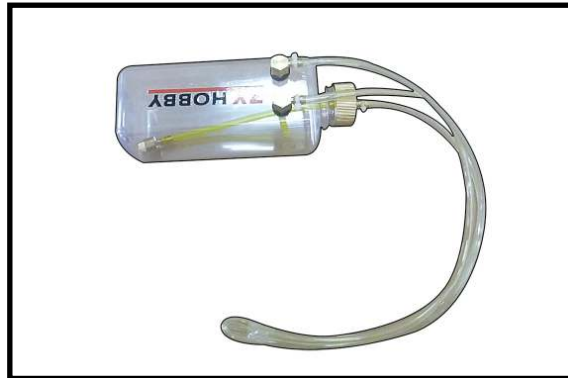

**!** *You should mark which tube is the vent and which is the fuel pickup when you attach fuel tubing to the tubes in the stopper. Once the tank is installed inside the fuselage, it may be difficult to determine which is which.*



**MOUNTING THE ENGINE**

Please see images below.

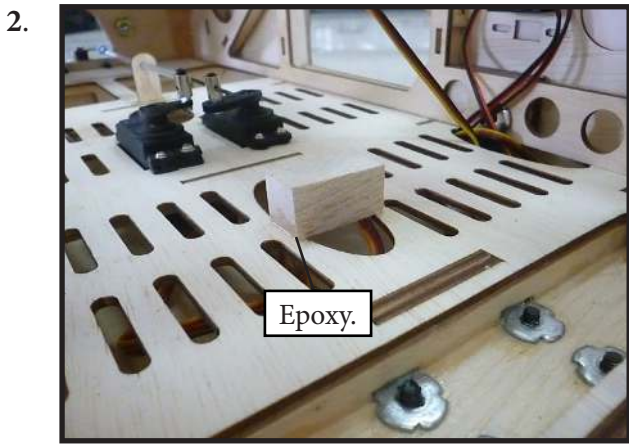
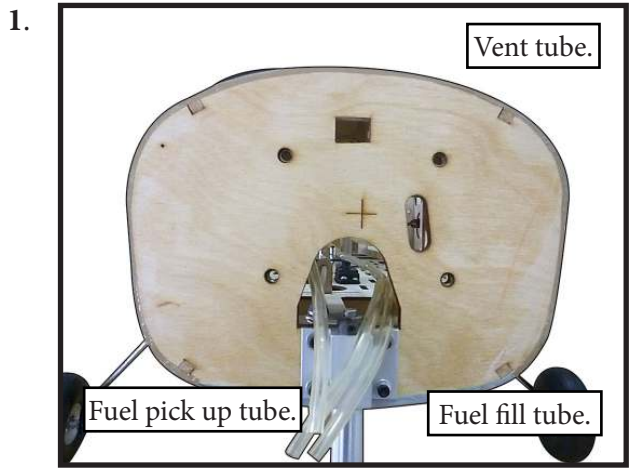

Connect the lines from the tank to the engine and muffler. The vent line will connect to the muffler and the line from the clunk to the carburetor.

-  *Blow through one of the lines to ensure the fuel lines have not become kinked inside the fuel tank compartment. Air should flow through easily.*

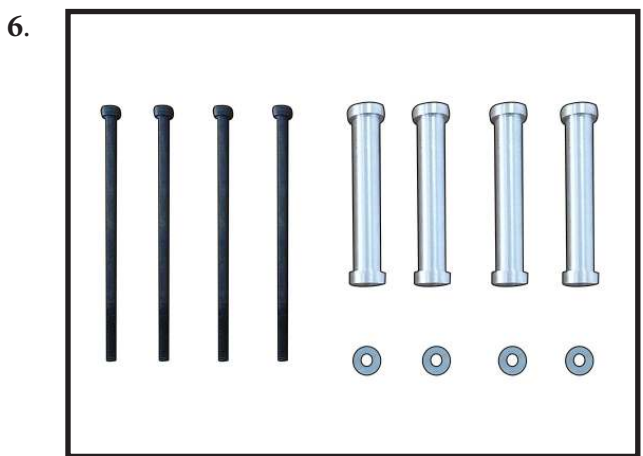



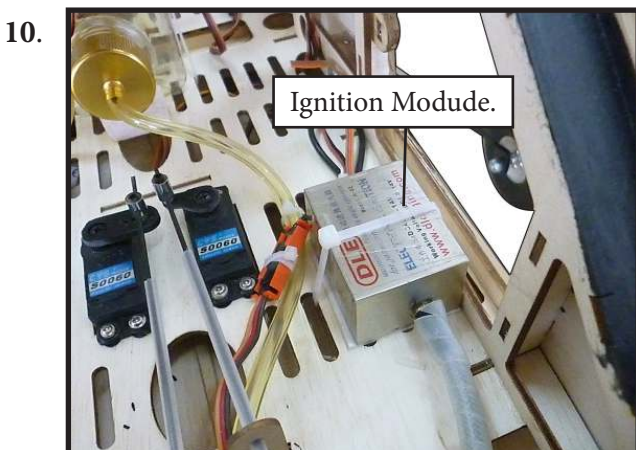
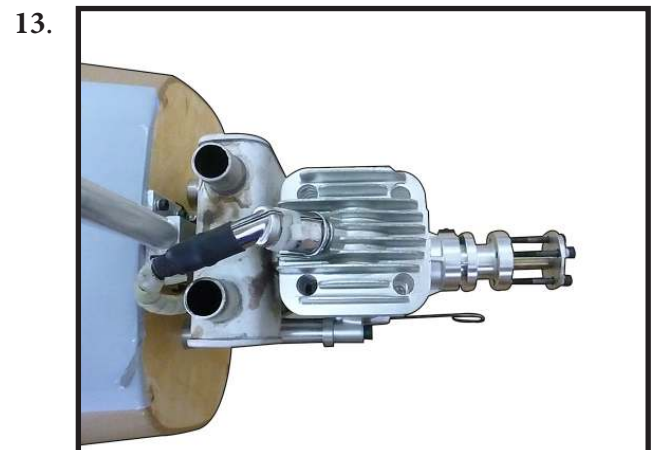
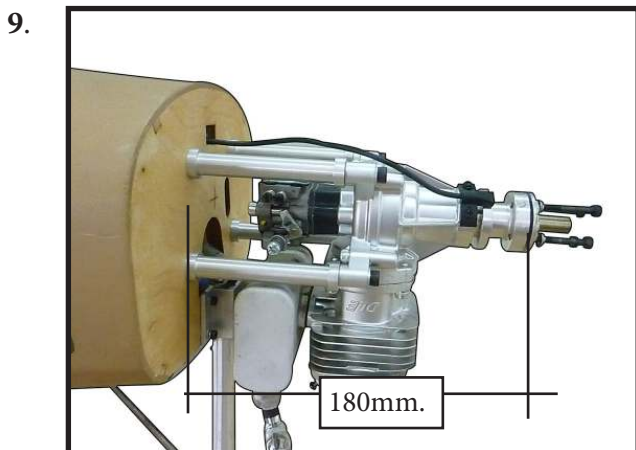
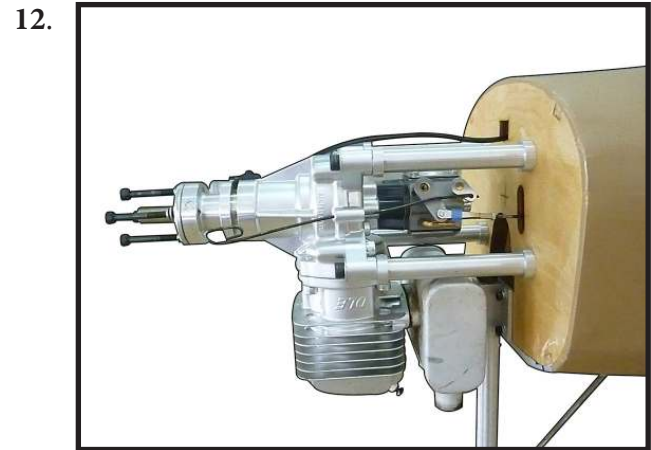
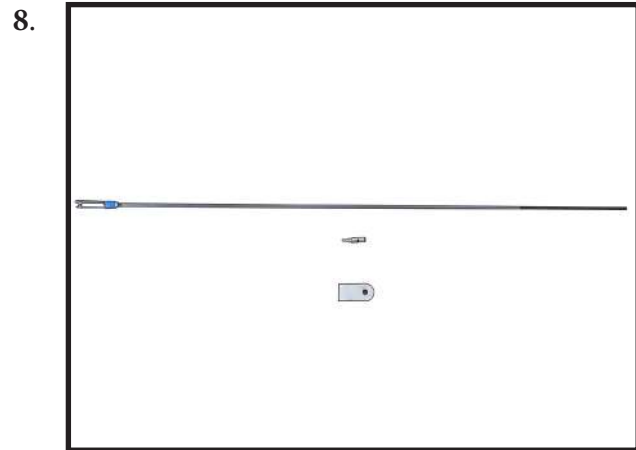
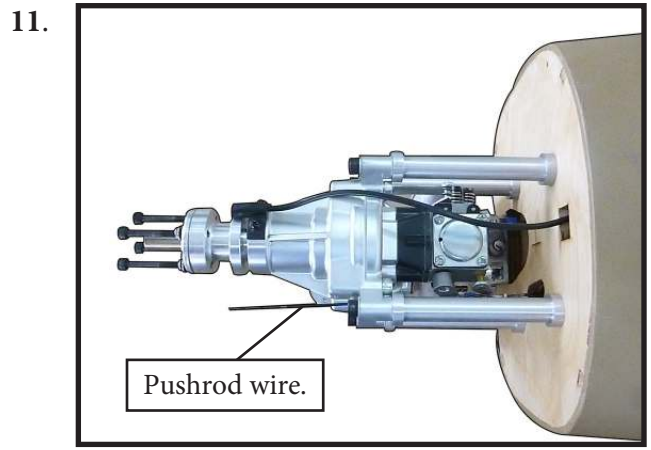
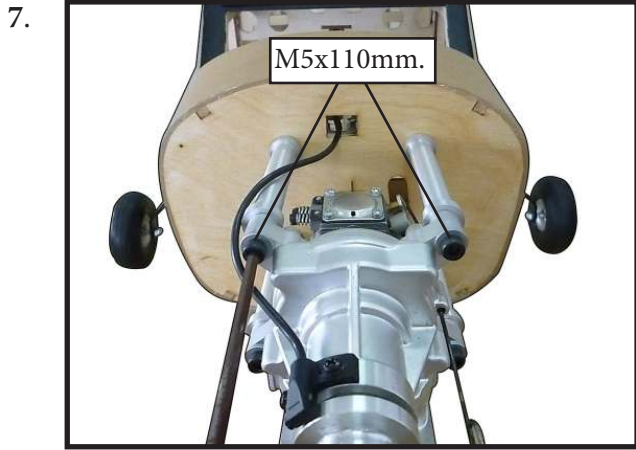

15.



Use medium CA to glue the pushrod standoff to the inside of the fuselage and the pushrod tube.

16.

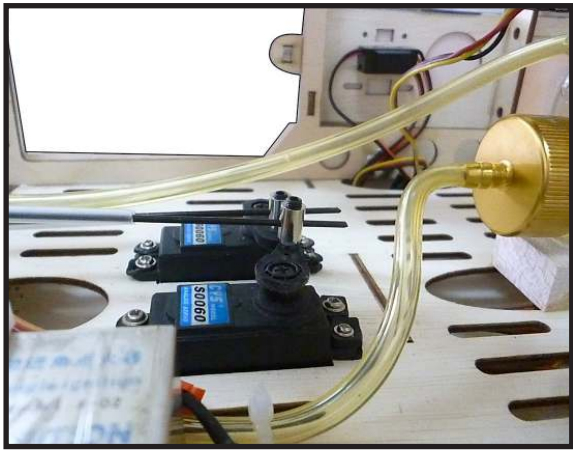

Reinstall the servo horn by sliding the connector over the pushrod wire. Center the throttle stick and trim and install the servo horn perpendicular to the servo center line.

17.



Move the throttle stick to the closed position and move the carburetor to closed. Use a 2.5mm hex wrench to tighten the screw that secures the throttle pushrod wire. Make sure to use threadlock on the screw so it does not vibrate loose.

## COWLING

Please see Images below:

1.



2.



3.





Tape the cowl to the fuselage using low-tack tape.

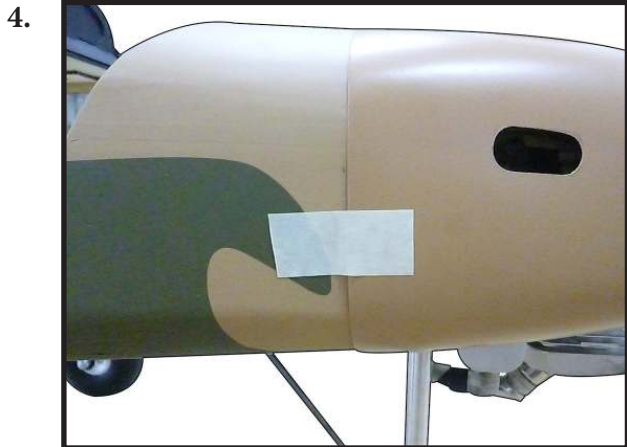

Use a drill and drill bit to drill the holes for the cowl mounting screws. Make sure the cowl position is correct before drilling each hole.

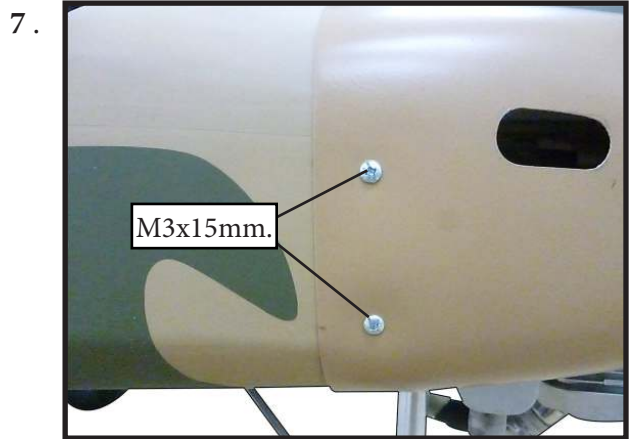
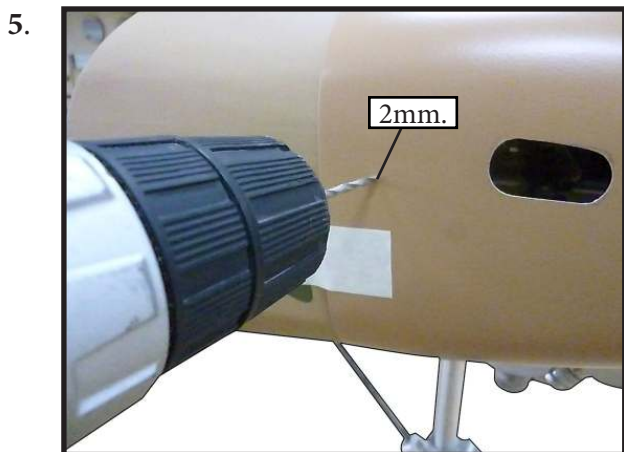

*Because of the size of the cowl, it may be necessary to use a needle valve extension for the high speed needle valve. Make this out of sufficient length 1.5mm wire and install it into the end of the needle valve. Secure the wire in place by tightening the set screw in the side of the needle valve.*

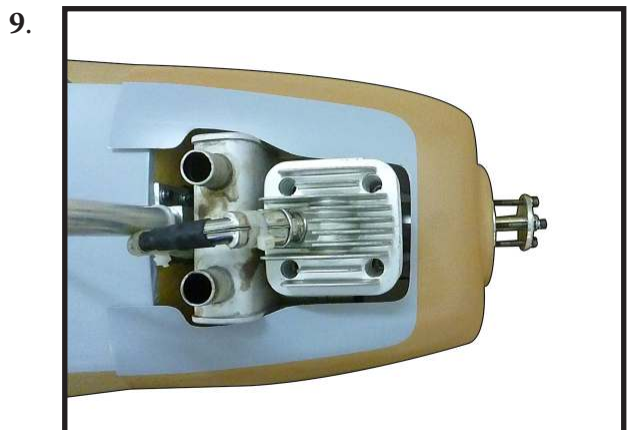

10.

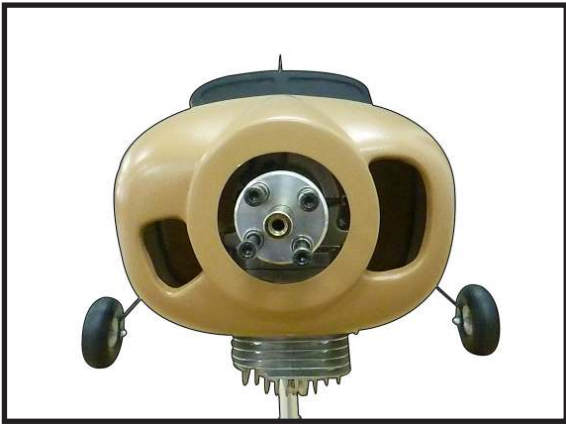

**ELECTRIC POWER CONVERSION**

Locate the items necessary to install the electric power conversion included with your model.

1.

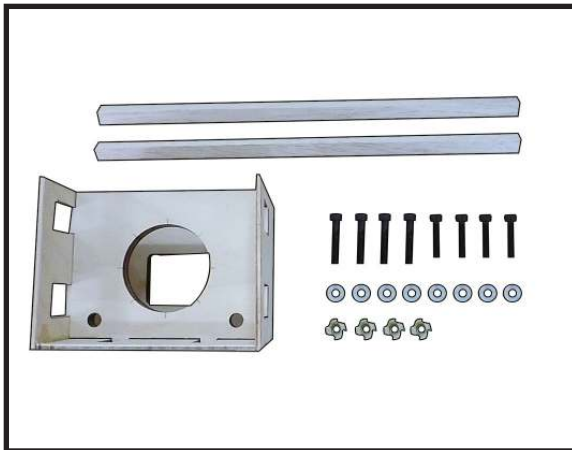

Recommended electric power system set-up for use with the included electric power conversion kit.

- **Motor: 160 - 2700 Watts**
- **Propeller: 18x8 ~ 20x10**
- **ESC: 70A - 100A**
- **9-10S Lipo**

Attach the electric motor box to the fire-wall centered with the cross lines drawn on the electric motor box and firewall. Using M5x25mm to secure the motor box to the firewall. Please see pictures below.

2.

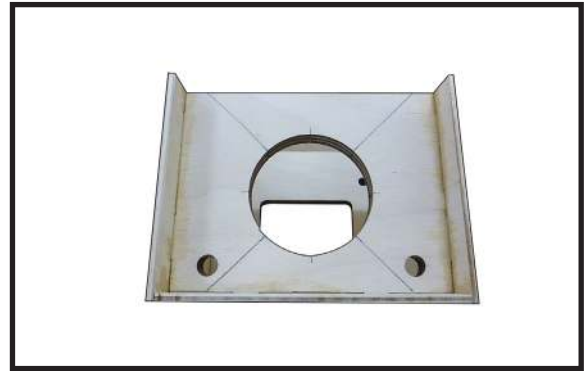

Attach the motor mount to the front of the electric motor box using four 5mm blind nut, four M5x25mm hex head bolts to secure the motor. Please refer to images below.

3.

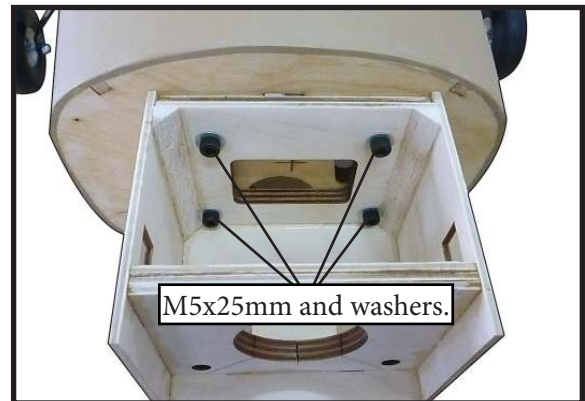

4.



5.

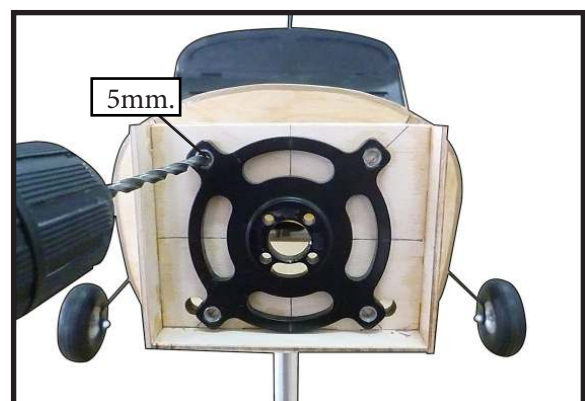



Then, use 7mm drill bit to enlarge the holes on the electric motor box.

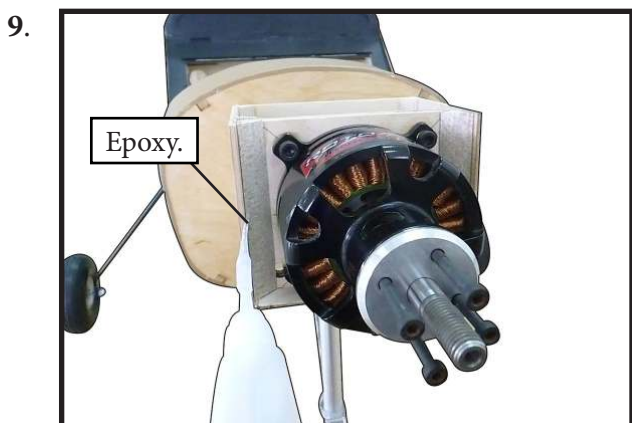
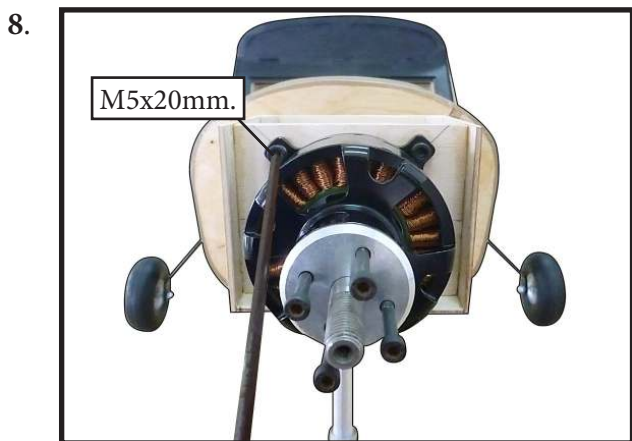
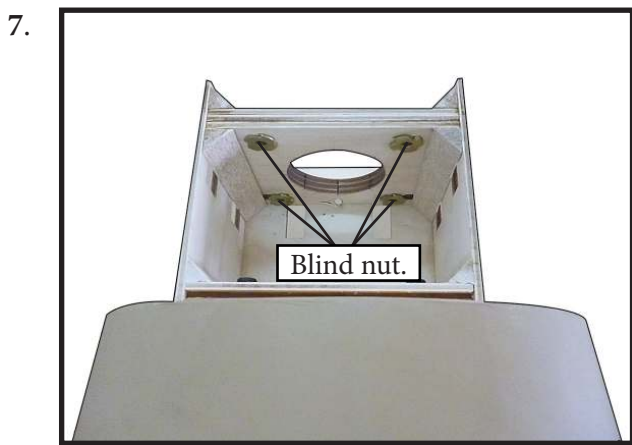
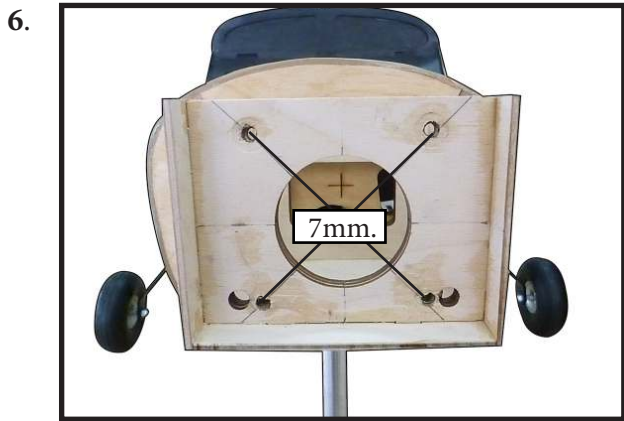

Attach the speed control to the side of the motor box using two-sided tape and tie wraps. Connect the appropriate leads from the speed control to the motor. Make sure the leads will not interfere with the operation of the motor.

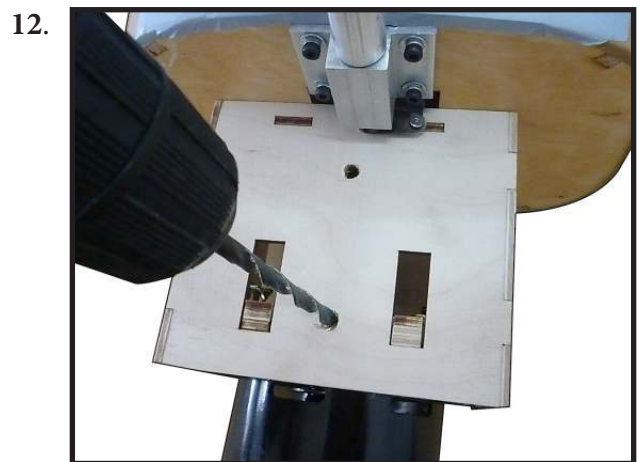
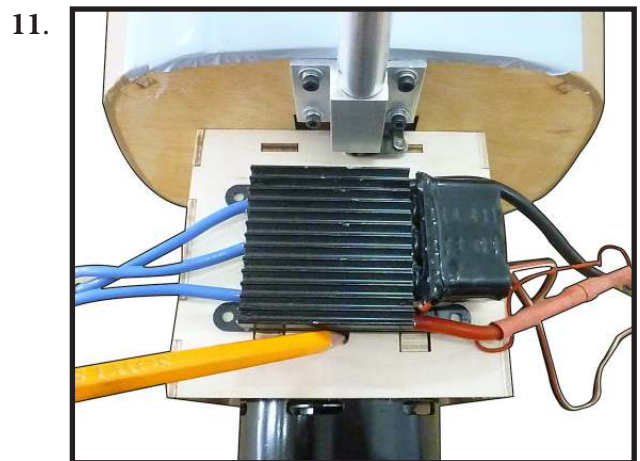
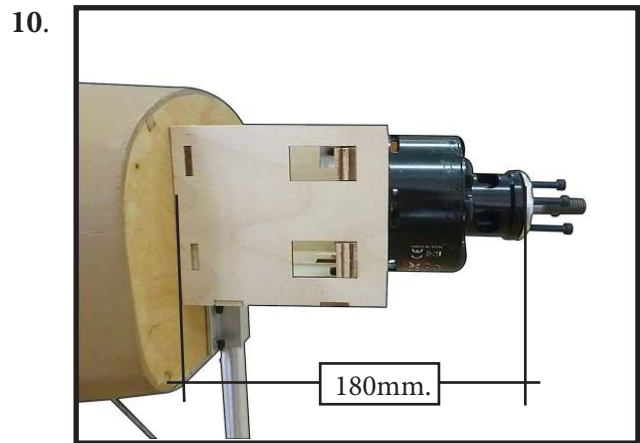

13.

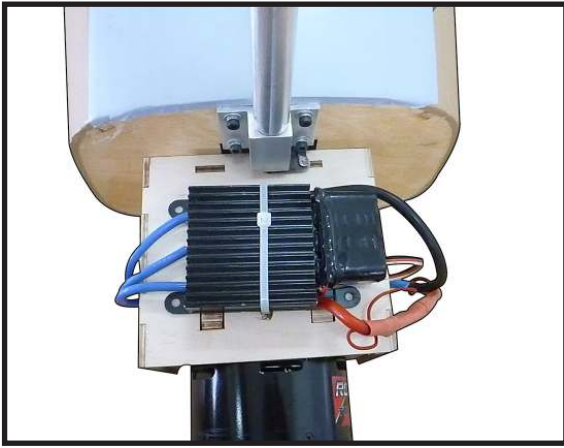

2.

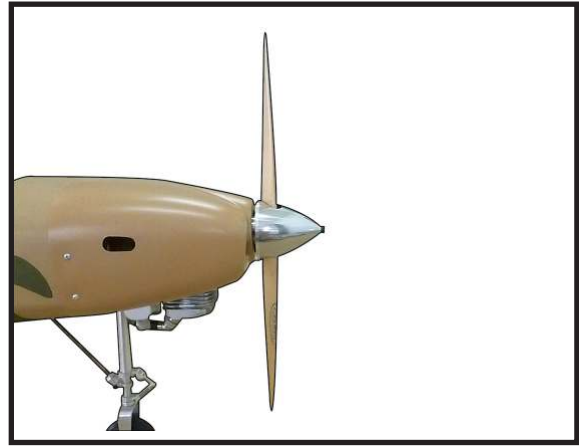

14.

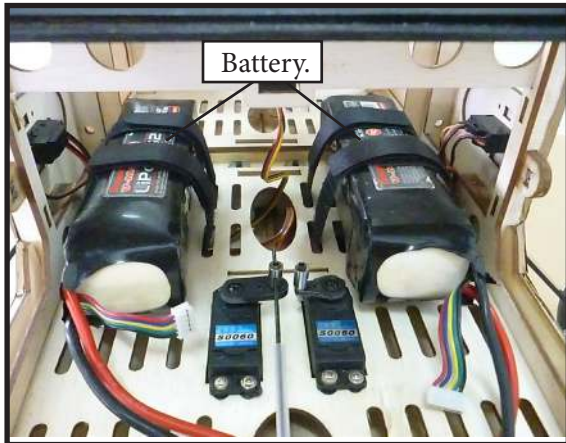

**HINGING THE ELEVATOR**

Glue the elevator hinges in place using the same techniques as shown in images below.

**INSTALLING THE SPINNER**

Install the spinner backplate, propeller and spinner cone.

1.



2.

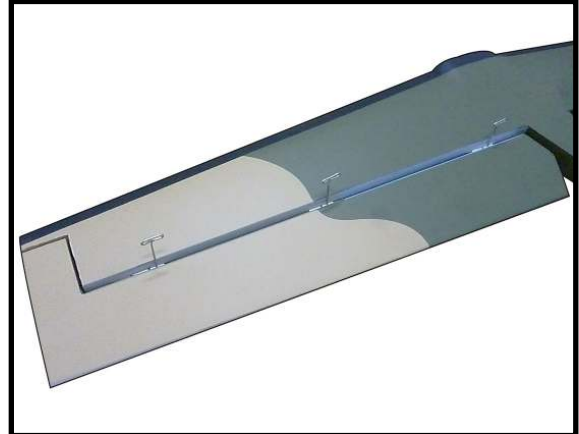

 The propeller should not touch any part of the spinner cone. If it does, carefully trim spinner cone opening until propeller no longer comes in contact with it.

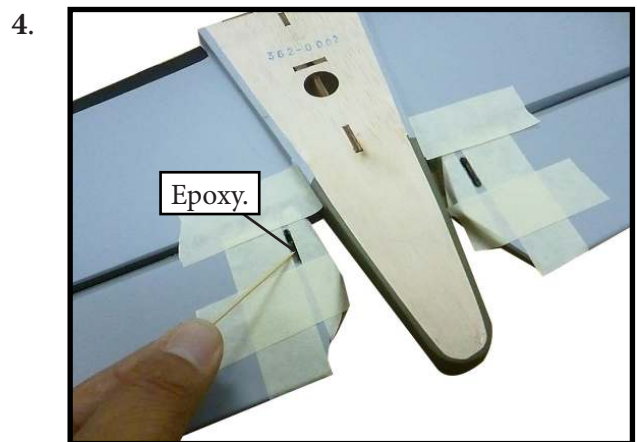
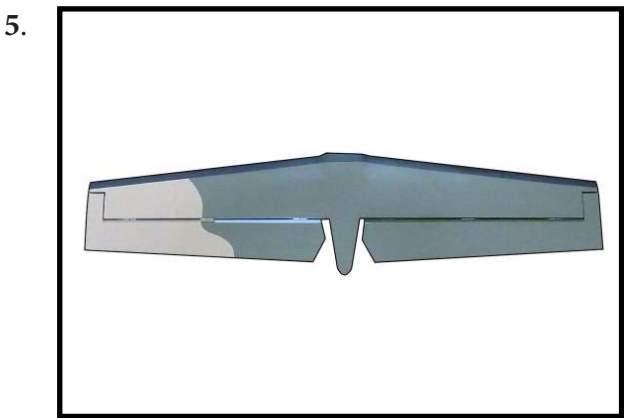
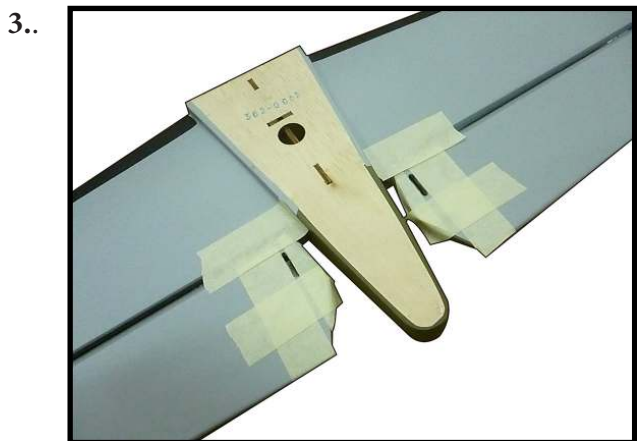
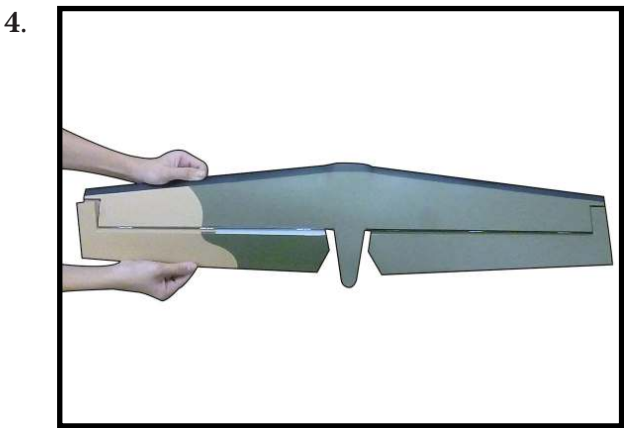
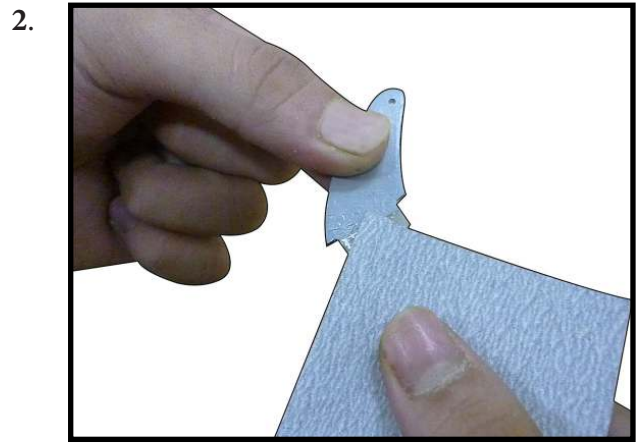
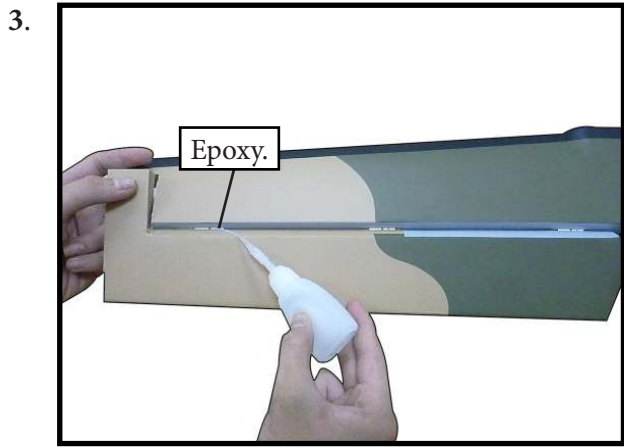

**INSTALL ELEVATOR CONTROL HORN**

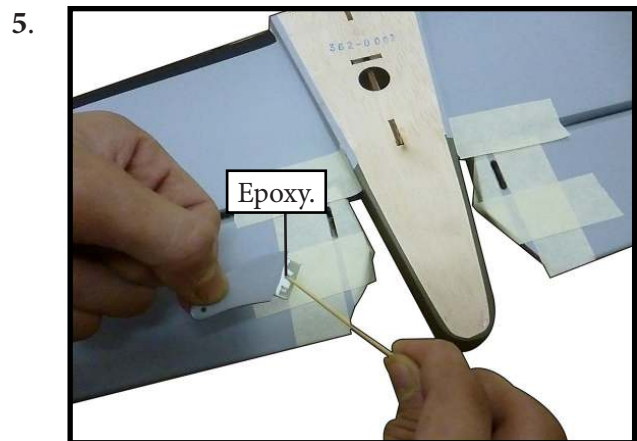
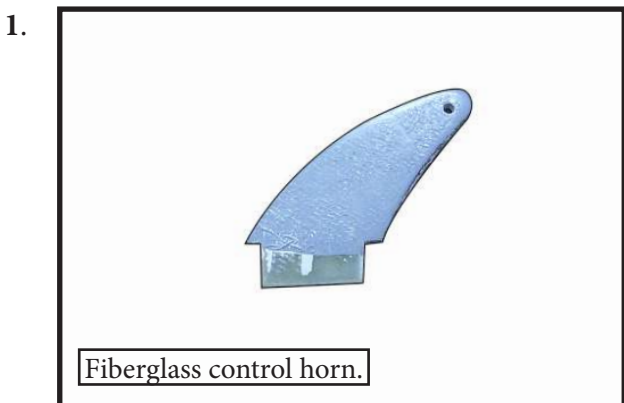



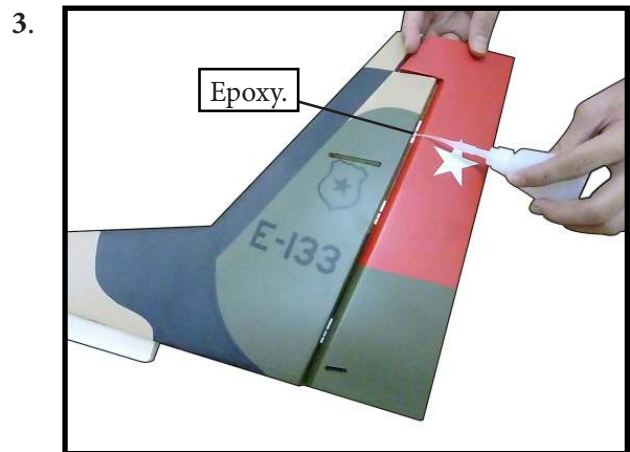
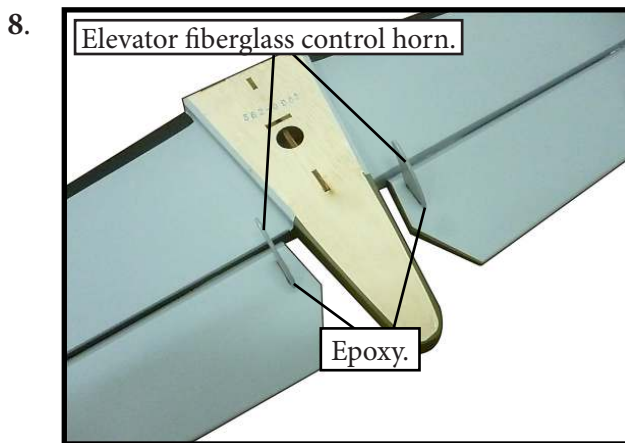
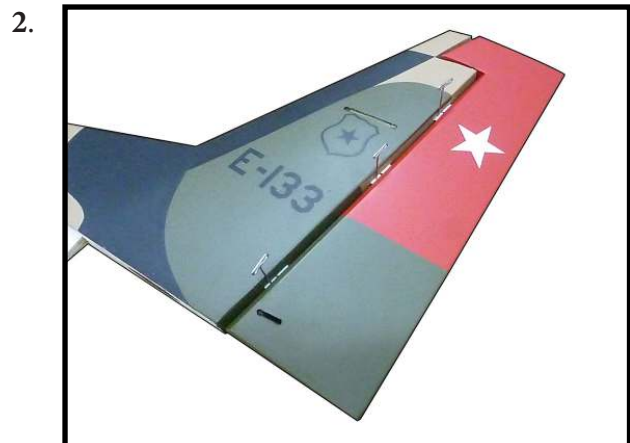
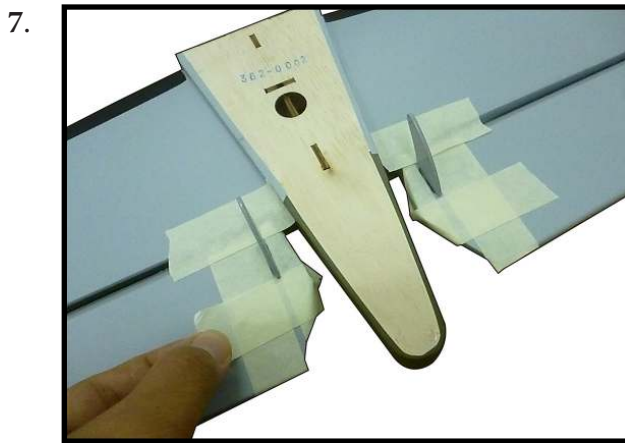
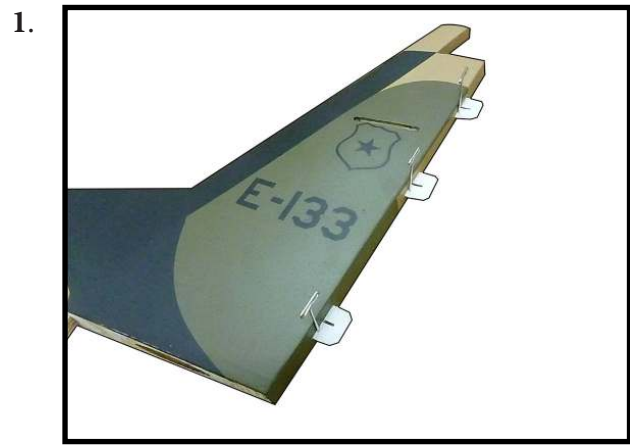
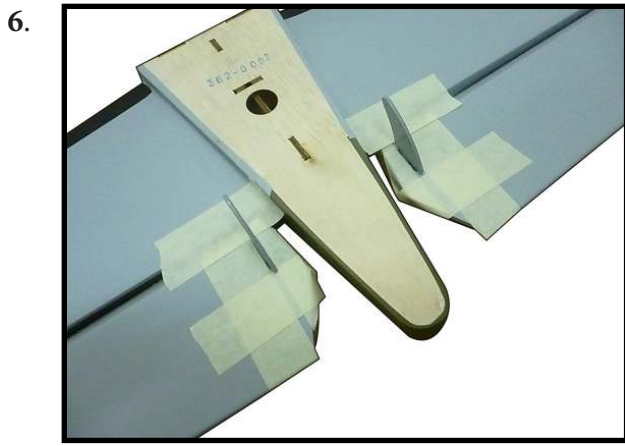

**HINGING THE RUDDER**

Glue the top three rudder hinges in place using the same techniques used to hinge the elevator.

The lower hinge will be glued when the fin/rudder assembly is attached to the fuselage.

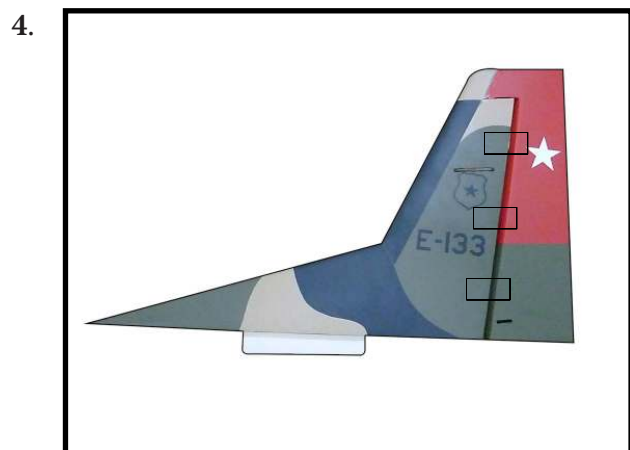



## INSTALL RUDDER CONTROL HORN

Repeat steps to install the rudder control horn as same as steps done for elevator.

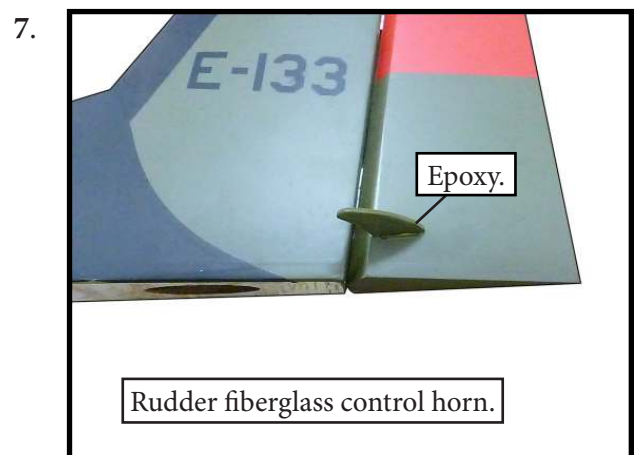
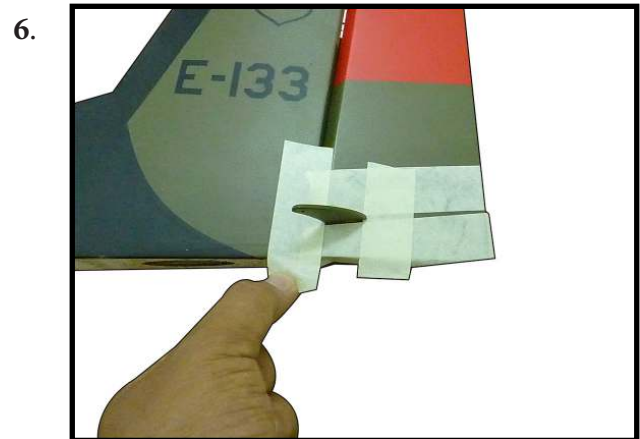
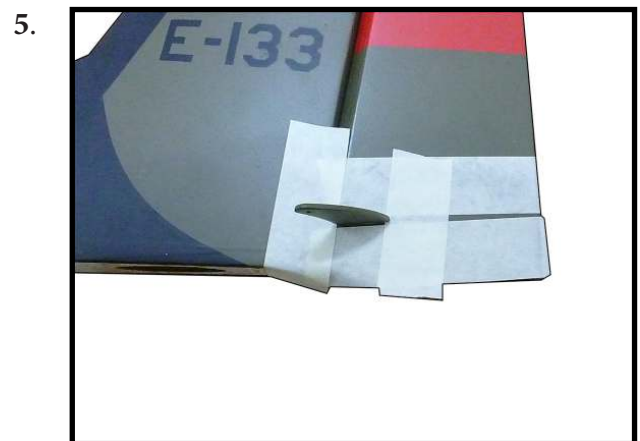
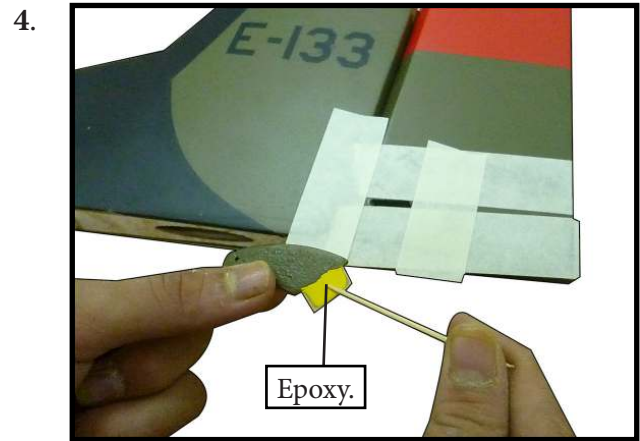
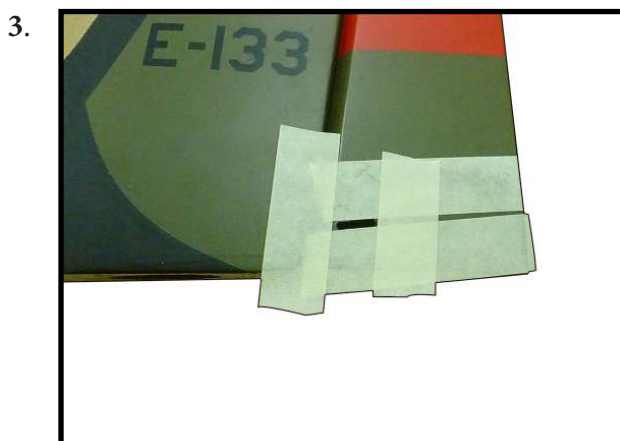
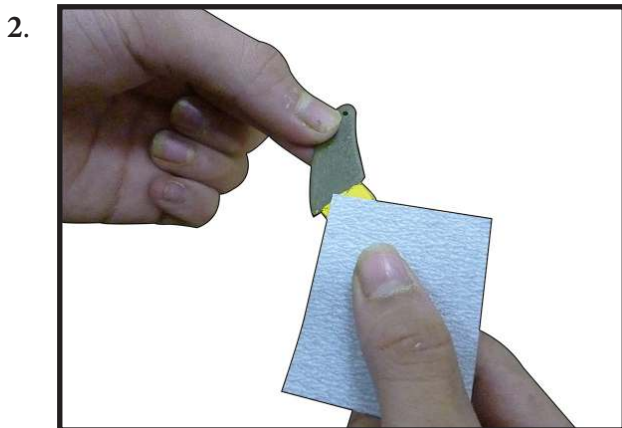

## INSTALLING THE HORIZONTAL STABILIZER

Using a ruler and a pen, locate the centerline of the horizontal stabilizer, at the trailing edge, and place a mark. Use a triangle and extend this mark, from back to front, across the top of the stabilizer. Also extend this mark down the back of the trailing edge of the stabilizer.

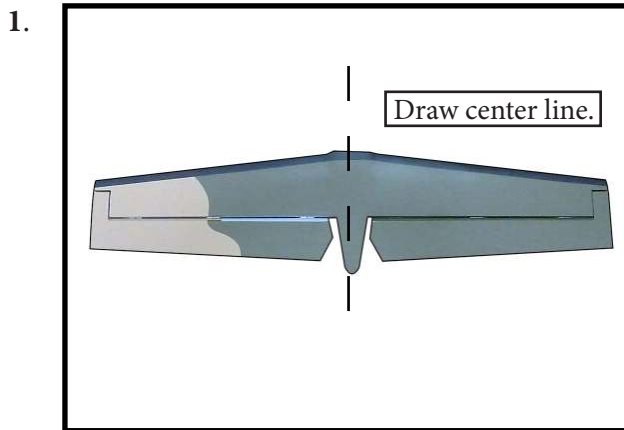

Using a modeling knife, carefully remove the covering at mounting slot of horizontal stabilizer (both side of fuselage).

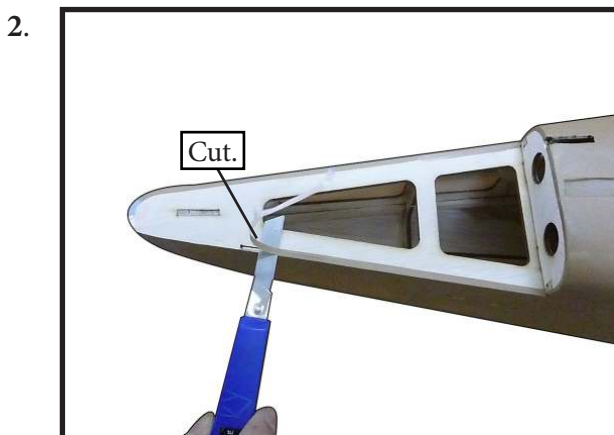

Slide the stabilizer into place in the pre-cut slot in the rear of the fuselage. The stabilizer should be pushed firmly against the front of the slot.

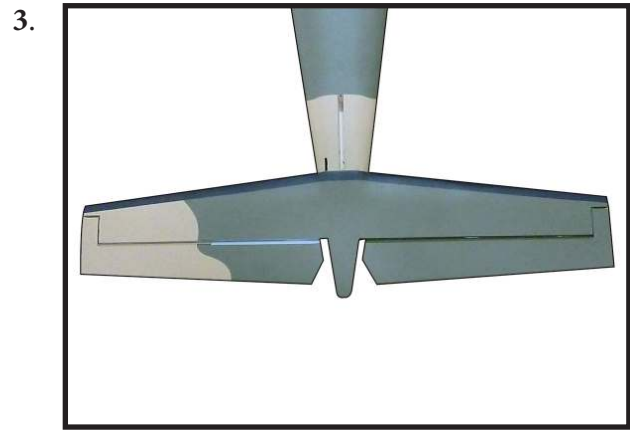

With the stabilizer held firmly in place, use a pen and draw lines onto the stabilizer where it and the fuselage sides meet. Do this on both the right and left sides and top and bottom of the stabilizer.

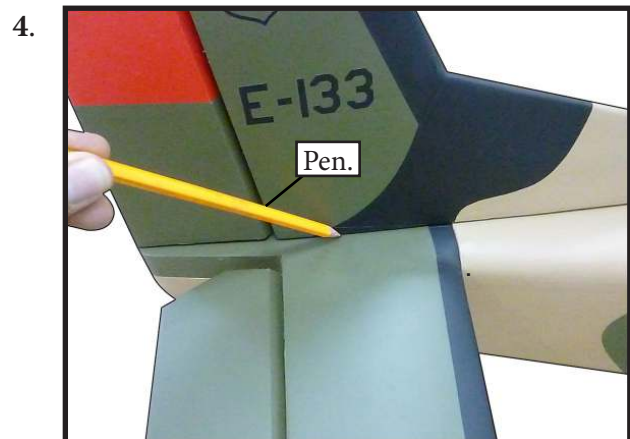

 *When cutting through the covering to remove it, cut with only enough pressure to only cut through the covering itself. Cutting into the balsa structure may weaken it.*

Using a modeling knife, carefully remove the covering that overlaps the stabilizer mounting platform sides in the fuselage. Remove the covering from both the top and the bottom of the platform sides.

5.

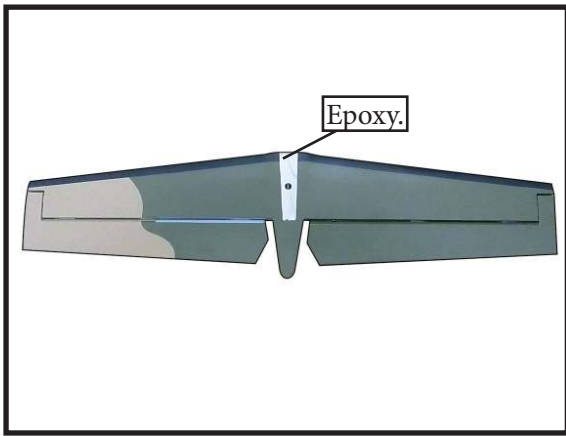

When you are sure that everything is aligned correctly, mix up a generous amount of 30 Minute Epoxy. Apply a thin layer to the top and bottom of the stabilizer mounting area and to the stabilizer mounting platform sides in the fuselage. Slide the stabilizer in place and realign. Double check all of your measurements once more before the epoxy cures. Hold the stabilizer in place with T-pins or masking tape and remove any excess epoxy using a paper towel and rubbing alcohol.

6.

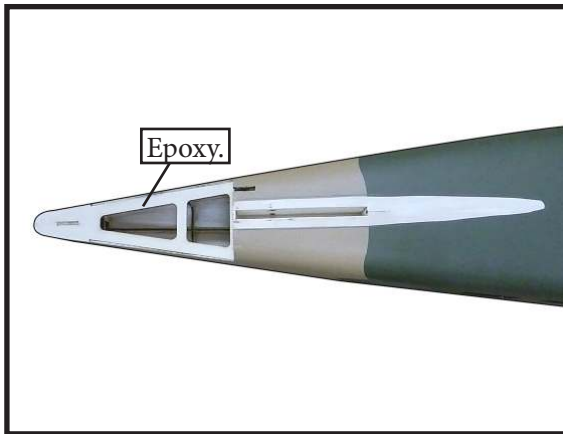

7.

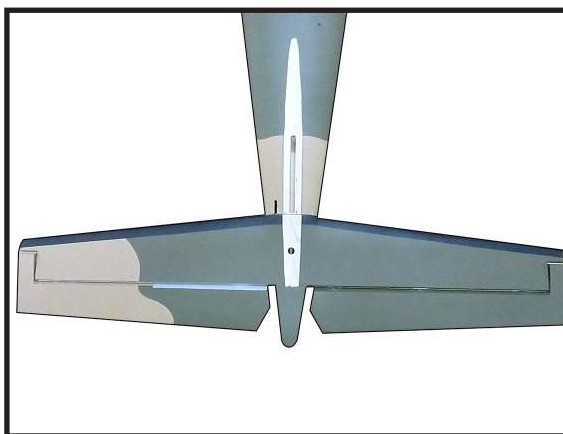

## INSTALLING VERTICAL STABILIZER

1.

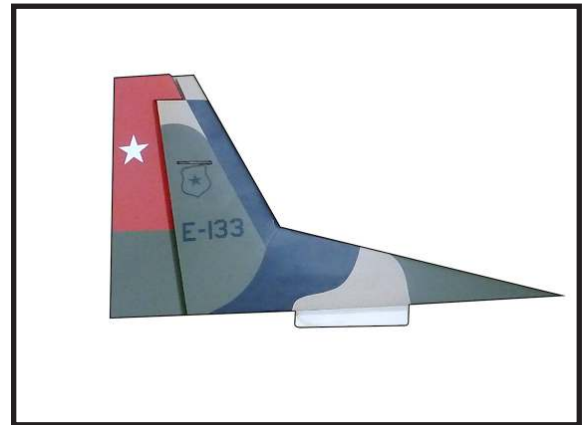

Using a modeling knife, remove the covering from over the precut hinge slot cut into the lower rear portion of the fuselage. This slot accepts the lower rudder hinge.

2.

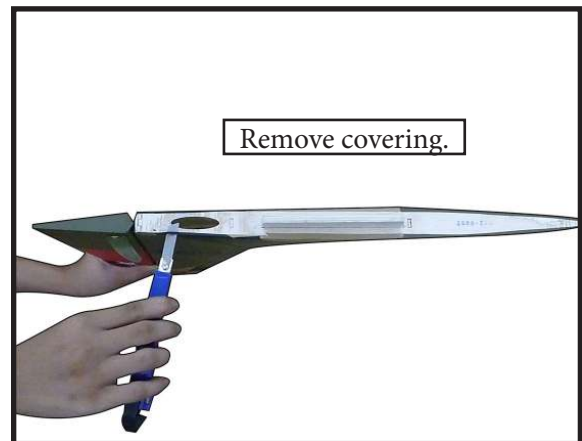

3.

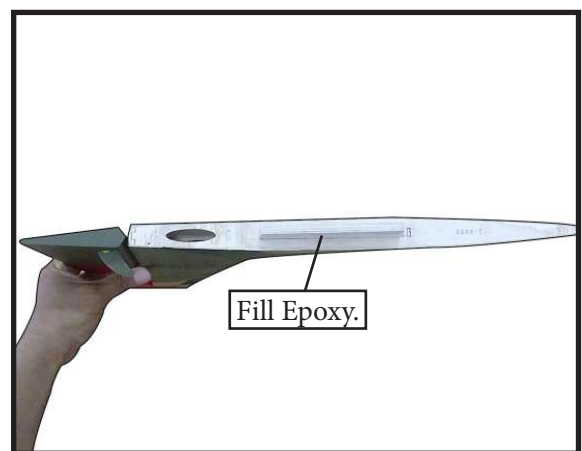

Slide the vertical stabilizer into the slot in the top of the fuselage. The rear edge of the stabilizer should be flush with the rear edge of the fuselage and the lower rudder hinge should engage the precut hinge slot in the lower fuselage. The bottom edge of the stabilizer should also be firmly pushed against the top of the horizontal stabilizer.

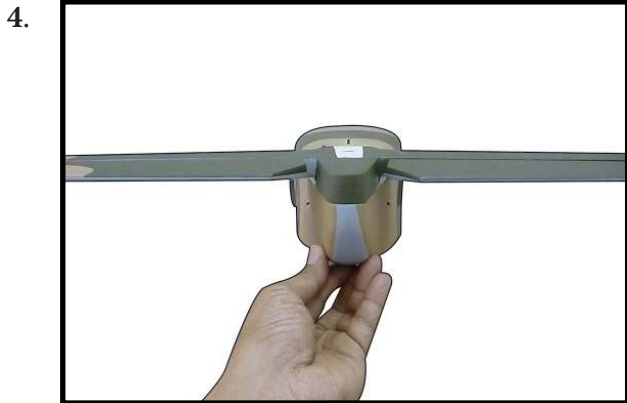

While holding the vertical stabilizer firmly in place, use a pen and draw a line on each side of the vertical stabilizer where it meets the top of the fuselage.

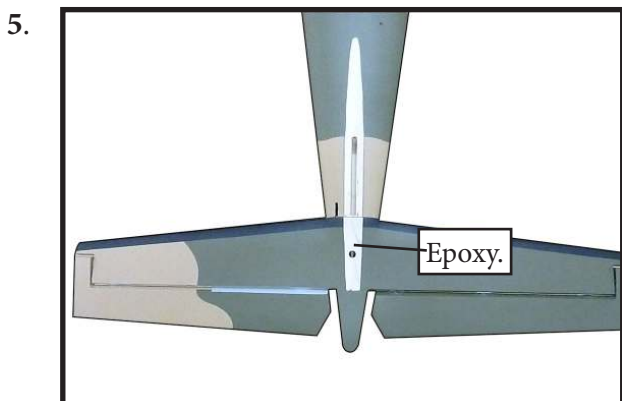

Slide the vertical stabilizer back in place. Using a triangle, check to ensure that the vertical stabilizer is aligned 90° to the horizontal stabilizer.

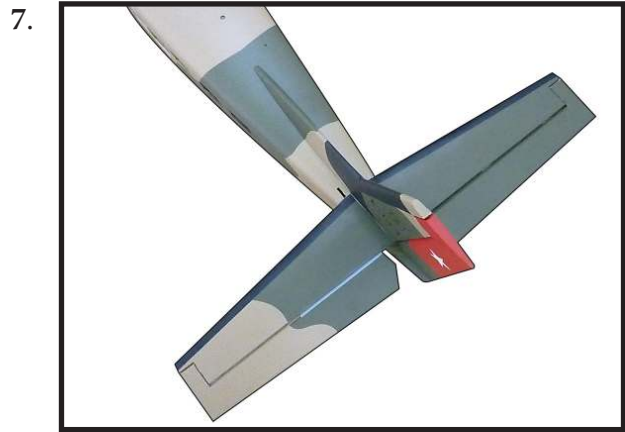
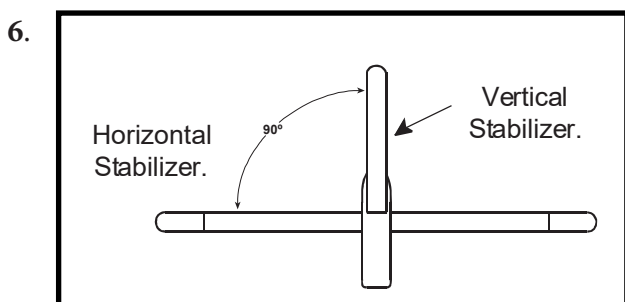

When you are sure that everything is aligned correctly, mix up a generous amount of Flash 30 Minute Epoxy. Apply a thin layer to the mounting slot and to bottom of the vertical stabilizer mounting area. Apply epoxy to the bottom and top edges of the filler block and to the lower hinge also. Set the stabilizer in place and realign. Double check all of your measurements once more before the epoxy cures. Hold the stabilizer in place with T-pins or masking tape and remove any excess epoxy using a paper towel and rubbing alcohol. Allow the epoxy to fully cure before proceeding.

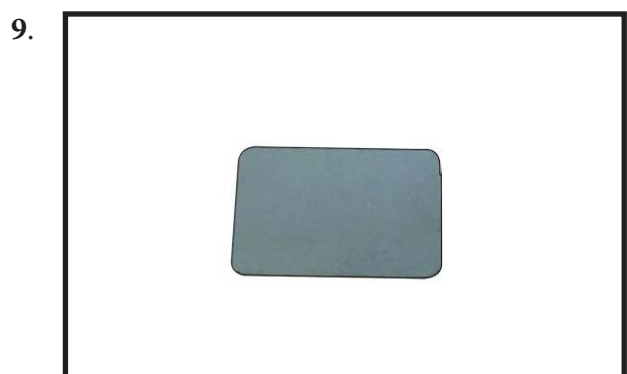





**ELEVATOR PUSHROD  
INSTALLATION**

Install the elevator control horn using the same method as with the aileron control horns.

Position the elevator control horn on the both side of elevator.

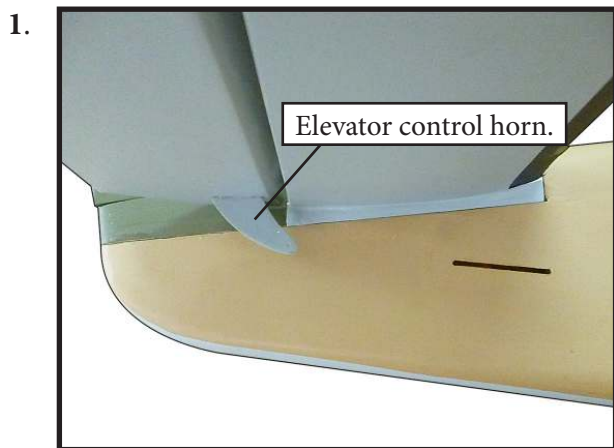

Thread one clevis and M2 lock nut on to each elevator control rod. Thread the horns on until they are flush with the ends of the control rods.

Elevator and rudder pushrod assembly shown in photos below.

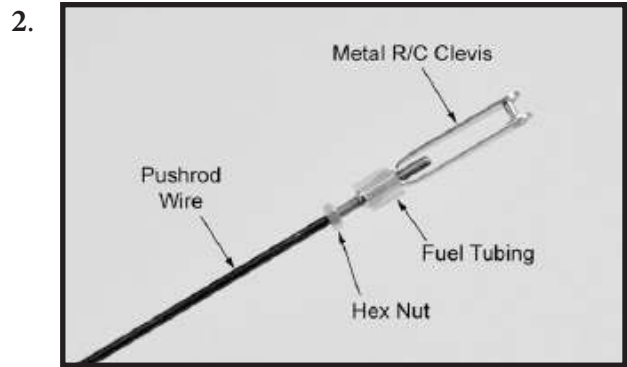

Locate items necessary to install rudder pushrod.

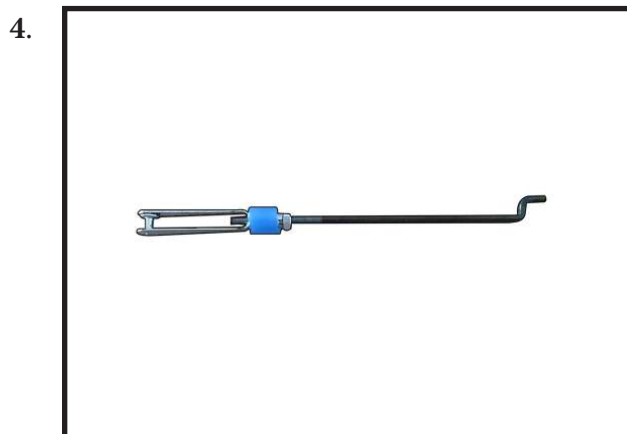
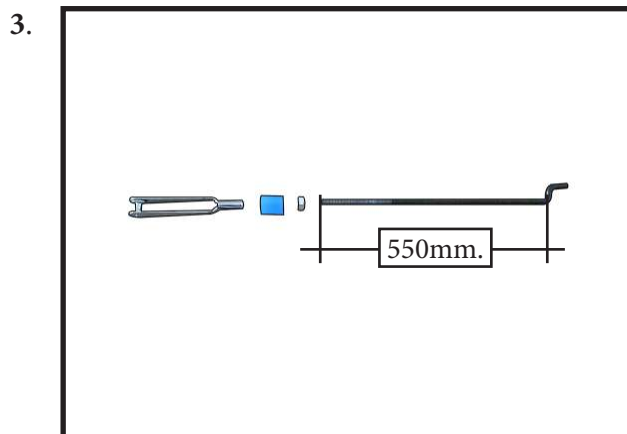

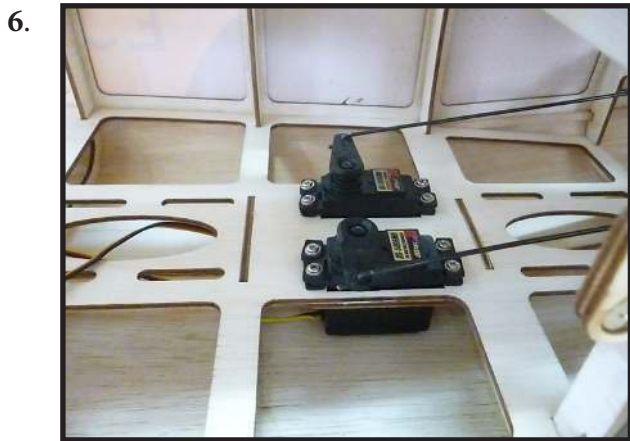

**RUDDER PUSHROD  
INSTALLATION**

Repeat steps as same as steps done for elevator.

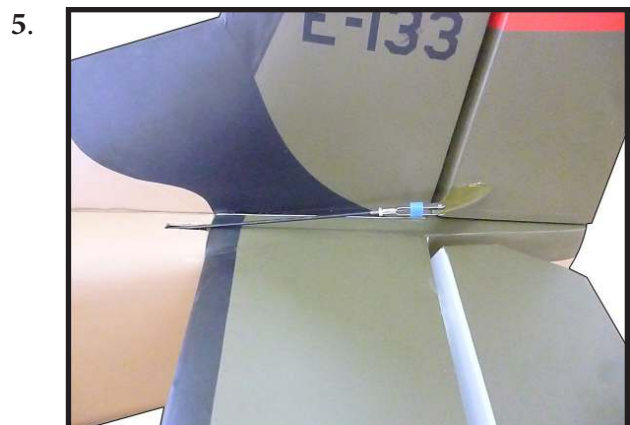
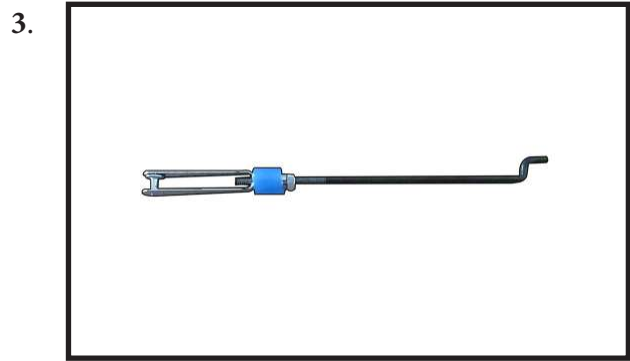
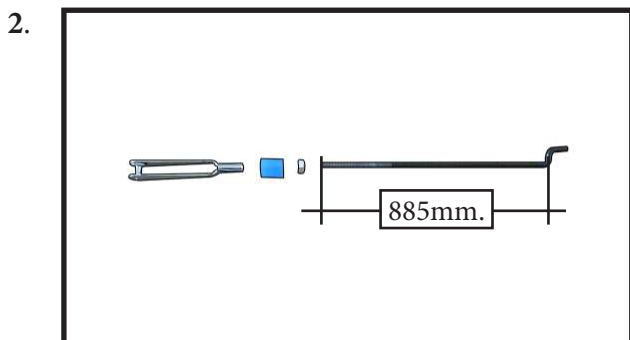

**INSTALL THE WINDOW**

Parts requirement. See pictures below.



2.



6.

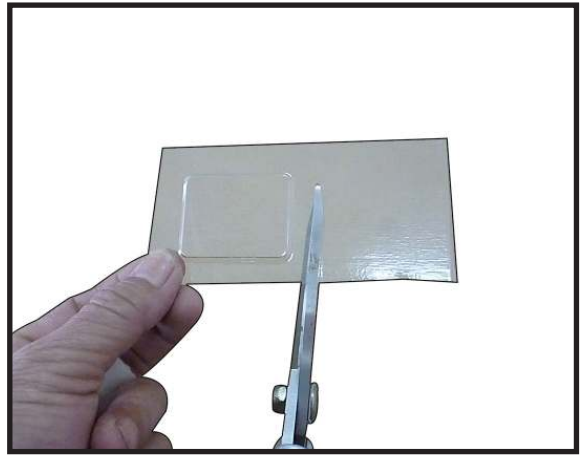

3.

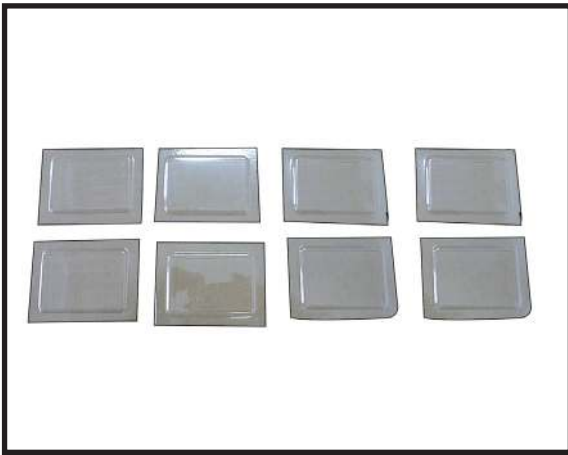

7.



4.

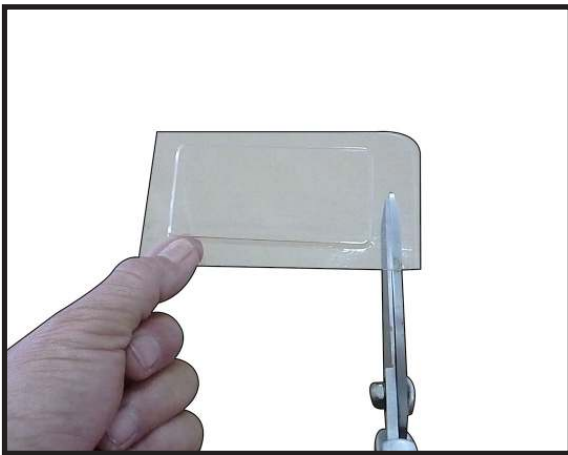

8.



5.

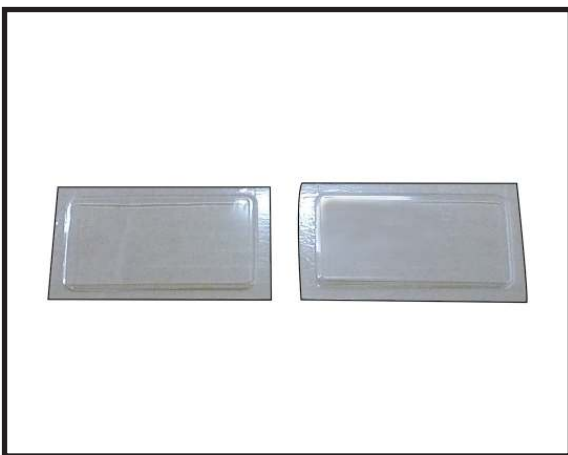

9.





10.

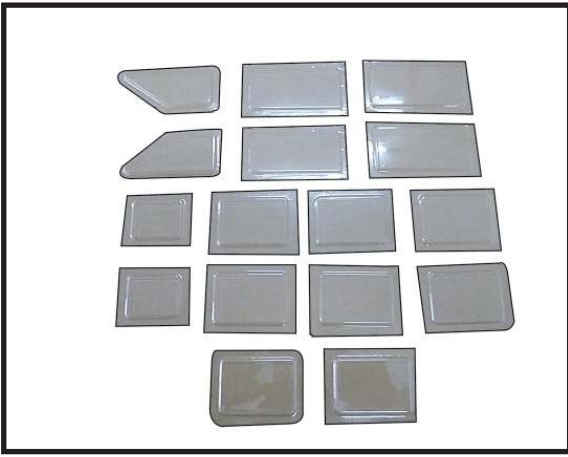

14.

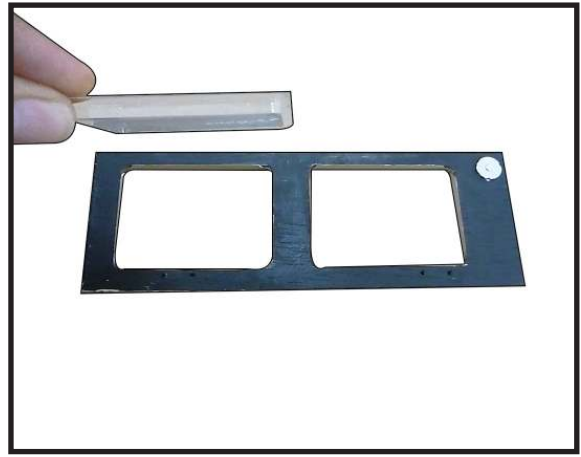

11.



15.



12.



16.



13.



17.



18.

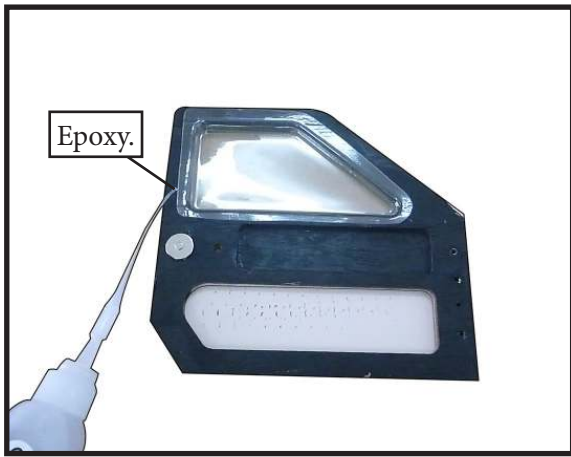

22.



19.



23.

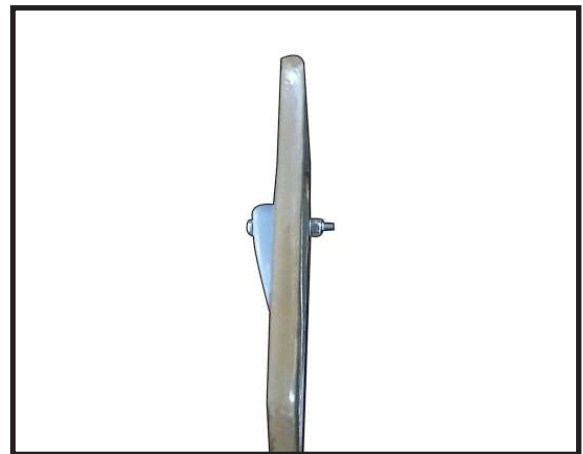

20.

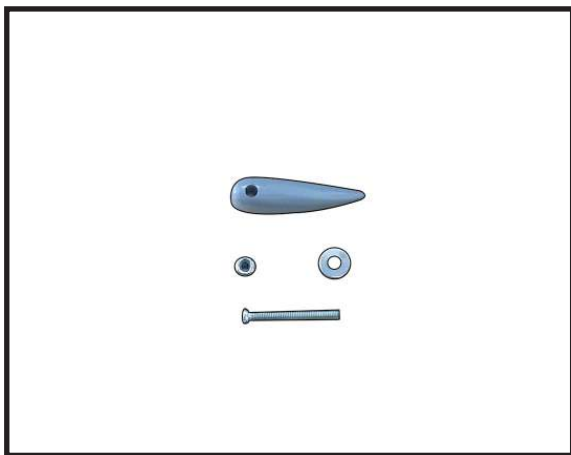

24.



21.

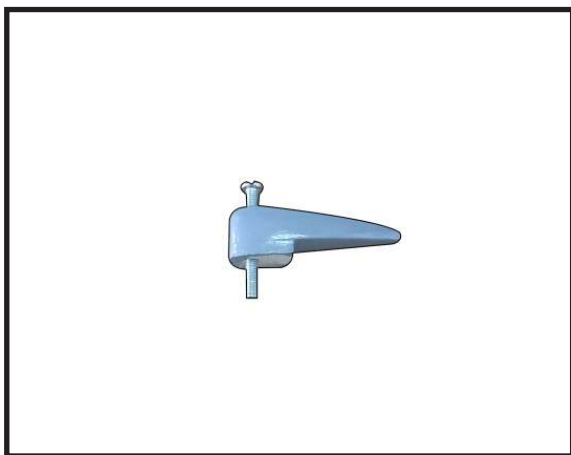

25.

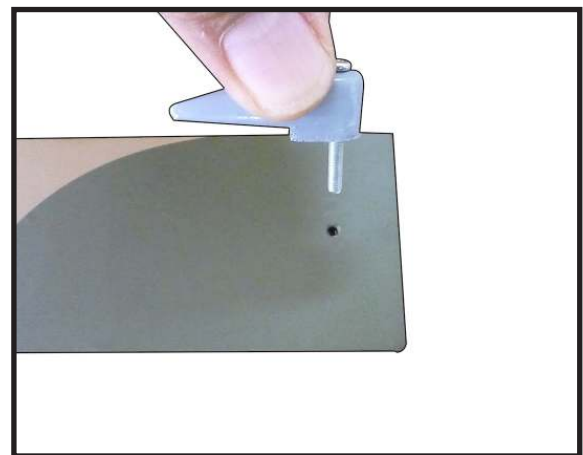

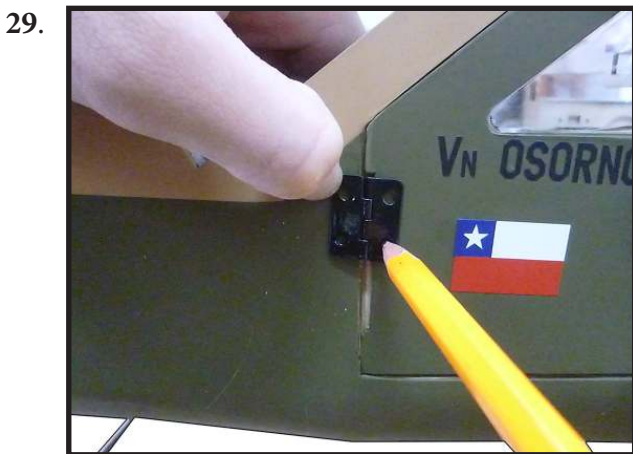
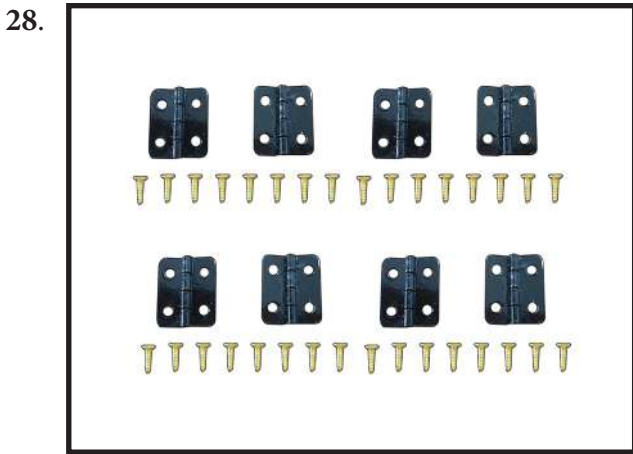
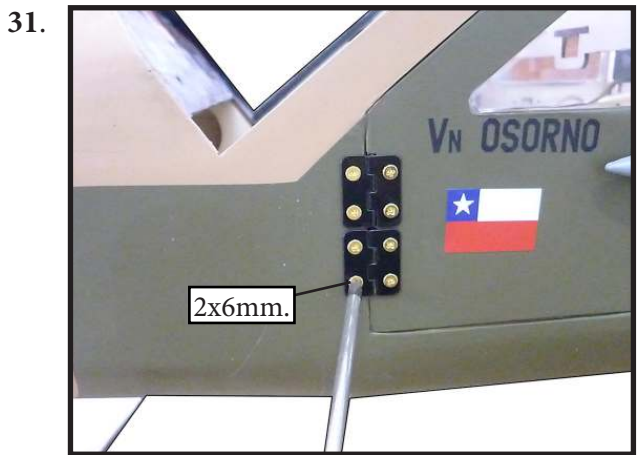
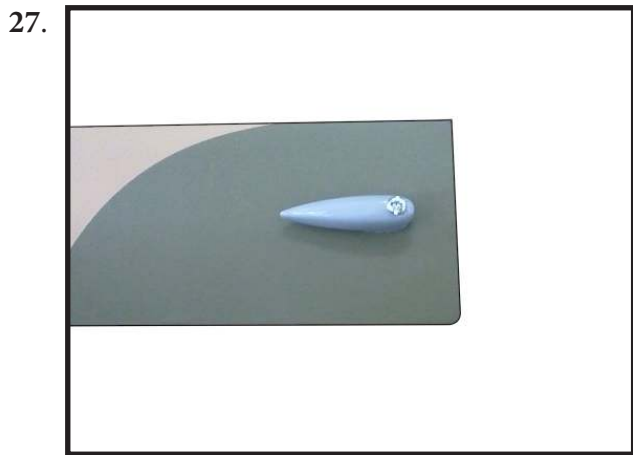
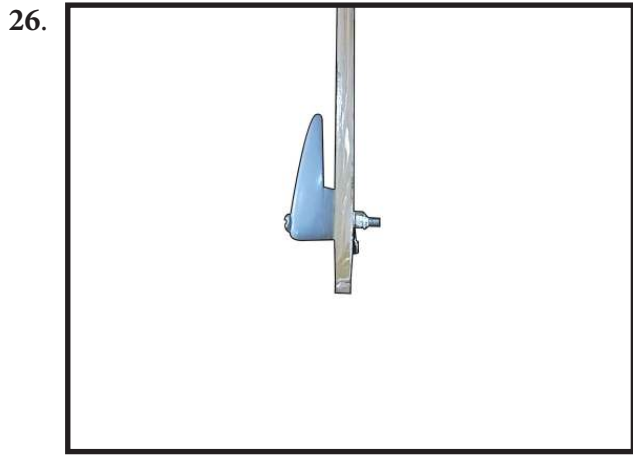



34.



38.



35.

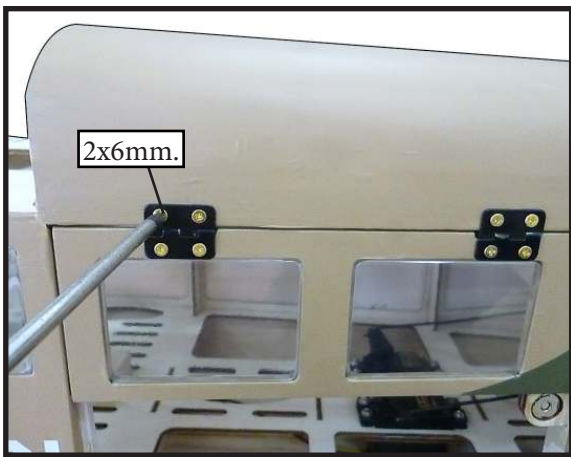

39.

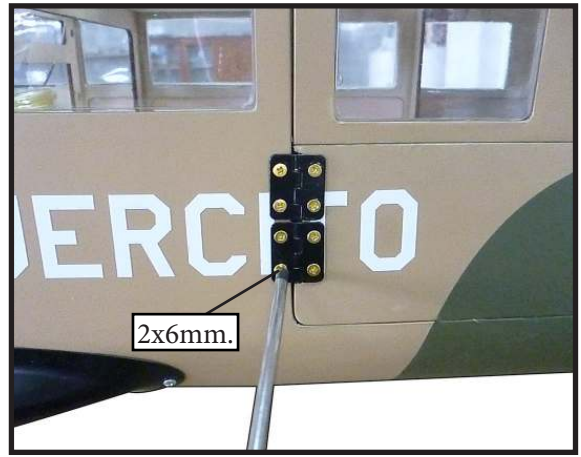

36.



40.



37.



41.



### INSTALLATION COCKPIT, PILOT AND CANOPY

Locate items necessary to install.

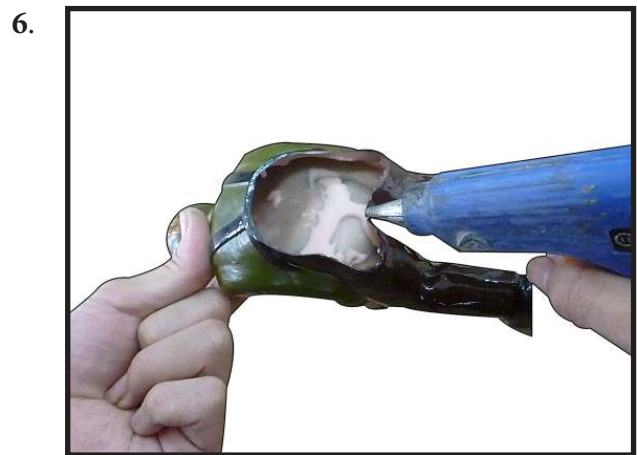
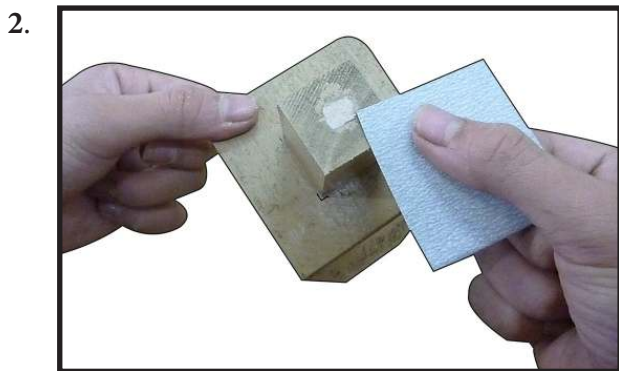



9.

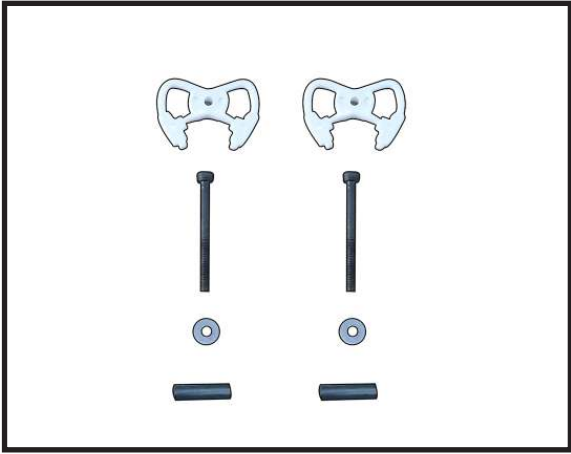

13.



10.

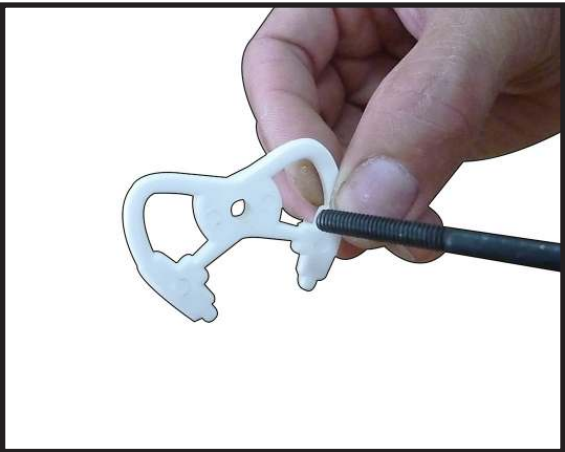

14.



11.

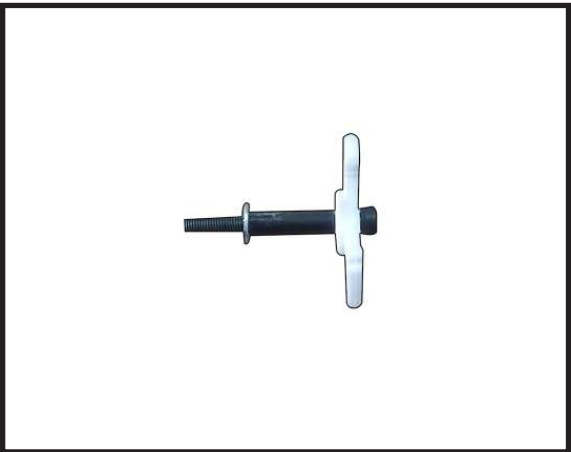

15.



12.



16.





**CARGO POD INSTALLATION**

Locate items necessary to install.

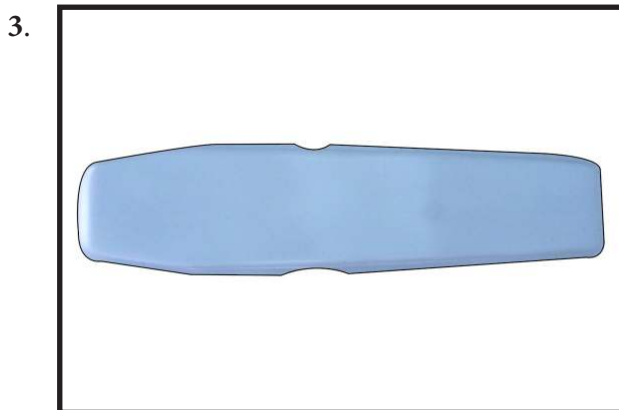
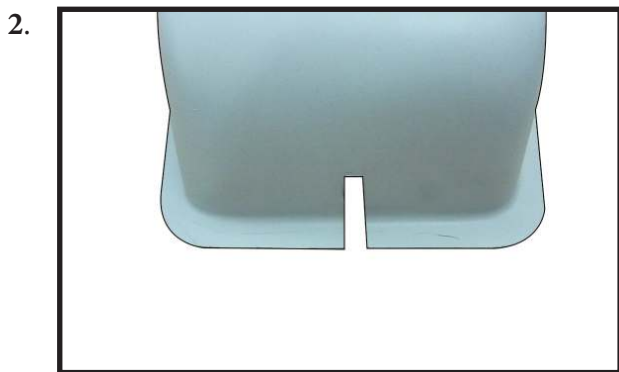

**INSTALLING TOW RELEASE FOR SAIL PLANE**

Screw the aero-tow mechanism into the hole just behind the canopy, and apply thread-lock fluid to prevent the coupling and nut from working loose.

The aluminium part must be shortened enough so that the clevis can move freely, adjust the rods accordingly.



2.



3.



4.



It is best to operate the aero-tow release mechanism using a momentary switch mounted on the transmitter. The servo travel must be set accordingly.

## INSTALLING BATTERY - RECEIVER

Plug the servos leads and the switch lead into the receiver. Plug the battery pack lead into the switch also.

Wrap the receiver and battery pack in the protective foam rubber to protect them from vibration.

1.

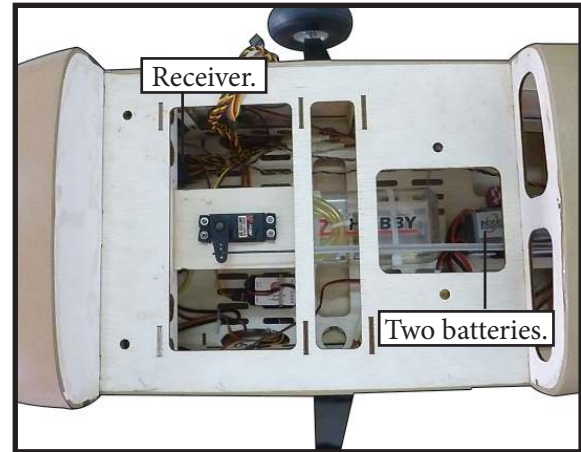

## ATTACHMENT WING- FUSELAGE

Parts requirement. See pictures below.

1.

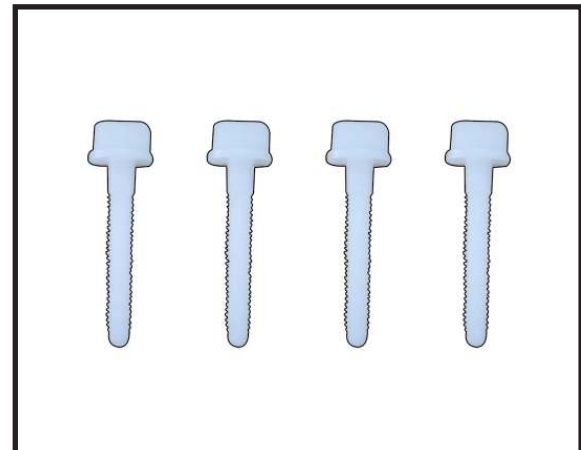

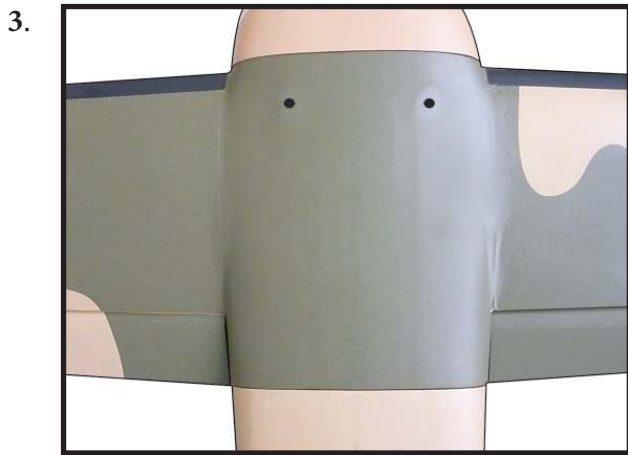

Then, install struts on the wings and fuselage.

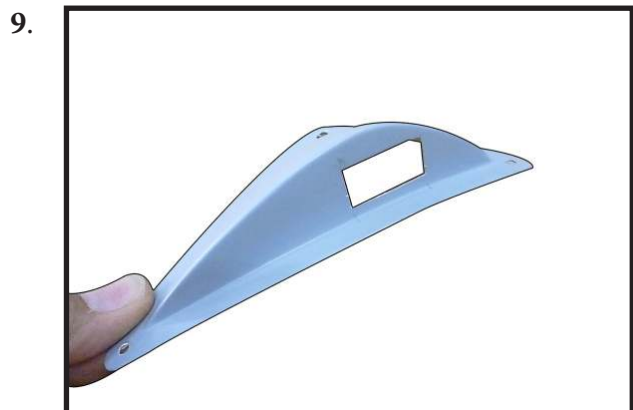
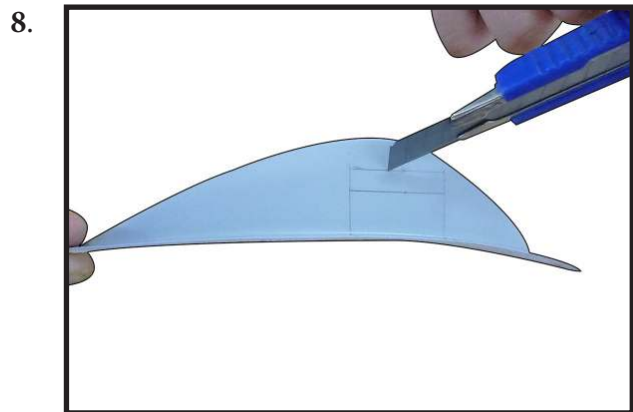
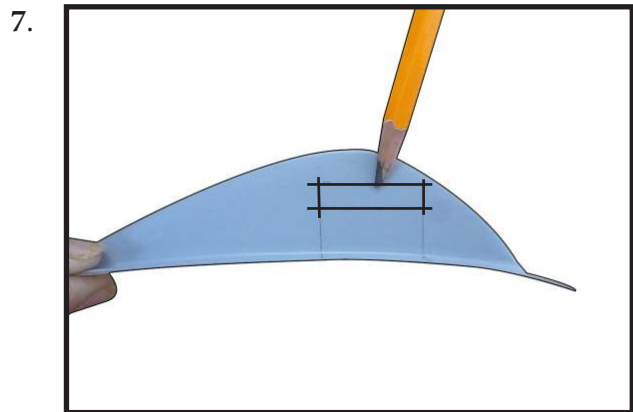



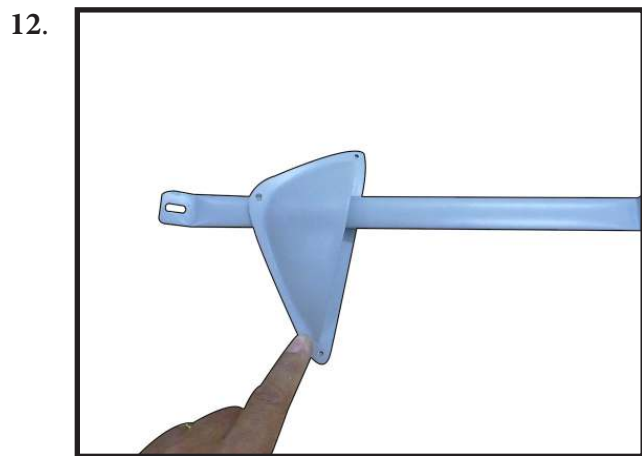
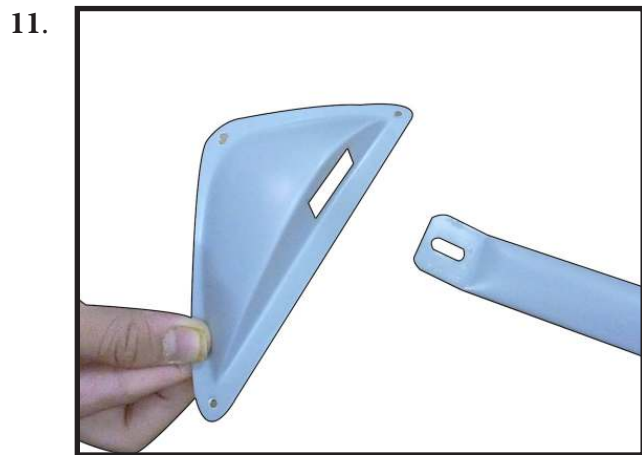
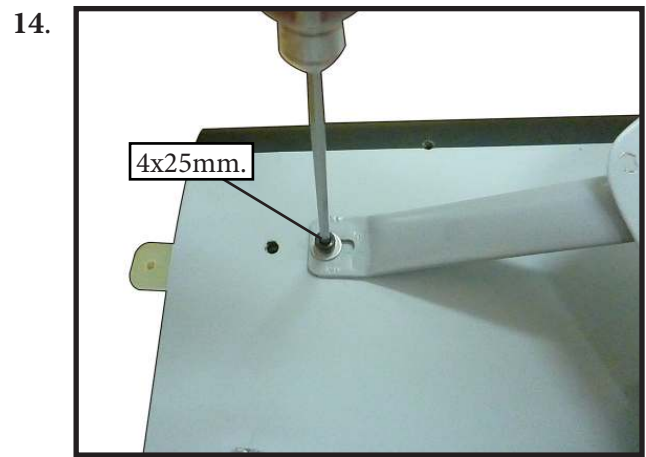
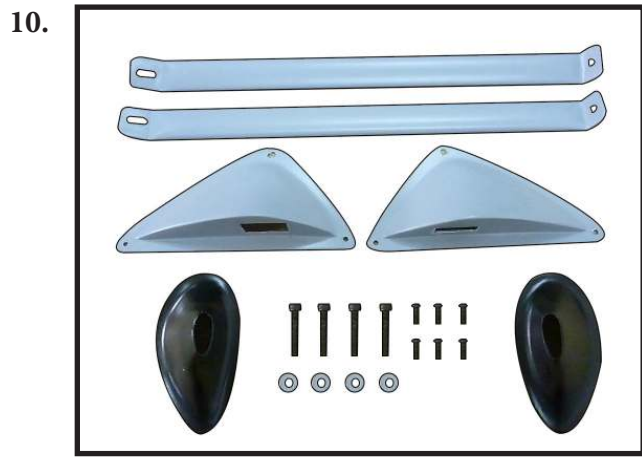

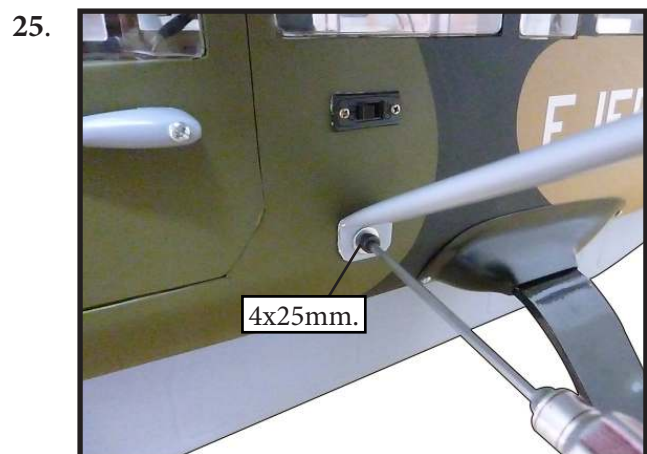
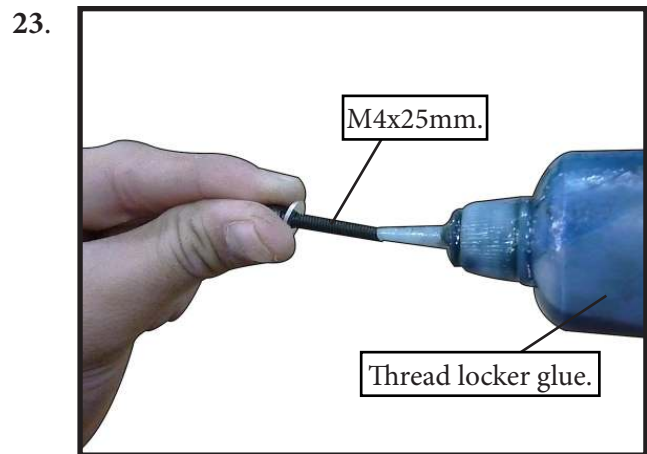
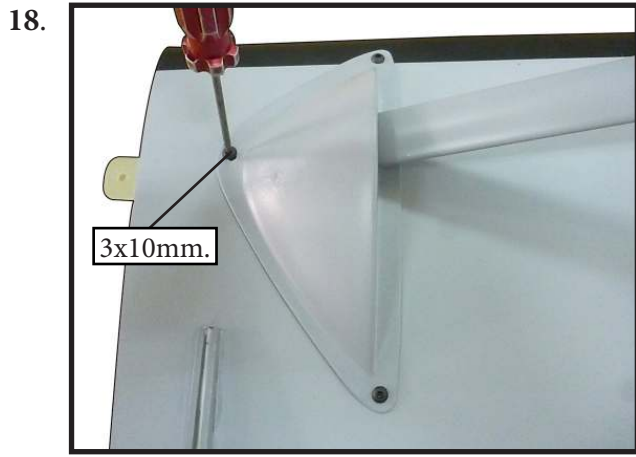



**ANTENNA INSTALLATION**

- Parts requirement. See pictures below.

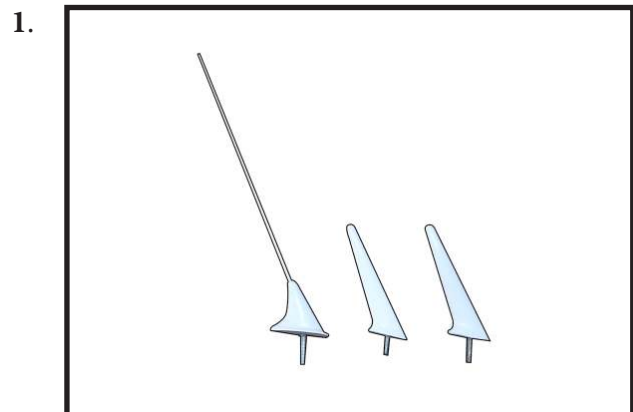



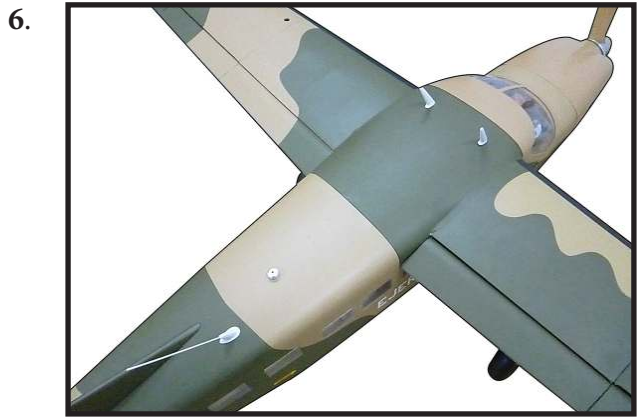
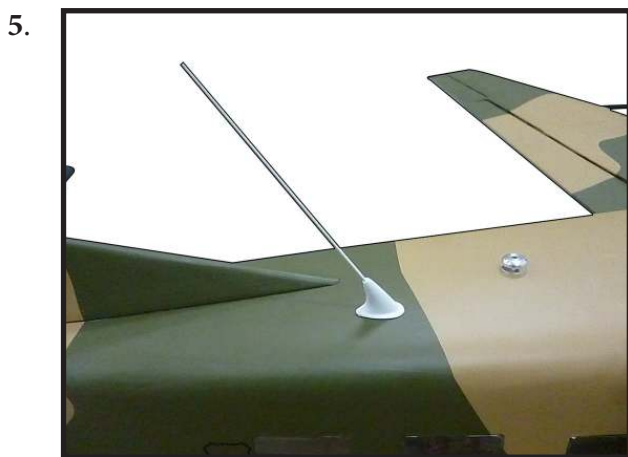
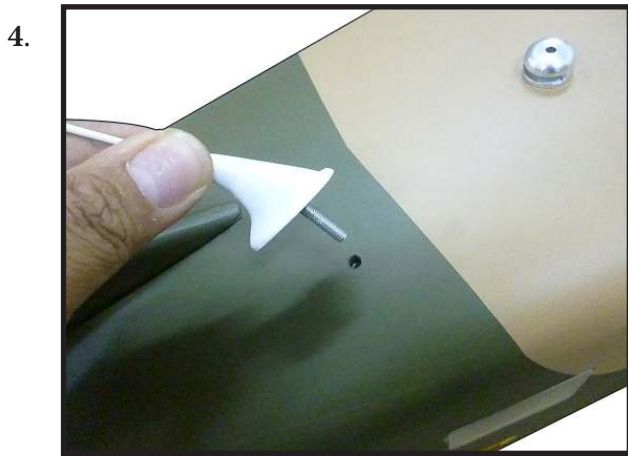
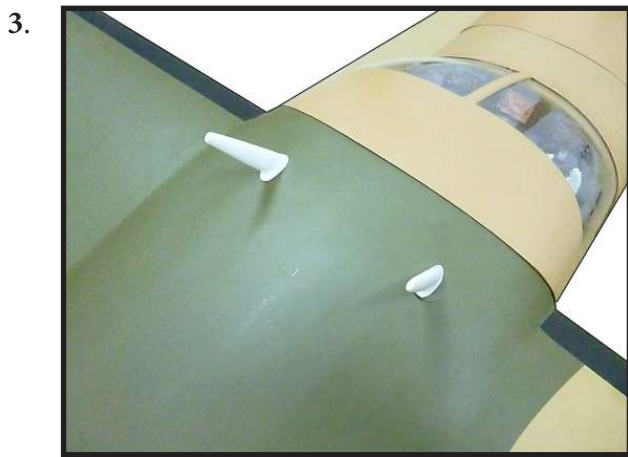
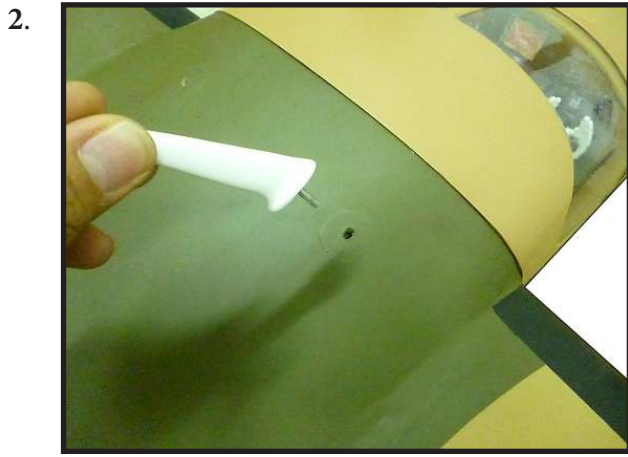

**INSTALLING THE PITOT TUBES & POD**

Parts needed are shown in images below:



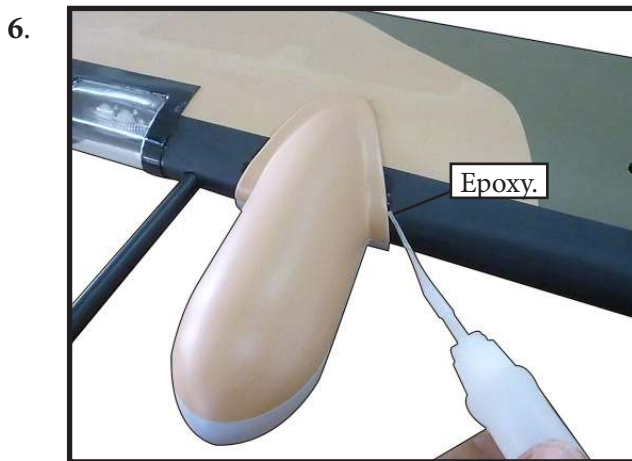
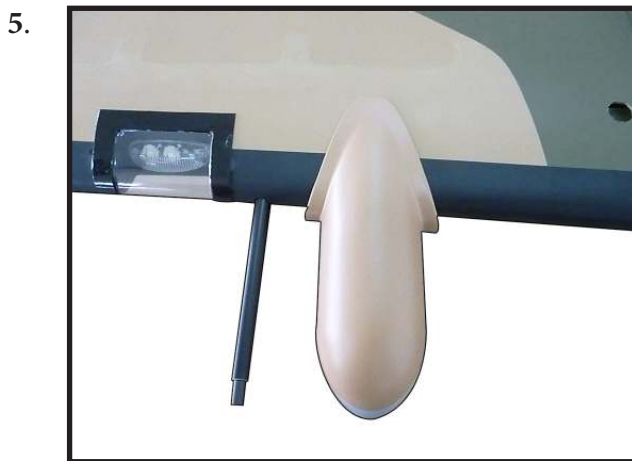
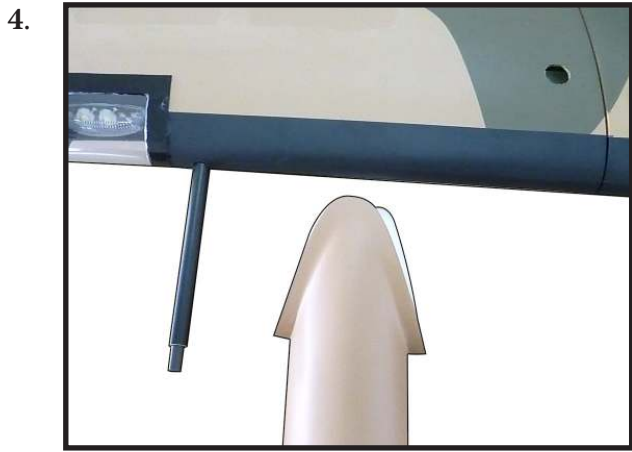

## ATTACHMENT WING- FUSELAGE

Attach the aluminium tube into fuselage.

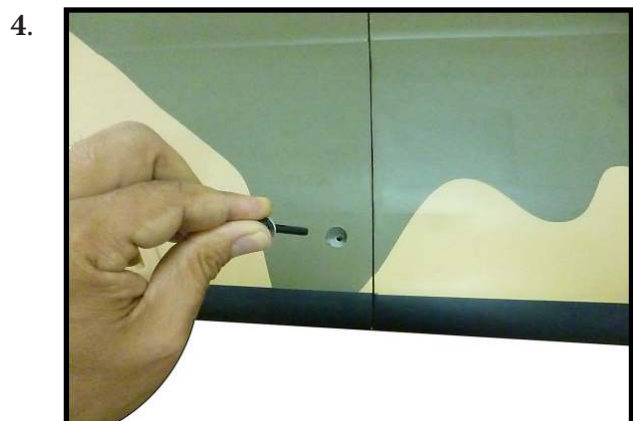
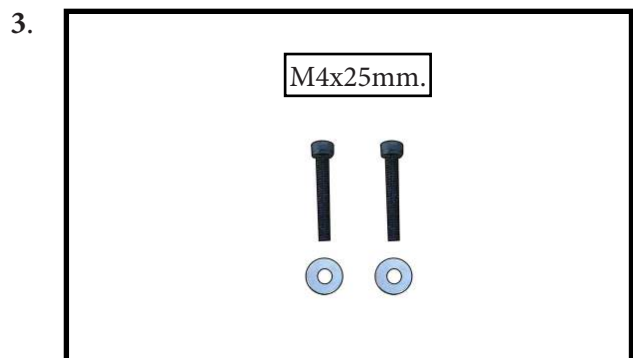
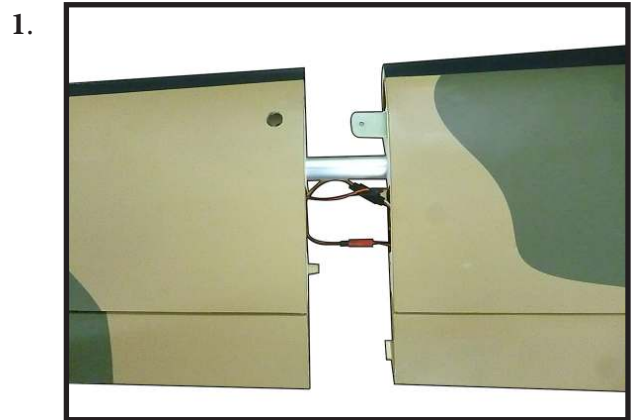

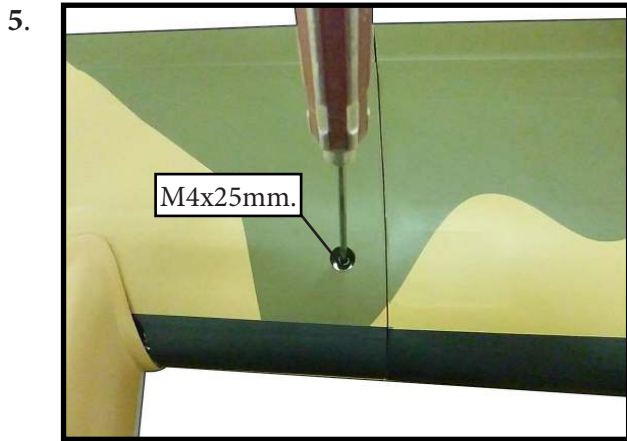

### APPLY THE DECALS

If all the decals are pre-cut and ready to stick. Please be certain the model is clean and free from oily fingerprints and dust. Position decal on the model where desired, using the photos on the box and aid in their location.

If all the decals are not pre-cut, please use scissors or a sharp hobby knife to cut the decals from the sheet. Please be certain the model is clean and free from oily fingerprints and dust. Position decal on the model where desired, using the photos on the box and aid in their location.

### BALANCING

An important part of preparing the aircraft for flight is properly balancing the model.

1) Attach the wing panels to the fuselage. Make sure to connect the leads from the aileron to the appropriate leads from the receiver. Make sure the leads are not exposed outside the fuselage before tightening the wing bolts. Your model should be flight-ready before balancing.

2) The recommended Center of Gravity (CG) location for your model is (80mm) back from the leading edge at the center of the wing.

3) When balancing your model, make sure it is assembled and ready for flight. Support the plane upright at the marks made on the wing with your fingers or a commercially available balancing stand. This is the correct balance point for your model.

\*If possible, first attempt to balance the model by changing the position of the receiver battery and receiver. If you are unable to obtain good balance by doing so, then it will be necessary to add weight to the nose or tail to achieve the proper balance point.

With the wings attached to the fuselage, all parts of the model installed ( ready to fly), and empty fuel tanks, hold the model at the marked balance point with the stabilizer level.

Lift the model. If the tail drops when you lift, the model is “tail heavy” and you must add weight\* to the nose. If the nose drops, it is “nose heavy” and you must add weight\* to the tail to balance.



1.

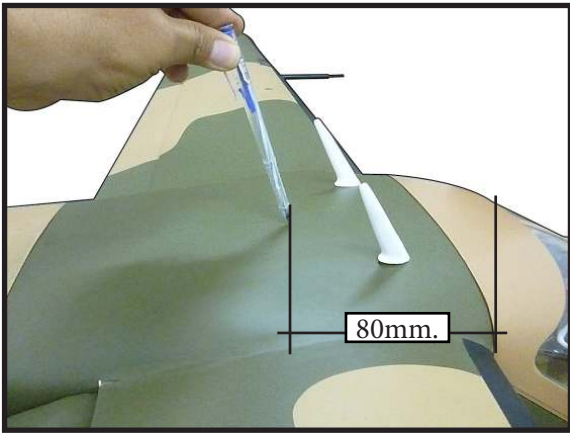

## CONTROL THROWS

### Ailerons:

High Rate :

Up : 25 mm

Down : 25 mm

Low Rate :

Up : 20 mm

Down : 20 mm

### Rudder:

High Rate :

Right : 25 mm

Left : 25 mm

Low Rate :

Right : 20mm

Left : 20 mm

### Elevator:

High Rate :

Up : 20 mm

Down : 20 mm

Low Rate :

Up : 15 mm

Down : 15 mm

### Flap:

Mid : 30mm

Full : 50 mm

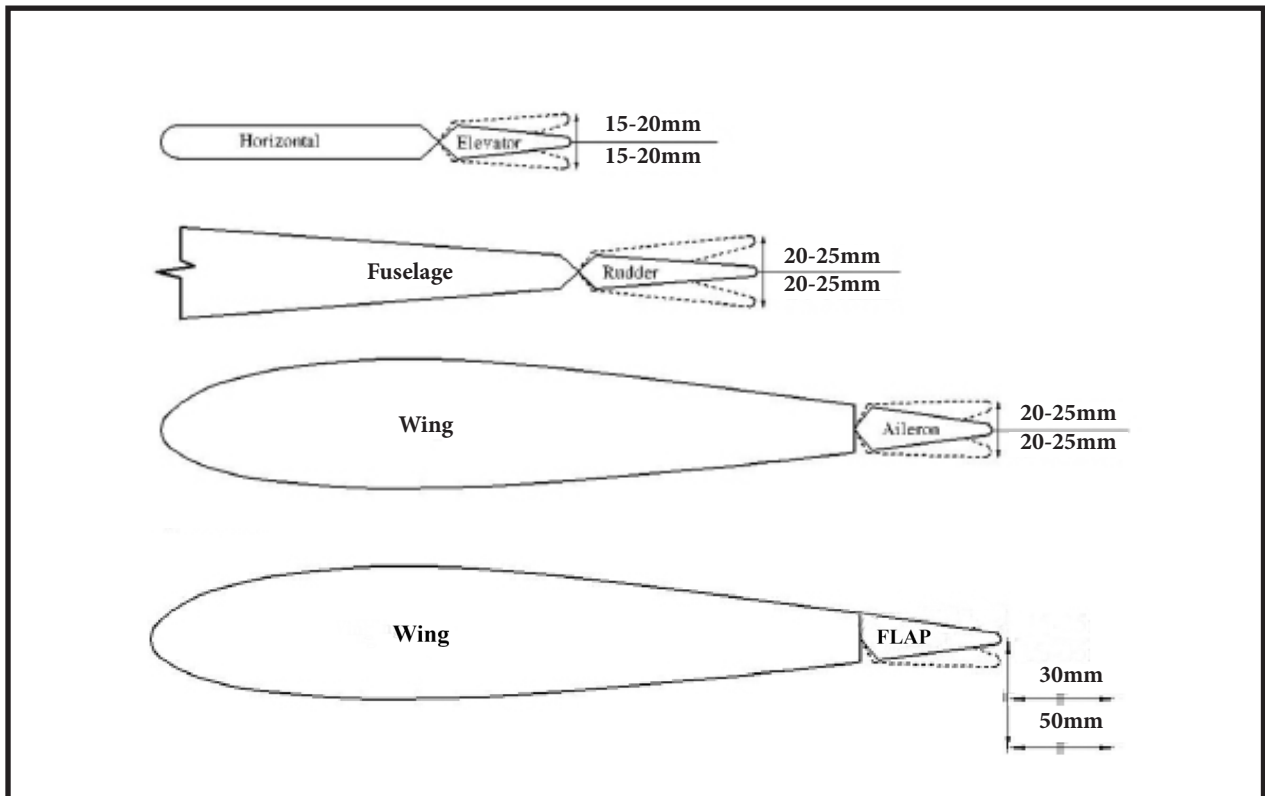

## FLIGHT PREPARATION

Check the operation and direction of the elevator, rudder, ailerons and throttle.

- A) Plug in your radio system per the manufacturer's instructions and turn everything on.
- B) Check the elevator first. Pull back on the elevator stick. The elevator halves should move up. If it they do not, flip the servo reversing switch on your transmitter to change the direction.
- C) Check the rudder. Looking from behind the airplane, move the rudder stick to the right. The rudder should move to the right. If it does not, flip the servo reversing switch on your transmitter to change the direction.
- D) Check the throttle. Moving the throttle stick forward should open the carburetor barrel. If it does not, flip the servo reversing switch on your transmitter to change the direction.
- E) From behind the airplane, look at the aileron on the right wing half. Move the aileron stick to the right. The right aileron should move up and the other aileron should move down. If it does not, flip the servo reversing switch on your transmitter to change the direction.

## PREFLIGHT CHECK

- 1) Completely charge your transmitter and receiver batteries before your first day of flying.
- 2) Check every bolt and every glue joint in the CESSNA 208 GRAND CARAVAN 85 INCH WINGSPAN 35-40CC to ensure that everything is tight and well bonded.
- 3) Double check the balance of the airplane. Do this with the fuel tank empty.
- 4) Check the control surfaces. All should move in the correct direction and not bind in any way.
- 5) If your radio transmitter is equipped with dual rate switches double check that they are on the low rate setting for your first few flights.
- 6) Check to ensure the control surfaces are moving the proper amount for both low and high rate settings.
- 7) Check the receiver antenna. It should be fully extended and not coiled up inside the fuselage.
- 8) Properly balance the propeller. An out of balance propeller will cause excessive vibration which could lead to engine and/or airframe failure.

*We wish you many safe and enjoyable flights*  
*with your* CESSNA 208 GRAND CARAVAN 85 INCH WINGSPAN 35-40CC.

---

*If you have any queries, or are interested in our products,  
please feel free to contact us*

**Factory :** 12/101A - Hamlet 4 - Le Van Khuong Street - Dong Thanh Ward -  
Hoc Mon District - Ho Chi Minh City - Viet Nam.

**Office :** 62/8 Ngo Tat To Street - Ward 19 - Binh Thanh District - Ho Chi Minh  
City - Viet Nam

**Phone :** 848 - 86622289 or 848- 36018777

**Website :** [www.SeagullModels.com](http://www.SeagullModels.com)

**Email :** [Sales@seagullmodels.com](mailto:Sales@seagullmodels.com)

**Facebook :** [www.facebook.com/SeaGullModels](http://www.facebook.com/SeaGullModels).