

Engine

DLE61

**使用说明书
USER MANUAL**

该发动机并非玩具，请特别注意安全，由此引起的所有安全问题我们将不予负责；为了您更好地使用该产品，请您在使用前仔细阅读说明书。

This engine is not toy. For your own safety, please read the manual carefully before operation. DLE is not responsible for all injuries result from the use.

一、安全 (SAFETY INSTRUCTIONS)

1、使用前请仔细检查螺旋桨、发动机架等相关部位，保证螺丝、螺母不松动，安装时一定要使用螺纹胶（如：LOCTITTE 242、243等）固定螺丝、螺母。安装螺旋桨不使用螺纹胶会导致固定螺丝被螺旋桨全部切断。

Before every use, check the engine assembly, propeller and airframe carefully for loose screws and nuts. Loctite(242,243) is strongly recommended on all the screws. Otherwise propeller could cut off the bolts during the flight.

2、请注意：如果要在试车台上磨合或测试发动机，必须有很好的减震装置，否则可能导致发动机部分零件的损坏，最好把发动机安装在飞机上进行磨合。

During the break-in process, engine must running with shock absorber installed. Or the engine will be seriously damaged by vibration.

3、发动机在运行时，任何人不许在螺旋桨旋转平面前的位置。
Always stand clear of and behind the propeller; never allow anyone including yourself, to be in front of or to the sides of the propeller when starting or running the engine. Anyone near the engine should wear protective eyewear. Do not wear loose clothing near the engine or propeller

二、发动机数据: (SPECIFICATIONS)

1、性能: (Performance)

6HP/7500rpm (6HP/7500rpm)

怠速: 1400 rpm/分钟 (Idle Speed: 1400rpm/min.)

拉力15Kg/海拔100米 (15Kg Static Thrust / 100 meters Altitude)

拉力13Kg/海拔1800米 (13Kg Static Thrust / 1800 meters Altitude)

适用螺旋桨规格: 22×10; 23×8; 23X10; 24X8

(The specification of the aircraft propeller): 22×10; 23×8; 23X10; 24X8

适用火花塞型号(the type of the sparking plug): NGK CM6

2、参数: (Parameter)

排量(Exhaust Amount): 60cm³

缸径×行程(diameter × stroke): 47mm×35mm

压缩比(Ratio of compression): 10.5: 1

润滑比(Ratio of lubricating capacity): 30:1

重量: 主机1270克+排气管110克+点火器 130克

Weight: Main engine – 1270g Exhaust pipe – 110g

Ignition equipment – 130g

3、点火器工作电压 (Ignition volt): 4.8V-14V

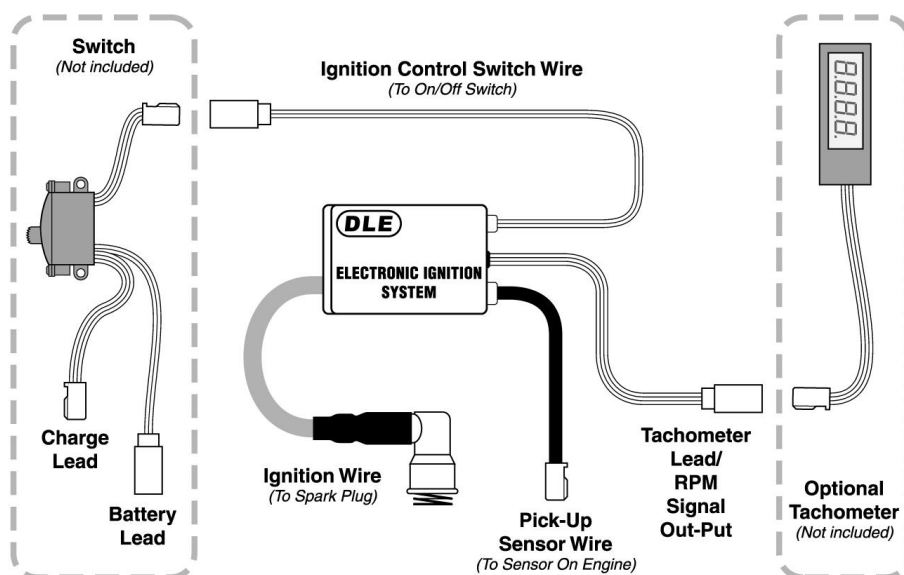

三、发动机的调整(ENGINE ADJUSTMENT)

1、每台发动机出厂时都经过了初步调整，用户可以直接使用。但各地区的海拔高度将会影响化油器的正常工作，化油器油针可能需要进行微调才能达到最佳的工作位置。Every engine has been adjusted to average mixture settings which will most likely allow the engine to start and run in most locations. However, as altitudes and barometric pressures vary by location, it is very likely that the carburetor mixture settings will need to be adjusted to obtain optimum performance.

2、功能及调整 (Functions and Adjustments)

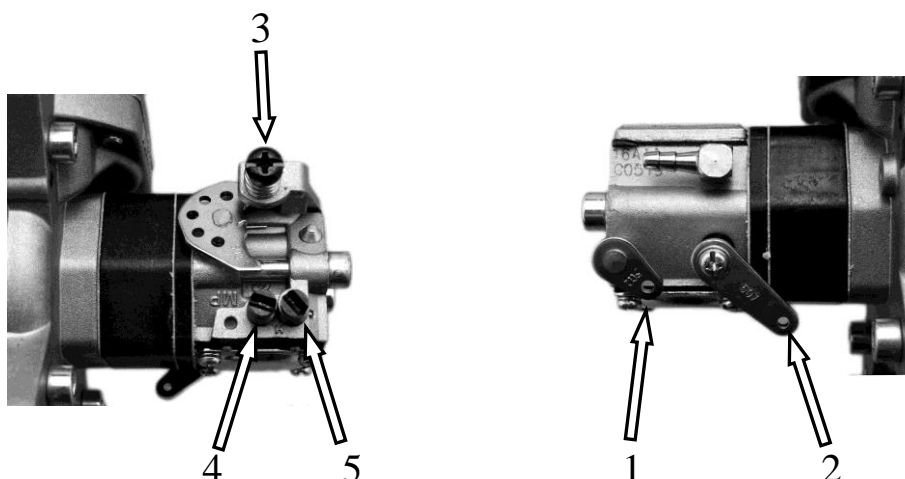

- (1) 风门，冷启动时使用(Choke Lever)
- (2) 油门(Throttle Lever)
- (3) 怠速调节螺丝(Idle Speed Adjustment Screw)
- (4) 低速油针(Low Speed Mixture Adjustment Screw)
- (5) 高速油针(High Speed Mixture Adjustment Screw)

调整：顺时针转动怠速螺丝3将增大怠速转速，同时要配合低速油针4一起调整，顺时针转动低速油针减少油量（一般是把油针拧到底再退回1.5圈）；高速油针5(退回1.5圈)最好使用转速表来调整，使发动机达到最高转速，加减速顺畅为最佳。

ADJUSTMENT: A general starting point is 1.5 turns out for the low speed needle (See No. 4), and 1.5 turns out for the high speed needle (See No. 5).

Adjust the High needle to peak rpm. If ever the engine slows or dies while at full throttle, the high speed mixture is likely too lean.

Adjust the Low needle until you achieve a smooth idle and a reliable transition to high throttle.

If the engine dies when the throttle is advanced, the mixture is likely too lean. If the engine stumbles when the throttle is advanced, the mixture is likely too rich.

- 调整化油器高速油针时请注意：混合气调整过稀将导致发动机严重过热和火花塞烧毁。大油门燃烧后火花塞的颜色应该是黄色,说明混合气浓度比较合适。混合气调整过浓时，特别是高速油针的调整，发动机快速收油门容易熄火。

Caution: Don't be tempted to run an overly rich mixture. A too rich mixture will only result in poor engine performance (engine easily off in a quick accelerating and decelerating process), pre-mature carbon buildup, a fouled plug and excessive exhaust residue. However, a lean mixture will also damage the cylinder and piston badly. After few times full throttle test and check the spark plug, it appears to be yellow if mixture had been set properly.

3、发动机的启动 (Start-up the engine)

- (1) 关闭风门，加大油门,打开点火电源.

Step 1: Close the Choke and turn on the ignition, advance throttle to full position.

(2) 用力转动螺旋桨，(最好用启动棒)直到发动机发出爆炸声.发动机会运转1-2秒而自动熄火。(首次启动或长时间不用可能需要转动多次螺旋桨)。

Step 2:, briskly flip the prop through compression until the engine fires and then dies. It may take a few more flips if this is first time to start the engine after being stored for a long period.

(3) 打开风门，油门开至怠速或比怠速稍大一点,启动发动机，进入正常工作状态。

Step 3: Open the choke and briskly flip the prop through compression, advance the throttle to very slightly above the idle position, the engine should start in just a few flips.

(4) 热车启动：打开风门，油门开至怠速或比怠速稍大一点，直接启动发动机。

Step 4: Open the choke, advance the throttle to very slightly above the idle position, turn on the ignition and briskly flip the prop through compression.

四、发动机的保养 (MAINTENANCE OF THE ENGINE)

1、请使用清洁的92#汽油，和机油的比例为30:1；禁止不同厂家、牌号的润滑油混合使用，否则将会引起化油器严重阻塞。

Please use the petrol 92#. The ratio of petrol and engine oil is 30:1; **Do not mixed up different brand of engine oil, carburetor could be seriously blocked**

2: 发动机的磨合：4000 rpm/min.磨合2小时。发动机长时间低速运行，可能导致火花塞积炭严重。

Breaking-in at 4000RPM/min for 2 hours. Running at low speed for too long might carbonize the spark plug.

3、随时检查油箱至化油器之间的管路，不许有漏气情况。

Always check the tube at fuel system, make sure there is no air leaking.

4、请特别注意：在一定周期内清洁化油器里面的燃油滤网，否则将引起油针调节失灵，发动机工作不稳等情况。

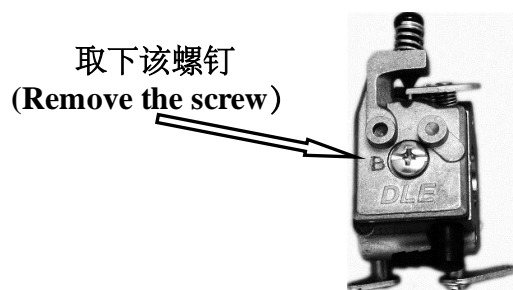

NOTICE: The carburetor fuel screen should be cleaned periodically also. Carefully remove the pump cover (inlet side of the carburetor), gasket and pump membrane. The screen will be visible and can be cleaned after careful removal.

联系我们/Contact us

电话(TEL): 4001006090

传真(FAX): 086-0873-6131518

销售 (Sale): 086-13529826090

Http: www.dlpower.net

E-mail: dle@dlengine.com

地址：中国云南省弥勒市弥勒工业区弥阳工业园

邮编：652300

Address: MiYang Industrial Park Mile Industrial District Mile City, 652300, Yunnan Province, PR China

弥勒浩翔科技有限公司
Mile HaoXiang Technology Co.,Ltd