

# Gemini 3018

## Redundant Power Supply Instruction Manual

### Product Features

- Dual battery (2S, LIPO) redundant input
- Linear regulated output capability up to 30A
- Dual S.BUS1/2 signal redundant input
- 18-channel PWM output and 2 HPB outputs
- Automatically synchronize output refresh rate with receiver
- Equipped with new FSS-5 fail safe electronic switch
- Supports high voltage output
- All aluminum alloy CNC housing
- Suitable for large gasoline models, jets and drones

### Dimensions

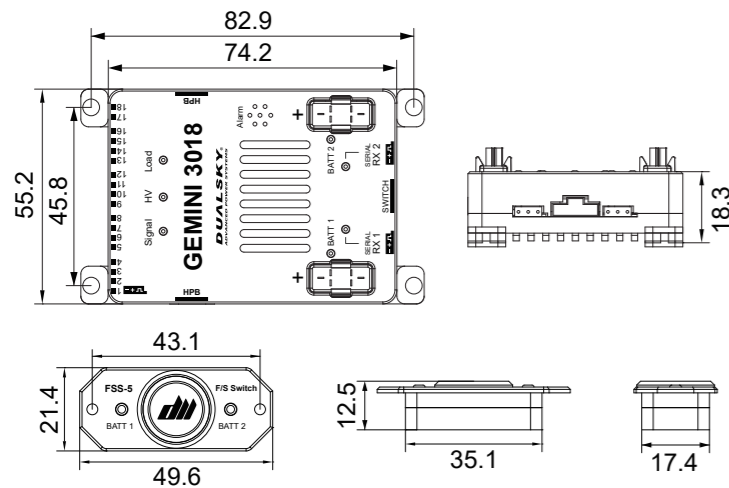

### Wiring Diagram

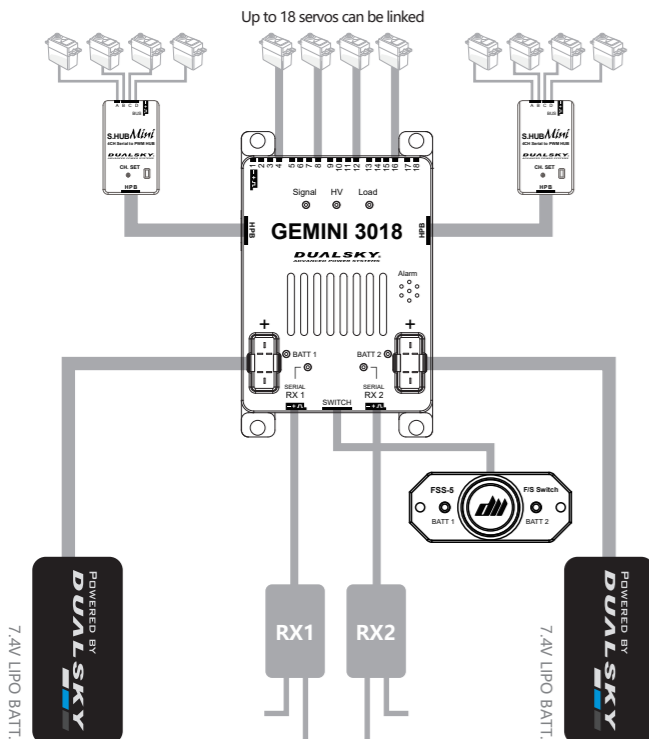

### Power source

- Gemini power supply is designed for 7.4V lithium polymer battery. Other types of power input are not recommended.
- Support dual-battery input. The redundant strategy is: The higher voltage battery will be chosen as the power supply.
- There is a LED next to the battery socket. When the capacity is 100%-80%, LED is blue; 80% to 50%, LED is green; 50% to 30%, LED is yellow; Capacity less than 30%, LED is red.
- When capacity of battery is less than 10%. The buzzer will beep. It will not stop before the shutdown, so that the pilot will pay attention to the low battery after landing.
- In the dual battery working mode, if one battery is disconnected, the system works uninterruptedly, and the LED and buzzer alarm are triggered at the same time. The alarm will not be stopped this round.
- Gemini also supports single battery working mode.
- When the battery is connected to Gemini, there is a milliamp power consumption even if it is turned off. If it is not used on the same day, please disconnect batteries from Gemini.
- If battery socket on main body is often plugged and unplugged, there is a risk of damage. It is recommended to connect the battery with the adapter cable.

### Signal source

- Gemini supports SBUS1 or SBUS2 serial bus input protocol and supports up to 18 channels of PWM output. How many channels are included in the bus, please refer to the receiver's manual.
- Supports dual signal input. The redundant policy is: RX1 is the main receiver, and RX2 is the auxiliary receiver. When the RX1 signal quality is abnormal or the signal is lost, switch to RX2. When RX1 is recovered, switch back to RX1.
- Signal sources have their own LED indicators. No signal, LED is off. When signal is normal, LED is always on; if the signal is abnormal, the LED blinks slowly; if signal lost and recovered (for example, the wire contact problem), the LED blinks quickly.
- In the dual receiver working mode, one signal is lost, the system works uninterrupted, and the buzzer alarm is triggered at the same time.
- Gemini also supports single receiver working mode.
- Gemini provides the same voltage to the receiver and output sockets, please ensure that the receiver can work at this voltage.
- The power supply capacity of the signal port is about 3A. It can power some servos or devices, but it is not recommended.
- Different types of receivers are not recommended for mixing use (eg 6208SB + 6108SB), although this works.

### Switch

Gemini is equipped with FSS-5 electronic switch. Press and hold for 3 seconds to turn on, press and hold 3 seconds to shut down. After power is turned on, the Gemini will perform a self-test. In the single-power mode, the buzzer will beep once, and in the dual-battery mode, two beeps will sound. The switch has a Fail Safe function, any damage or disconnection will not cause the main body powered off. There are dual battery status LEDs on the switch, which are synchronized with the body battery indication. Please refer to the previous section for details.

### Servo outputs

Gemini decodes up to 18 PWM channels, of which 1-16CH are proportional channels and 17CH&18CH corresponds to DG1 & DG2 switching channels. If input source is less than 18 channels, the excess channels have no output signal. The maximum peak current of each socket is 5 amps, and 2.5 amps continuous. Excessive current will damage the socket. The output refresh frequency is synchronized with S.BUS frame rate. In the 18-channel FASST/FASSTest(MULTI) mode, the frequency is around 70 Hz; in the 12-channel FASSTest mode, the frequency is 170 Hz (only digital servo can be used at this frequency).

### HPB (High Power Bus)

Two HPB ports are equipped on both sides of the Gemini, which have the following characteristics:

- Each HPB port has a current output capability of 30A.
- After re-encoding the channel data, HPB outputs the S.BUS1 signal.
- It can be directly connected to the S.BUS1/S.BUS2 servo or works with the Dualsky S.HUB MINI.

### Status indicator

There are 3 indicators near the output area, as shown on the right. After power on, the details are as follows:

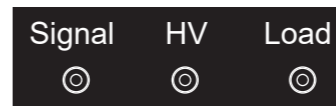

- **Signal** signal comprehensive indication
- **HV** high voltage output indication
- **Load** load indicator

Blue solid, when RX1&RX2 signals are normal.  
Green solid, when signal source switching occurred;  
Yellow solid, when one signal is lost or in one receiver mode  
Red solid, when two signals are abnormal at the same time.  
Alarm triggered. Nonstop this round.

If output voltage is 6.0V, the light is off; 6.6V or 7.4V light is on.  
Please pay attention to use high voltage servo, receiver and equipment when the voltage is 6.6V or 7.4V.

Reflects the internal temperature of the host, initially the light is blue, above 50 degrees green, above 70 degrees yellow, above 80 degrees red and triggers buzzer alarm.

### Voltage regulation and capability of output current

Thanks for linear regulation technology. Gemini provides up to 30 amps of "pure" current (low ripple and high load rate) for remote control systems. The output voltage can be set on the side of the body. At different voltages, the capability of output current is as follows:

7.4V - 30A continuous output (HV indicator is on)

6.6V - 20A continuous output (HV indicator is on)

6.0V - 15A continuous output (HV indication is off)

### Data telemetry

Gemini provides 3 amps for the receiver, and the RX1 main receiver can directly connect to various sensors if it has a telemetry function. Regulated voltage is also automatically returned, no additional wiring is required. It is recommended to set a return voltage alarm on transmitter to improving flight safety. For example: when 7.4V is regulated, the transmitter can set a 7.3V alarm prompt. When the battery voltage drops below 7.5V, the regulated voltage cannot maintain 7.4V, it decreases as the battery voltage decreases. Then transmitter's alarm is triggered during flight. Gemini's battery indicators should be solid yellow.

### Installation

- The Gemini body has four mounting holes and is fixed to the body with screws.
- When Gemini 3018 is used in a strong vibration environment, it is necessary to install shock absorbing rubber fittings.
- The upper and lower housing of Gemini are involved in heat dissipation and cannot be covered or bonded to model.
- The switch is designed to facilitate screws to be fixed on the outside of the fuselage or on the equipment board.
- The body and switch are not waterproof.

### Disclaimer

Thank you very much for using this product. Please use this product strictly in accordance with the manual. We do not assume any liability arising out of the use of this product or illegal modification or improper operation, including but not limited to indirect damage or joint liability, the maximum compensation is not higher than the price of the product itself. By using this product, you agree to the terms of this statement.

### Warranty

Dualsky electronic products warranty is for 12 months from the date of sale. If you want to claim during the warranty period, please contact your dealer immediately. The cashier receipt at the model store can prove whether the goods are under warranty. Please note that the warranty period will not be extended under any circumstances. Warranty service is provided free of charge for any functional defects, production failures or material defects during the warranty period. We will not accept any further claims, such as the user is responsible to pay the return shipping cost of the indirect damaged goods, we will pay for the return shipping cost to the user. If the shipping costs are not prepaid, we will not accept the goods. We do not accept the damage caused by transportation and do not make up for the loss of transportation. We recommend you to buy transportation insurance and send your equipment to the service center. We can process your claim if the following conditions are met:

- Provide cashier receipts
- Operate the equipment correctly according to the instructions
- Use recommended power supplies and accessories
- The damage is not caused by water, reverse polarity, or over load.
- Please provide a concise and accurate description of the fault to help us solve the problem