

U M S

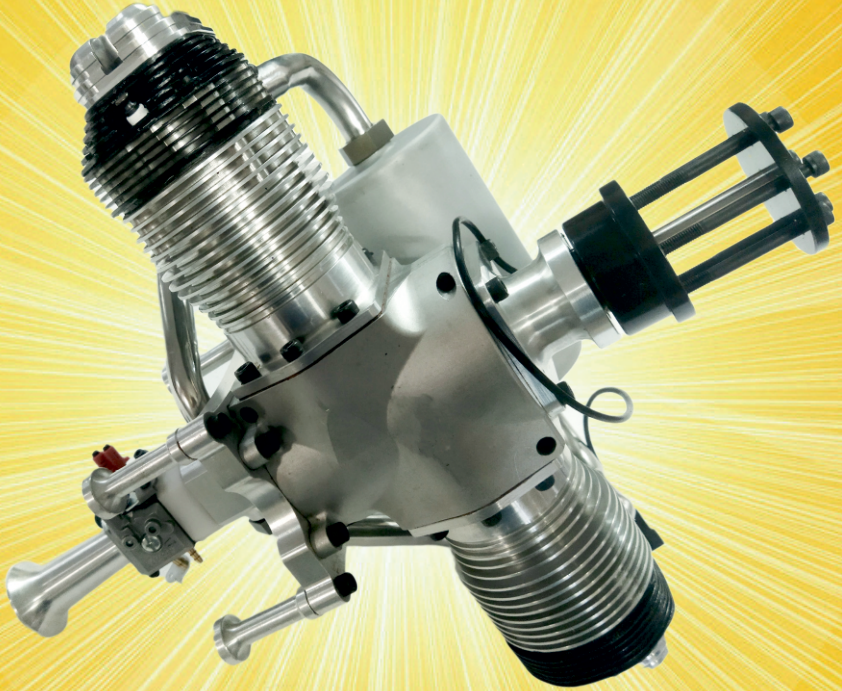

200cc

BOXER

BOXER 200cc

PRODUCT SPECIFICATIONS

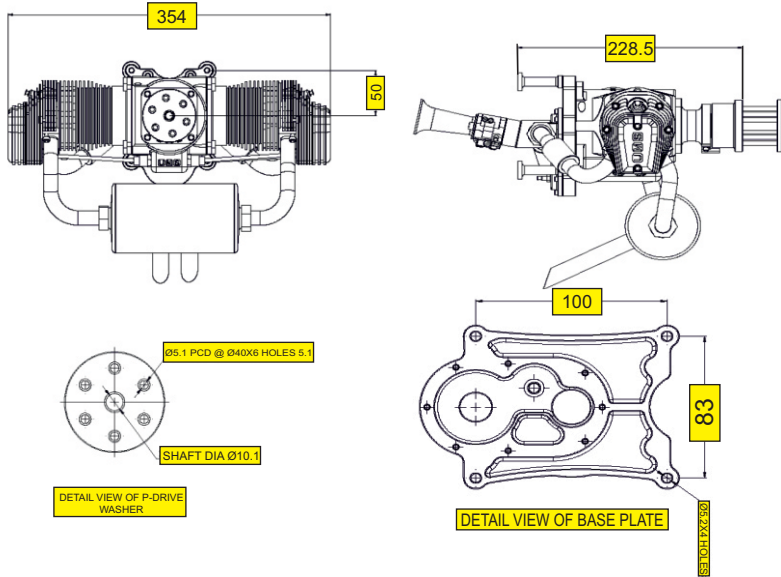

TECHNICAL SPECIFICATIONS

TYPE	SPARK IGNITION
CYLINDER	TWO CYLINDER
CAPACITY	200CC
BORE	52MM
STROKE	48MM
THRUST(Approx)	25 kgf @ 32x14 Menz prop
ROTATION(RPM)	1000 - 4600
WEIGHT	5.95KG (INC SILENCER & COIL)
ENGINE LENGTH	228.5mm
PROPELLER RECOMMENDED	32X14 (MENZ), 33X14 (SEP)
IGNITION	FRONT SIDE MAGNET
ENGINE FUEL	BENZIN
CARBURETOR	WT225

UMS Technologies Private Limited

"Gopal Bagh", 1062, Avinashi Road, Coimbatore - 641 018. INDIA

Ph. : +91 422 2243439 (5 Lines) ♦ Fax : +91 422 2242760 ♦ E-mail : support@umstech.in

Website : www.umstech.in