

Futaba R334SBS

T-FHSS SR/T-FHSS-2.4GHz System
Diversity antenna
S.BUS2, 4-Channel Receiver for Model Car



INSTRUCTION MANUAL

Thank you for purchasing the R334SBS receiver. The R334SBS is designed for use with the Futaba T-FHSS SR/T-FHSS system transmitter. The R334SBS receiver has adopted the newly developed high-speed response system "T-FHSS SR".

Note: The R334SBS is compatible with the T-FHSS SR/T-FHSS system transmitters. The receiver type setting of the transmitter is set in T-FHSS SR/T-FHSS.

***Futaba T-FHSS system does not work with current Futaba S-FHSS/FHSS/FASSTest/FASST/T-FHSS Air system.**

In case of T-FHSS SR

- **SR servo**
The servo corresponding to the SR mode is needed. The servo type setting of the transmitter is set in SR mode.
- **SR mode ON/OFF**
ON/OFF of SR mode can be established according to each channel by a transmitter setting. An OFF channel can use a normal servo/ESC.
- **Telemetry function**
Telemetry function cannot be used for the T-FHSS SR. Do not use the S.BUS2 port in SR mode.
- **Mode Change**
To change the system mode, select the system mode (T-FHSS or T-FHSS SR) of the transmitter first. Then, making a link between the transmitter and the receiver to build up the radio linkage.

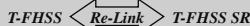

In case of T-FHSS

- **Telemetry system**
With the telemetry system, the running status can be displayed at the transmitter. By connecting S.BUS sensors that are separately sold into the S.BUS2 port of the receiver (R334SBS), the transmitter will be possible to show the telemetry data on its display.
- **Normal mode/High Speed mode**
The "Normal mode" accepts any type of servos or the peripheral. The "High Speed mode" only accepts the digital servos, including BLS series, and most peripheral equipments such as the brushless ESCs. Please pay special attention to the information contained within this manual and transmitter's manual in order to have a pleasant running experience.
Operating Precautions (T-FHSS):
Once the R334SBS detects the T-FHSS normal mode or T-FHSS high speed mode, the detected mode is locked as long as the power is ON. When need to change the mode, please cycle power.

Usage condition on "T-FHSS SR mode"

CAUTION

- When using the T-FHSS SR mode, use an SR mode servo. Normal servos cannot be used.
- The use of normal servos may cause servo trouble.

Usage condition on "T-FHSS High Speed mode"

CAUTION

- When using the high-speed mode, use a Futaba digital servo (including brushless servo). Analog servos cannot be used.
- The use of analog servos may cause servo trouble.

WARNING

- After the linking is done, please cycle receiver power and check if the receiver to be linked is really under the control of the transmitter to be linked.
- Do not perform the linking procedure with motor's main wire connected or with the engine operating as it may result in serious injury.

WARNING

- NEVER** remove the case to avoid the unexpected malfunction. When removing a case from the double-stick tape, maintain the bottom case.
- NEVER** use dry batteries for the power supply of the R334SBS as this may cause difficulties with the receiver's operation.
- Wrap the receiver with something soft, such as foam rubber, to avoid vibration. Do not splash water over the receiver.
- Since the receiver generates a certain amount of heat, install in a place with good ventilation.
- Do not put any conductive equipment/sticker on the antenna part. (Receiver top)
- Otherwise, the operating range may become shorter.

The Example of Connection

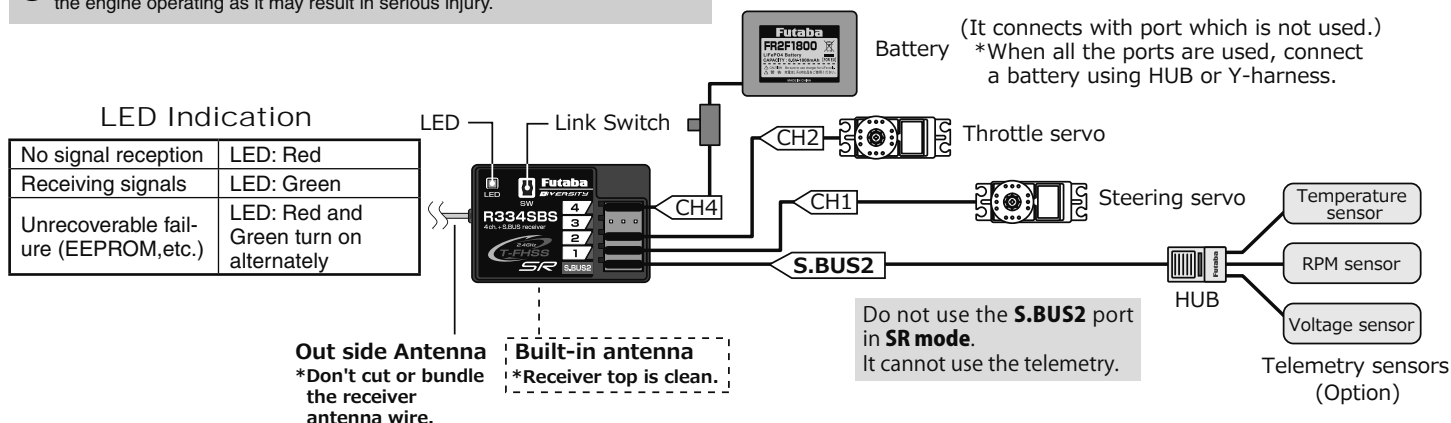

Link Procedure

Each transmitter has an individually assigned, unique ID code. In order to start operation, the receiver must be linked with the ID code of the transmitter with which it is being paired. Once the link is made, the ID code is stored in the receiver and no further linking is necessary unless the receiver is to be used with another transmitter.

- Place the transmitter and the receiver within half a meter of each other.
- Place the transmitter into the linking mode and turn on the receiver.
- During countdown, push the receiver tact switch for approximately 2 seconds.

The LED will begin to blink red. After the receiver LED switches from blinking red to green → green (red) steady light, If the transmitter and receiver are linked normally, set the power switch to the OFF position and then return it to the PWR ON position. If the receiver LED lights green, linking was successful. (T4PLS, T4GRS : set the power switch to the OFF position and then return it to the PWR ON position.) Actually check servo operation.

- * Please refer to the table below for LED status and receiver condition.
- * Refer to user manual of the transmitter, to change your transmitter in "Link" mode.
- * If there are many T-FHSS systems turned on in close proximity, your receiver might have difficulty establishing a link to your transmitter. This is a rare occurrence. However, should another T-FHSS transmitter/receiver be linking at the same time, your receiver could link to the wrong transmitter. This is very dangerous if you do not notice this situation. In order to avoid the problem, we strongly recommend you double check whether your receiver is really under control by your transmitter.

R334SBS Specifications:

- (T-FHSS SR/T-FHSS system, S.BUS2, 4-channel receiver)
- Receiving on 2.4GHz band
- System: T-FHSS SR/T-FHSS system
- Power requirement Operating voltage: 3.7V-7.4V
- F/S and Battery F/S function: It is set according to the transmitter used.
- Battery F/S voltage: Set it with the transmitter arbitrarily.
- Size: 1.33x0.88x0.44" (33.9x22.3x11.3mm)
- Weight: 0.26oz. (7.5g)

Compliance Information Statement (for U.S.A.)

This device, trade name Futaba Corporation, model number R334SBS, complies with part15 of the FCC Rules. Operation is subject to the following two conditions:

- (1) This device may not cause harmful interference, and
- (2) This device must accept any interference received, including interference that may cause undesired operation.

CAUTION:

- To assure continued FCC compliance: 1. Any changes or modifications not expressly approved by the grantee of this device could void the user's authority to operate the equipment.
2. This equipment complies with FCC radiation exposure limits set forth for an uncontrolled environment. This equipment should be installed and operated with minimum distance 20cm between the radiator & your body.

The responsible party of this device compliance is:

Futaba Service Center
 3002 N Apollo Drive Suite 1, Champaign, IL 61822 U.S.A.
 TEL (217)398-8970 or E-mail: support@futaba-rc.com (Support)

