

It is of vital importance, before attempting to operate your engine, to read the general 'SAFETY INSTRUCTIONS AND WARNINGS' in the following section and to strictly adhere to the advice contained therein.

• Also, please study the entire contents of this instruction manual, so as to familiarize yourself with the controls and other features of the engine.

SAFETY INSTRUCTIONS AND WARNINGS ABOUT YOUR O.S. ENGINE

Remember that your engine is not a "toy", but a highly efficient internal-combustion machine whose power is capable of harming you or others, if it is misused or abused. As owner, you, alone, are responsible for the safe operation of your engine, so act with discretion and care at all times. If at some future date, your O.S. engine is acquired by another person, we would respectfully request that these instructions are also passed on to its new owner.

■ The advice which follows is grouped under two headings according to the degree of damage or danger which might arise through misuse or neglect.

⚠ WARNINGS

These cover events which might involve serious (in extreme circumstances, even fatal) injury.

⚠ NOTES

These cover the many other possibilities, generally less obvious sources of danger, but which, under certain circumstances, may also cause damage or injury.

⚠ WARNINGS

 Never touch, or allow any object to come into contact with the rotating propeller and do not crouch over the engine when it is running.



 Gasoline is poisonous. Do not allow it come into contact with the eyes or mouth. Always store it in a clearly marked container in a cool and dark place and out of the reach of children. There is a possibility that it may damage your health.

 Gasoline is highly flammable. Keep it away from an open flame, excessive heat, sources of sparks, or anything else which might cause it to ignite. Do not smoke or allow anyone else to smoke near to it.

■ ABOUT THE ENGINE

- How to adjust the carburetor of this engine is completely different from that for the conventional glow engine's carburetor. Please study the CARBURETOR ADJUSTMENT section so as to familiarize yourself with the controls and other features.
- This engine is designed for experienced fliers. Beginners and newcomers should not use this engine.
- The engine unit, silencer and carburetor are specially designed.
- The normal rotation direction of the engine is counterclockwise facing to the propeller.
- It offers broad power characteristics suitable for sport flight as well as acro flight.
- The large and dense cooling fins ensure sufficient cooling against overheating.
- The specially designed ignition module "IG-06" is equipped with a micro computer and designed not to operate below 120 rpm.
- The supplied E-4040 silencer develops very efficient silencing.

STANDARD ACCESSORIES

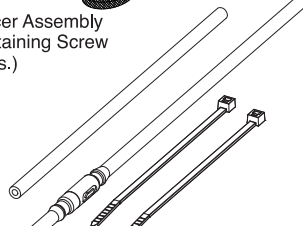
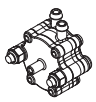
- Spark Plug CM-6 
- Ignition module Assembly (IG-06) 
- E-4040 Silencer Assembly Silencer Retaining Screw (M4x40 2pcs.) 
- Pump Set 

 Carry out the mixing of the gasoline and oil outdoors or in a well ventilated place away from any source of fire to prevent the possibility of a fire.

 Refill the fuel tank only after the engine is well cooled down, or there is a danger of fire.

 Model engines generate considerable heat. Do not touch any part of your engine until it has cooled. Contact with the muffler (silencer), cylinder head or exhaust header pipe, in particular, may result in a serious burn.

• Observe the laws and regulations in each country and district concerning the usage, transportation and storage of gasoline. Ask details at fire station in each district.

• Never operate your engine in an enclosed space. Model engines, like automobile engines, exhaust deadly carbon-monoxide. Run your engine only in an open area.

• Do not operate the engine nor model alone, or there is a possibility of injury.

⚠ NOTES

- Any propeller requires utmost attention to handle. Be sure to follow the instruction manual supplied with a propeller.
- This engine was designed for model aircraft. Do not attempt to use it for any other purpose.
- Start the engine only after installing it in the model. Do not start the engine before installing it in the model, or there is a possibility of injury.
- Be sure to use an effective silencer (muffler). Frequent exposure to an open exhaust may eventually impair your hearing. Such noise is also likely to cause annoyance to others over a wide area.
- Mount the engine in your model securely, following the manufacturers' recommendations.
- For their safety, keep all onlookers (especially small children) well back (at least 10 meters) when preparing your model for flight.
- When checking a spark plug with the power source on, do not hold the plug, plug cap, high tension cord, or you will get a shock.
- Install a top-quality propeller of the diameter and pitch specified for the engine and aircraft.

Notice on 61H carburetor clogging

Gasoline engine carburetors generally have narrower fuel passages for better fuel mileage than glow engines. As a result, the passages clog easily if a fuel filter is not used. You should insert a gasoline-resistant fuel filter — finer than #200 mesh — between the fuel tank and the engine (if a T-shaped tank nipple is used, place the filter between the nipple and the engine). Gasoline fuel filter S (code#7830000) is equipped as a standard accessory between the pump and carburetor. When filling your fuel tank from a gasoline container, always use the O.S. Super Filter L (part #72403050) to prevent dust from entering the tank. A clogged carburetor can cause inconsistent running, stalling, and overheating. If your carburetor becomes clogged, it must be disassembled and cleaned. When taking apart the carburetor, remember the assembling order. Be careful not to lose small internal parts. If you're not confident performing this type of maintenance, take the engine to the hobby shop where you purchased it or send it to the service center of your country's O.S. distributor.

■ ENGINE PARTS NAME

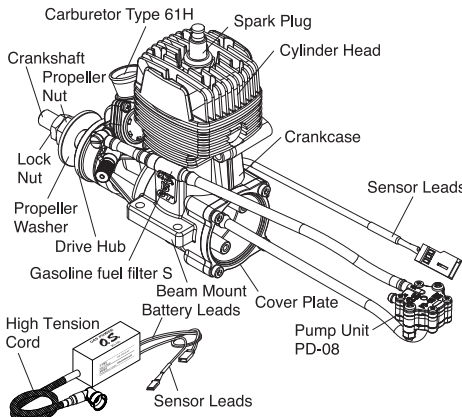

• Discard any propeller which has become split, cracked, nicked or otherwise rendered unsafe. Never attempt to repair such a propeller: destroy it. Do not modify a propeller in any way.

• Install the propeller on the shaft so that the curved face of the blades faces forward — i.e. in the direction of flight. Firmly tighten the propeller washer and propeller installing screws using the correct size wrench. Always check the tightness of propeller installing screws and retighten them, if necessary, before starting the engine. Also, check the tightness of all the screws and nuts before restarting the engine.

• Always check the throttle linkage. If it is disconnected, throttle action becomes uncontrollable, which may result in a serious accident.

• Take care that loose clothing (ties, shirt sleeves, scarves, etc.) do not come into contact with the propeller. Do not carry loose objects (such as pencils, screwdrivers, etc.) in a shirt pocket from where they could fall through the propeller arc.

• Use an electric starter for this engine. The wearing of safety glasses is also strongly recommended. If you try hand starting, be sure to use a chicken stick or heavy glove. Never attempt to start the engine with a bare hand.

• Be sure to carry out adjustments of the high speed needle and low speed needle after stopping the engine.

• Do not start your engine in an area containing loose gravel or sand. The propeller may throw such material in your face and eyes and cause injury.

• If you have to carry the model to the take-off point with the engine running, be especially cautious. Keep the propeller pointed away from you and walk well clear of spectators.

• Switch off the ignition module to stop the engine or fully close the throttle valve via the transmitter to shut off the fuel supply. Otherwise there is a possibility of injury.

• Immediately after the engine is stopped, the engine may start with a crank even when the igniter switch is off. Do not crank the engine, or there is a possibility of injury.

• Be sure to install an externally operable switch for the ignition system battery to stop the engine if it started unintentionally with the radio transmitter turned off or there is the possibility of injury.

• Connect the throttle linkage so that the engine can be stopped via radio operation.

■ INSTALLATION

• It is suggested to use as heavy and rigid as possible engine mounting for highest performance and safe running. Install the engine on a mount using at least 3mm steel screws, such as Allen type, with locknuts, for bolting the engine to the bearers.

• Also, use the Nord Lock Washers (optional extra) and other anti-loosening washers or apply locking agent.

• Be sure that there is sufficient air intake and outlet area on the model for engine cooling to avoid overheating. (Pay careful attention to the cooling since a gasoline engine generates more heat than a glow engine.)

■ INSTALLATION OF SPARK PLUG

Install the supplied spark plug firmly on the engine with a commercially available 14mm deep socket wrench.

■ INSTALLATION OF SILENCER

Secure the silencer to the engine by means of two retaining screws supplied after the engine is securely mounted on a model.

The exhaust outlet of the silencer can be rotated by 90 degrees in the following manner.

1. Loosen the locknut of the silencer and assembly screw.
2. Set the exhaust outlet at the required position by rotating the rear part of the silencer.
3. Re-tighten the assembly screw, followed by the locknut.

It is recommended to seal the fitting faces of engine exhaust and silencer with liquid gasket. Gasket at the joint part of the silencer will lose its sealing effect in a long time running. In this case, replace the gasket or apply liquid gasket to the joint.

■ FUEL TANK & LINES

• Use a tank designed for gasoline. (Tanks designed for glow fuel use a rubber cap which is deteriorated by gasoline.)

• A 200cc tank will provide 12 to 13 minutes flight. (With full throttle, it will provide 8 to 10 minutes flight.)

• Install a commercially available gasoline fuel filter between fuel tank and carburetor. (Clean the filter from time to time.)

- For plumbing use TYGON® F-4040 (Yellow color) or strong nitrile rubber of more than 2.4-3.2mm ID and 4.8-6.4mm OD. Replace tubing periodically as it becomes hardened. (Replace tubing inside the fuel tank every six months.)
- Use fuel line keepers of stainless wire, etc. at the end of the tubing to prevent the tubing from coming off.
- This engine does not require a muffler pressurized fuel system but be sure to provide an air vent.
- Be sure to install only one in-line fuel filter between the tank and carburetor to prevent foreign matter in the tank from entering the carburetor. Clean the filter periodically.

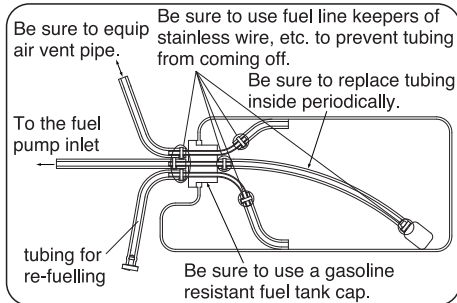

■ CARBURETOR PARTS NAME

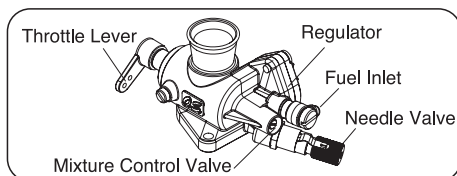

Two adjustable controls are provided on this carburetor.

- **The Needle-Valve**
For adjusting the mixture strength when the throttle is fully open Needle-valve adjustment effect the mixture strength at round mid speed.
- **The Mixture Control Valve**
For adjusting the mixture strength at part-throttle and idle speed, to obtain steady idling and smooth acceleration to mid speed.

Please note with this carburetor, needle-valve adjustment does not effect the mixture control valve adjustment but the mixture control valve adjustment effects the needle-valve adjustment. Therefore, it is required to adjust also the needle-valve when the mixture control valve is adjusted. Mixture control valve is pre-set at nearly best position when the engine leaves the factory. Therefore, it is not necessary to adjust the mixture control valve until running-in is completed.

■ CARE OF FUEL PUMP & REGULATOR

- NEVER disassemble the fuel pump or pressure regulator. Their original performance may not be restored after reassembly.
- DO NOT allow foreign matter to enter the fuel system. Dirt inside the pump or regulator, no matter how small, may obstruct the flow of fuel and prevent these components from working properly.
- NEVER insert anything into the inlet or outlet nipples in an attempt to clear a suspected obstruction.

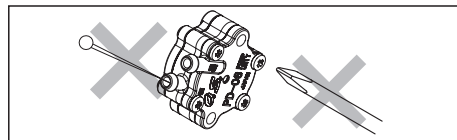

- DO NOT obstruct the small rectangular hole at the bottom of the regulator, nor the regulator will not function correctly.

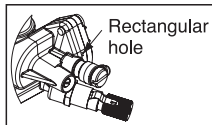

- ALWAYS use fuel filters. Keep the fuel tank scrupulously clean and filter all fuel as it enters the tank (e.g. via an O.S. 'Super-Filter' Code No.72403050) and use a good quality in-line filter between the tank and pump. Remember to inspect filter screens at regular intervals and rinse clean as necessary.
- NEVER use kerosene, thinner or any organic solvent for cleansing the pump. Rubber parts will be ruined by these materials. Use only alcohol (methanol) or gasoline.

■ HOW TO CONNECT THE PD-08 PUMP

1. Connecting the pump to the engine

Connect a TYGON tube to the center nipple of the pump with an INSULOK firmly.
Connect the outlet nipple of the pump and the carburetor fuel inlet with the TYGON tube with a fuel filter. There is an arrow sign on the fuel filter, which indicates the fuel flow to the carburetor. Refer to the drawing of ENGINE PARTS NAME.

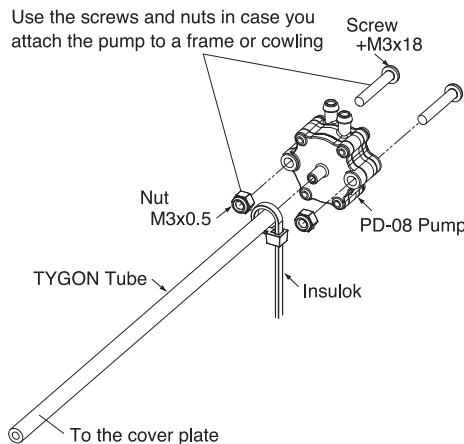

2. Attaching the pump

If you attach the pump to a frame or cowling, the existing M3 x 18 screws might not be long enough. You may need extra M3 screws.

You can also choose not to attach the pump in the fuselage. In this case, wrap it with foam or sponge so it will not move around. Also be sure to bind the pump itself tightly with the existing screws and M3 nuts. If you don't, fuel may leak from the pump.

Heat transferred to the PD-08 pump during engine operation may create bubbles in the fuel tubing between the pump and carburetor. The bubbles will prevent the engine from performing properly. Even if the air temperature is relatively low, heat can be transferred to the pump due to your cowling design. If this happens, you can correct it by relocating the pump behind the fire wall or outside the cowling to isolate it from the heat.

■ IGNITION MODULE

■ Major specifications

- Consumption current is 400mA/6,000rpm. User a power source of more than 1000mAh capacity.
- The ignition module is set not to operate below 120rpm for safety.
- The voltage of power source is 4.8~8.4V (rated). (Ni-Cd, Ni-MH 4~6 cells, Li-Po, Li-Fe 2 cells)

■ Installation

- Install the ignition module taking sufficient anti-vibration measures.
- Install the ignition module at least 100mm away from the engine and in a place where there is airflow so that engine exhaust heat and radiation heat may not affect it's operation.
- Do not share the power source with receiver and use a separate power source.
- Equip an ON/OFF switch between the ignition module and its power source and install it in a place where can be operated from outside the model.
- Install the ignition module and its power source as far as possible away from the servos and receiver power source.
- Connect the sensor leads of the igniter module (while, red, black three parallel wires) to the sensor leads from the engine.
- Connect the battery leads of the igniter module (red, black two parallel wires) to the power source.
- Make sure the jackets of high tension cord does not touch the engine and cowl to avoid accidental short circuit.
- Install the plug cap on the plug securely.

■ Precautions

- Do not disassemble the ignition module and plug cap. (The ignition module is irreparable. Replace it when necessary.)
- Be careful not to mount the ignition module so that it can be hit by water, gasoline or exhaust.
- Avoid using the engine when the external temperature is over 40 C.
- Do not move the rpm sensor as it is placed at it's optimum position, otherwise the engine will not run properly.
- Do not pull on the high tension cord to remove the plug cap, or the wire will break. Be sure to hold the plug cap to remove it. Be careful not to damage your fingers while removing it.
- Do not connect nor disconnect the rpm sensor with the ignition module on, or there is a possibility it will fire and the engine start.
- Check the ignition module for spark when installing the plug cap on the plug and be careful about getting a shock. Make sure there is no flammable material or gasoline vapors near by that could ignite.
- Do not turn the propeller with the ignition module on, or there is a possibility the engine will start.

■ THROTTLE LINKAGE

Before connecting the throttle to its servo, make sure that the throttle arm and linkage safely clear any adjacent part of the airframe structure, etc., as the throttle is opened and closed. Connect the linkage so that the throttle is fully closed when the transmitter throttle stick and its trim lever are at their lowest settings and fully open when the throttle stick is in its fully-open position. Carefully align the appropriate holes in the throttle arm and servo horn so that they move symmetrically and smoothly through their full travel.

■ PROPELLER

The choice of propeller depends on the design and weight of the aircraft and on the type of flying in which you will be engaged. Determine the best size and type after practical experimentation. As a starting point, refer to the props listed in the table shown below. Slightly larger, or even slightly smaller props than those shown in the table may be used, but remember that propeller noise will increase if blade tip velocity is raised due to high rpm or if a larger diameter/lower pitch prop is used. Be well aware that the propeller rotating arc will increase when using a larger propeller with this engine. Carry out the needle adjustments only after stopping the engine. Do not allow your face or hands to come close to the rotating prop.

Type	Size (DxP)		
Sport/Acro/Scale	13x8-11	14x8-10	15x-8

Warning:

Make sure that the propeller is well balanced. An unbalanced propeller and/or spinner can cause serious vibration which may weaken parts of the airframe or affect the safety of the radio-control system. Do not use any propeller which has become split, cracked or nicked even very slightly, or received strong impact even if no apparent damage is visible.

Since the GT15 is intended to be started with an electric starter, the addition of a spinner assembly for centering the starter sleeve is desirable. Special propeller locknut sets are available for use with spinners. Use a good quality well balanced spinner, enclosing the propeller boss. Make sure that it is of precision-made and sturdy construction so that the spinner shell cannot loosen when the starter is used. Make sure the spinner notches do not interfere the propeller. If they do, cut the notches to clear.

■ MIXING OF OIL

- Use regular gasoline. (No need to use high octane gasoline.)
 - Alcohol based glow fuel cannot be used in this engine. Not only will the engine not work properly but the internal carburetor plastic parts will be damaged.
 - Use high quality commercially available 2 stroke engine oil.
 - Follow the oil manufacturer's recommendations concerning the mixture ratio of gasoline and oil. If there is no recommendation, mix with a 25~30:1.
- We have checked the following oils with the mixture of 50:1.**
KLOTZ ModelLube®
AMSOIL Saber
Zenoah Genuine FC Class
Concerning the mixture ratio for running-in, follow the instructions in the RUNNING-IN section.

- With a gasoline engine, passages in the carburetor are narrower than that of a glow engine, and therefore very sensitive against foreign matter such as dust. It is suggested to use optional accessory Super Filter L (Code No. 72403050) when filling a tank in the model from a container used for transportation or storing.

■ RUNNING-IN

- Use a fuel with increased oil content and set the needle a little on the rich side. Too rich a needle setting may cause misfiring or erratic running due to fouling of the plug.
- Use a 25:1 fuel/oil mixture if the particular brand of oil states 50:1 mix. Use a 20:1 fuel/oil mixture if the particular brand of oil states 25:1 mix. Set only the high speed needle 200 below maximum rpm. The low speed needle need not be richened.
- No need to carry out running-in on a bench nor with the model fixed. Just fly the model with the above mentioned fuel and needle setting.
- A total of 10 flights (2 liters fuel) are required. Avoid prolonged full throttle running at initial stage, and gradually extend the full throttle running time.

WARNING:

When ground running the engine, avoid dusty or sandy locations. If dust or grit is drawn into the engine, this can have a ruinous effect, drastically shortening engine life in a matter of minutes.

■ STARTING

- The GT15 cannot be started by flipping a propeller. Be use to use an electric starter to start the engine.
 - The GT15 is not equipped with a choke valve. Draw the fuel to the carburetor by an electric starter.
1. Open the needle-valve 2.5 to 3 turns from the fully closed position. (Mixture control valve is pre-set at nearly best position when the engine leaves the factory. Therefore, do not adjust the mixture control valve at this point.)
 2. Turn the transmitter switch ON.
 3. Turn the receiver switch ON.
 4. Turn the igniter switch OFF.
 5. Set the throttle at half opened position.
 6. Draw the fuel to the carburetor by turning the engine for 7 to 8 seconds with an electric starter.
 7. Set the throttle at 1/4 open (6~7 clicks) from the fully closed position.
 8. Turn the igniter switch ON.
 9. Tell the helper and onlookers that you will start the engine now and have the helper hold the model securely.
 10. Apply an electric starter to start the engine.

■ CARBURETOR ADJUSTMENT

1. Before attempting to operate your engine

Although the carburetor's appearance and construction resemble conventional glow engine's carburetor, how to adjust is completely different from that for glow engine's carburetor. Please study the following instructions so as to familiarize yourself with the controls and other features of the engine.

- It is expected the engine runs a little unstably (uneven RPM and light breathing) until the inside parts of the carburetor get used to the fuel (around when the running-in is completed) but the engine won't quit. Run the engine as it is. Also, for about 10 seconds after the first starting of the day, it is expected the engine runs unstably but the engine won't quit. Run the engine as it is.

2. Key points for adjustments

- 1) Mixture control valve is pre-set at nearly best position when the engine leaves the factory. Therefore, it is not necessary to adjust the mixture control valve until running-in is completed. Adjust the needle-valve only.
- 2) **With a conventional glow engine, the needle-valve is gradually closed from the rich mixture. On the contrary, with the GT15, the needle-valve is opened from the lean mixture. Please fully note this difference.**

3. Adjustments

1) Needle-valve adjustment

1. Open the throttle fully gradually when the engine is started.
2. Close the needle-valve and the engine RPM increase. (Close the needle-valve at a pace of 30~45 degrees/second smoothly.)

3. When the needle-valve is closed further, engine RPM stop increasing and then RPM start decreasing. Close the needle-valve 60 to 90 degrees further from the point where RPM start decreasing.
4. Then, open the needle-valve rather slowly (at a pace of 15 degrees/second) and the engine RPM increase.
5. Open the needle-valve 90 degrees further from the point where maximum RPM are obtained. This is the nearly best needle-valve position.

Fly the model with this needle-valve position until running-in is completed (10 full tank or 2 liters flights). Please observe the general precautions during running-in such as to avoid prolonged full throttle running and increase load gradually.

2) Adjustment after running-in

1. Open the mixture control valve 60 degrees from the original position (factory setting).
2. Start the engine.
3. Open the throttle fully 5 to 6 seconds to warm the engine up.
4. Close the throttle fully.
5. Set the idling RPM at round 3,000 with the throttle trim on the transmitter.
6. Stop the engine.
7. Close the mixture control valve 15 degrees.
8. Start the engine and write down the idling RPM.
9. Repeat 6 to 8. 9. The position where 90 degrees opened position from maximum idling RMP is obtained is the optimum mixture control valve position. Warning! Never adjust the mixture control valve while running the engine.
10. Readjust the needle-valve according to 3. (1) described above.
11. Now the adjustment on the ground is completed.

Hereafter adjust the needle-valve and/or mixture control valve if required according to the flight conditions. Please note with this carburetor, needle-valve adjustment does not effect the mixture control valve adjustment but the mixture control valve adjustment effects the needle-valve adjustment.

Therefore, it is required to adjust also the needle-valve when the mixture control valve is adjusted.

3) Initial mixture control valve position

While the mixture control valve is set at nearly best position when the engine leaves the factory, it is possible you lost the initial position in repeating the mixture control valve adjustment.

How to reset the initial mixture control valve position is as follows. Please note this work is very sensitive. Carry out the work very carefully.

1. Open the mixture control valve one turn (360 degrees).
2. Repeat opening the throttle fully and closing the throttle fully a few times to make sure there is no resistance during throttle movement.
3. Close the mixture control valve 30 degrees.
4. Repeat 2. and 3. until resistance is felt when opening the throttle from fully closed position.
5. Open the mixture control valve approx. 90 degrees from this point. This is the initial mixture control valve position.

Note

Generally, a gasoline engine is sensitive to a lean mixture compared with a glow engine, and will stop without warning hesitation and stops with overheating. It is recommended that the engine be run with a slightly richer mixture.

■ FLIGHT & MAINTENANCE

■ Checking prior to flight

- When the engine is started, make sure the radio control system works normally (distance test).
- Engine does not run erratic with full throttle.
- Idling is stable.
- Responds positively to the throttle operation.
- Warm-up is finished.

Warm-up is required as with full size aircraft and car engines. Take off the model after warming the engine for approx. 10 seconds with full throttle.

■ Precautions in flight

- A slight engine rpm increase and decrease delay is normal. Abrupt throttle operation will the cause engine to quit. Move throttle smoothly.
- Cooling is more vitally important to a gasoline engine than to a glow engine. If overheating symptoms (loss of power at full throttle or exhaust note at mid speed changes from cloudy one to clear one) are observed during flight, immediately stop flying and carry out the following countermeasures.
 - 1) Enlarge the air intake cutout on the cowling.
 - 2) Enlarge the air outlet cutout on the cowling. (It is vitally important.)
 - 3) Partly cover the air intake cutout on the cowling where air does not hit direct the engine.
 - 4) Install an air guiding plate on the fuselage and cowling so that cooling air may be guided to the cylinder portion of the engine and muffler.
- When the interval between the flights is short and the engine is still hot, it may be possible overheating symptoms are observed by circulating the head from the former flight through the engine even if the overheating symptoms were not observed during the former flight. In this case, leave it until the engine is fully cooled down (in hot weather, it may take more than one hour.) or run the engine for 4 to 5 minutes at idle.

■ Maintenance after the day's flights

Please pay attention to the matter described below to ensure that your engine serves you well in regard to performance, reliability and long life.

- Check the tightening of each screw, especially engine installation screws and silencer installation screws each time. Also, for the first several flights, tighten the screws after each flight.
- As previously mentioned, it is vitally important to avoid operating the engine in conditions where dust, distributed by the propeller, may be deposited on the engine and enter its working parts.
- Remember to keep your fuel container closed to prevent foreign matter from contaminating the fuel.
- Install a fuel filter to prevent foreign matter in the fuel container from entering the fuel tank. O.S. Super Filter (L) is available as an optional extra.
- Install an in-line fuel filter between the tank and carburetor to prevent foreign matter in the tank from entering the carburetor.
- Clean these filters periodically.
- If these precautions are neglected, restrictions of fuel flow may cause the engine to cut out, or the fuel/air mixture to become too lean causing the engine to overheat.
- With a gasoline engine rust hardly occurs. Check the exterior to make sure there is nothing wrong and wipe off any oil res.
- Fill the carburetor with fuel at the conclusion of a day's flying. (Pay careful attention to fire and ignition source when carrying and storing the model.) If the engine is stored without filling the carburetor, with fuel the inside parts will dry out and not work properly at the next running. If the engine quits out of fuel, refill the carburetor with fuel.
- When the engine is not to be used for a long period (more than a year), remove the engine from the model, clean the outside then remove the carburetor, and plug all tubing. Clean inside the engine by rotating the crankshaft with the engine immersed in container filled with gasoline.
- Also use gasoline to clean the outside of the carburetor. Clean the outside only because the inside parts are sensitive to foreign substances.
- After cleaning the engine, dry it well then inject a small quantity of oil used to mix fuel and rotate the crankshaft several times to distribute the oil well inside the engine. Finally reassemble the engine and store it in a dry place after inserting it in a heavy vinyl bag.

ENGINE EXPLODED VIEW

* Type of screw

C...Cap Screw N...Round Head Screw

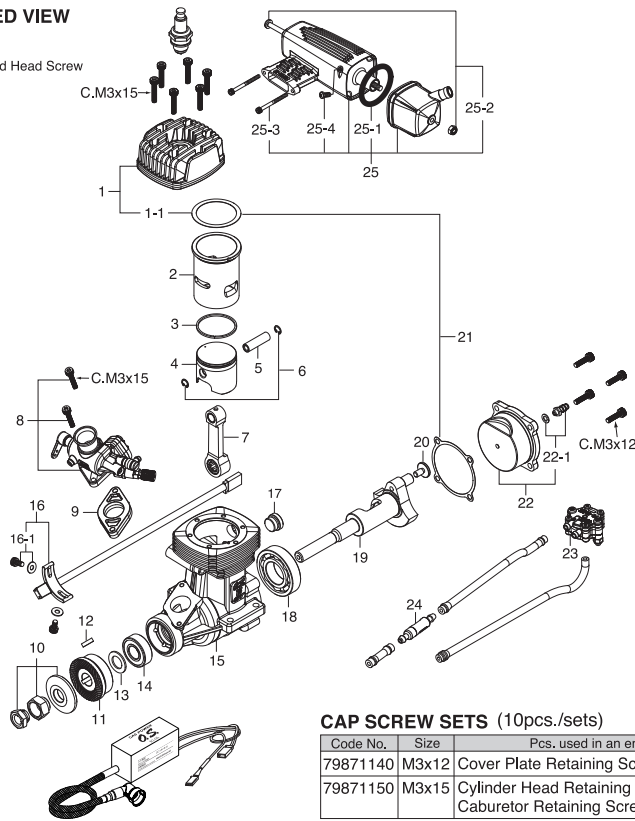

CAP SCREW SETS (10pcs./sets)

Code No.	Size	Pcs. used in an engine
79871140	M3x12	Cover Plate Retaining Screw (4pcs.)
79871150	M3x15	Cylinder Head Retaining Screw (6pcs.) Carburetor Retaining Screw (2pcs.)

No.	Code No.	Description
1	28164000	Cylinder Head
1-1	29061406	Head Gasket
2	29503100	Cylinder Liner
3	28153400	Piston Ring
4	28163200	Piston
5	26606008	Piston Pin
6	28117010	Piston Pin Retainer
7	28155000	Connecting Rod
8	28181010	Carburetor Complete (Type 61H)
9	28169460	Thermo Insulator
10	45910100	Lock Nut Set
11	28168000	Drive Hub
12	29008219	Woodruff Key
13	46120000	Thrust Washer
14	26731002	Ball Bearing (F)
15	28161000	Crankcase
16	74002320	Rotation Sensor
16-1	74002321	Rotation Sensor Retaining Screw Set (2pcs.)
17	28151300	Crankcase Plug
18	29030001	Ball Bearing (R)
19	28162000	Crankshaft
20	28152100	Crank Pin Stop Screw
21	29514000	Gasket Set
22	28167010	Cover Plate
22-1	4A281950	Nipple No.20
23	72508100	Pump Unit PD-08
24	78300000	Gasoline Fuel Filter S
25	27425011	E-4040 Silencer
25-1	29122540	"O" Ring
25-2	27425300	Assembly Screw
25-3	26625210	Silencer Retaining Screw (C.M4x40 2pcs.)
25-4	23081706	Carburetor Retaining Screw (N.+M3.5x5 2pcs.)
	71669010	Spark Plug CM-6 (Rcexl)
	74002710	Ignition Module (IG-06)

CARBURETOR EXPLODED VIEW & PARTS LIST

* Type of screw

N...Round Head Screw S...Set Screw

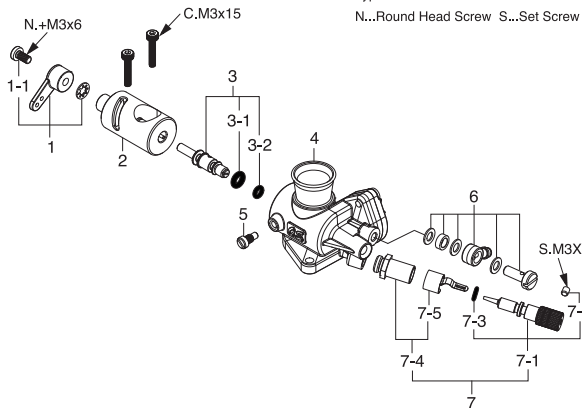

No.	Code No.	Description
1	27881400	Throttle Lever Assembly
1-1	22081313	Throttle Lever Retaining Screw
2	28181210	Carburetor Rotor
3	28181600	Mixture Control Valve Assembly
3-1	28181920	"O" Ring (L) (2pcs.)
3-2	28181910	"O" Ring (S) (2pcs.)
4	28181110	Carburetor Body
5	45581820	Rotor Guide Screw
6	45571110	Universal Nipple L3.5
7	28181100	Needle Valve Assembly
7-1	28181101	Needle Assembly
7-2	26381501	Set Screw
7-3	28181910	"O" Ring (2pcs.)
7-4	27381940	Needle-valve Holder Assembly
7-5	26711305	Ratchet Spring No.4

THREE VIEW DRAWING Dimensions (mm)

SPECIFICATIONS

Displacement	14.95 cc / 0.912 cu.in.
Bore	27.7 mm / 1.091 in.
Stroke	24.8 mm / 0.976 in.
Output	2.4 ps / 2.37 hp / 15,000 r.p.m.
Practical R.P.M.	2,000-15,000 r.p.m.
Weight	631 g / 22.26 oz. (Engine) 169 g / 5.97 oz. (Silencer) 95 g / 3.35 oz. (Ignition module)

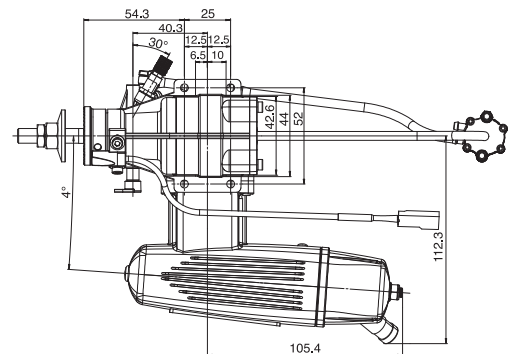

O.S. GENUINE PARTS & ACCESSORIES

- SPARK PLUG CM-6 (NGK) (71669000)
- E-4051 Silencer Assembly (27426010)
- PROPELLER LOCKNUT SET FOR SPINNER
 - 5/16"-M4 (45910200)
 - 5/16"-M5 (45910300)
- NON-BUBBLE WEIGHT (S) (71531010)
- LOCK WASHER (10sets) M4 (55500003)
- FLUORORUBBER TUBE
 - ID. 2mm x OD. 4mm Length 500mm (28382100)
 - ID. 3mm x OD. 5mm Length 500mm (28382200)
- SUPER FILTER (S) (72403051)
- SUPER FILTER (L) (72403050)
- BLIND NUT (10pcs.) M4 (79870040)

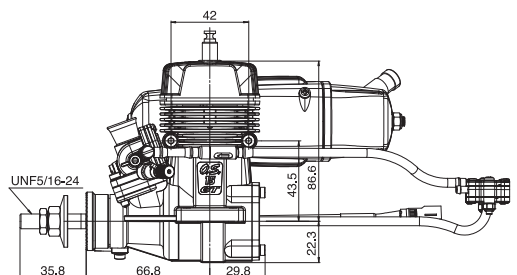
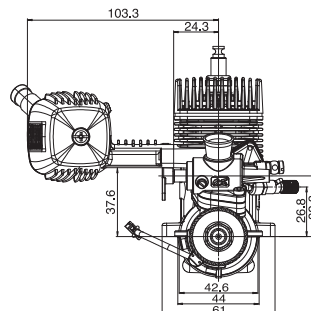

O.S. ENGINES MFG.CO.,LTD.
http://www.os-engines.co.jp

6-15 3-Chome Imagawa Higashiumiyoshi-ku
Osaka 546-0003, Japan TEL. (06) 6702-0225
FAX. (06) 6704-2722