

# T4PM PLUS



## INSTRUCTION MANUAL

## INTRODUCTION

Thank you for purchasing a Futaba T-FHSS SR 2.4GHz\* 4PM digital proportional R/C system. This system is extremely versatile and may be used by beginners and pros alike. In order for you to make the best use of your system and to drive safely, please read this manual carefully. If you have any difficulties while using your system, please consult the manual, our online Frequently Asked Questions (on the web pages referenced below), your hobby dealer.

Due to unforeseen changes in production procedures, the information contained in this manual is subject to change without notice.

**<http://www.futabausa.com>**

(<http://www.rc.futaba.co.jp/english>)

### **Application, Export, and Modification**

1. This product is only designed for use with radio control models. Use of the product described in this instruction manual is limited to radio control models.
2. Exportation precautions:
  - (a) When this product is exported, it cannot be used where prohibited by the laws governing radio waves of the destination country.
  - (b) Use of this product with other than models may be restricted by Export and Trade Control Regulations.
3. Modification, adjustment, and replacement of parts: Futaba is not responsible for unauthorized modification, adjustment, or replacement of parts on this product.

### **OUTSIDE NORTH AMERICA**

Please contact the Futaba importer in your region of the world to assist you with any questions, problems or service needs. Please recognize that all information in this manual, and all support availability, is based upon the systems sold in North America only. Products purchased elsewhere may vary. Always contact your region's support center for assistance.

## **Compliance Information Statement (for U.S.A.)**

This device complies with part 15 of the FCC Rules. Operation is subject to the following three conditions:

(1) This device may not cause harmful interference, and (2) This device must accept any interference received, including interference that may cause undesired operation.

(3) RF Radiation Exposure Statement (For T4PM PLUS)

This equipment complies with FCC radiation exposure limits set forth for an uncontrolled environment. This transmitter must not be co-located or operating in conjunction with any other antenna or transmitter.

RF Radiation Exposure Statement (For R304SB / R304SB-E / R334SBS / R334SBS-E)

This equipment complies with FCC radiation exposure limits set forth for an uncontrolled environment. This equipment should be installed and operated with minimum distance 20cm between the radio and your body.

The responsible party for the compliance of this device is:

Futaba Service Center

2681 Wall Triana Hwy Huntsville, AL 35824, U.S.A.

TEL 1-256-461-9399 or E-mail: [contactus@futaba.com](mailto:contactus@futaba.com)

## **CAUTION:**

To assure continued FCC compliance:

Any changes or modifications not expressly approved by the grantee of this device could void the user's authority to operate the equipment.

## **Compliance Information Statement (for Canada)**

This device complies with Industry Canada license-exempt RSS standard(s). Operation is subject to the following two conditions: (1) this device may not cause interference, and (2) this device must accept any interference, including interference that may cause undesired operation of the device. This equipment complies with IC radiation exposure limits set forth for an uncontrolled environment. This transmitter must not be co-located or operating in conjunction with any other antenna or transmitter.

French: Cet appareil radio est conforme au CNR-247 d'Industrie Canada. L'utilisation de ce dispositif est autorisée seulement aux deux conditions suivantes : (1) il ne doit pas produire de brouillage, et (2) l'utilisateur du dispositif doit être prêt à accepter tout brouillage radioélectrique reçu, même si ce brouillage est susceptible de compromettre le fonctionnement du dispositif. Cet équipement est conforme aux limites d'exposition aux rayonnements IC établies pour un environnement non contrôlé.

Cet équipement est conforme aux limites d'exposition aux rayonnements IC établies pour un environnement non contrôlé. Cet émetteur ne doit pas être co-situé ou fonctionner conjointement avec une autre antenne ou émetteur.

## **Declaration of Conformity (for EU)**

Hereby, Futaba Corporation declares that the radio equipment type is in compliance with Directive 2014/53/EU.

The full text of the EU declaration of conformity is available at the following internet address:

<http://www.rc.futaba.co.jp/english/dl/declarations.html>

# Table Of Contents



## **For Your Safety As Well As That Of Others ..... 8**

<b>Explanation Of Symbols .....</b>	<b>8</b>
<b>2.4GHz System Precautions .....</b>	<b>8</b>
<b>Receiver System Precautions .....</b>	<b>8</b>
<b>Operation Precautions.....</b>	<b>9</b>
<b>NiMH / NiCd / LiFe Battery Handling Precautions .....</b>	<b>10</b>
<b>Storage And Disposal Precautions .....</b>	<b>10</b>
<b>Other Precautions .....</b>	<b>11</b>

## **Before Using ..... 12**

<b>Features .....</b>	<b>12</b>
<b>Set Contents .....</b>	<b>14</b>
<b>Transmitter T4PM PLUS.....</b>	<b>15</b>
Nomenclature.....	15
Battery Replacement Method (4 AA Size Batteries) .....	16
Low Battery Alarm.....	16
When Using The Optional Battery.....	17
Power Switch & Key Operation.....	19
Display When Power Switch Is Turned On .....	19
Power Off Reminder Alarm & Auto Power Off .....	20
Steering Wheel And Throttle Trigger Operation.....	20
Digital Trim Operation.....	21
Mechanical ATL Adjustment .....	21
Wheel & Trigger Tension Adjustment.....	22
Trigger Slide Adjustment.....	22
<b>About Transmitter Antenna And Receiver .....</b>	<b>23</b>
About The Transmitter Antenna.....	23
Receiver Terminology .....	23
Receiver Installation .....	24

## **Installation ..... 25**

<b>Receiver And Servo Connections .....</b>	<b>25</b>
Installation When An Electronic Speed Control Is Used	
Installation For Gas Powered Models	
Connection Example Of S. BUS Using A Telemetry Sensor	
<b>Installation Safety Precautions.....</b>	<b>26</b>

## **Initial Set-Up ..... 29**

### **Preparations (Transmitter) ..... 29**

Receiver System Check (RECEIVER).....	29
Receiver System Change & How To Link .....	30
How To set The SR Mode Channel.....	35
Throttle Mode Check.....	36
Trims Initial Set-Up .....	36

## **Function Map ..... 38**

### **Operation Of Screen ..... 38**

Calling The Menu Screen .....	38
Selecting Items On The Menu Screen.....	39
Value Of Each Function And Changing The Set Value .....	39
Basic Menu Japanese Katakana Character Display .....	40

### **Function List ..... 41**

## **Functions ..... 42**

### **System Functions "SYSTEM" ..... 42**

Adjusting the liquid crystal contrast	
Setting the liquid crystal backlighting mode	
Setting liquid crystal backlighting time	
Setting liquid crystal backlighting brightness	
Setting the battery type	
Adjusting the buzzer tone	
Changing the power off reminder alarm setting	
Changing the menu character display	
Changing the HOME screen display mode	

### **Servo Reverse "REVERSE" ..... 46**

Servo operation reversing	
---------------------------	--

### **Subtrim "SUBTRIM" ..... 47**

Servo center position fine adjustment	
---------------------------------------	--

### **End Point Adjuster "END POINT" ..... 48**

End point adjustment	
----------------------	--

### **Exponential Adjustment "EXP" ..... 51**

Steering operation curve / Throttle curve adjustment.	
---	--

### **Servo Speed "SPEED" ..... 54**

Steering / Throttle servo delay adjustment	
--	--

### **Throttle Acceleration "TH ACCEL" ..... 57**

Function which adjusts the movement characteristic from the throttle neutral position	
---	--

### **A.B.S. Function "TH A.B.S" ..... 59**

Pulse brake	
-------------	--

### **Throttle Mode "TH MODE" ..... 63**

Throttle Servo Neutral Position "SXNT" .....	63
Throttle servo forward and brake operation proportion setting	
Idle-Up "IDLUP" .....	64
Idle up at engine start	

Neutral Brake "NTBRK" .....	65
Neutral brake function	
Throttle Off (Engine Cut) "THOFF" .....	66
Engine cut off by switch	
<b>Traction Function "TRACTION" .....</b>	<b>67</b>
Function to make traction progress by intermittently moving the throttle	
<b>Start Function "START" .....</b>	<b>70</b>
Throttle preset at start function	
<b>Steering Dual Rate / Throttle ATL "D/R ATL" .....</b>	<b>72</b>
Steering D/R, Throttle ATL Rate	
<b>Channel 3/4 "CH3/CH4" .....</b>	<b>73</b>
Channel 3/4 Position	
<b>Model Selection "MDL SELE" .....</b>	<b>74</b>
Model memory call	
<b>Model Name "MDL NAME" .....</b>	<b>75</b>
Model memory name & User name, set/modify	
<b>Model Copy "MDL COPY" .....</b>	<b>76</b>
Model memory copy.	
<b>Model Reset "MDL RES" .....</b>	<b>79</b>
Model memory reset	
<b>Data Transfer "MDL TRANS" .....</b>	<b>80</b>
The T4PM PLUS model memory data to another T4PM PLUS	
<b>Model Delete (Saved on SD card) "MDL DELE" .....</b>	<b>82</b>
The T4PM PLUS model memory data to another T4PM PLUS	
<b>Fail Safe Function "FAIL SAFE" .....</b>	<b>83</b>
Fail safe, battery fail safe function	
<b>S.BUS Link Function "S.BUS SX" .....</b>	<b>85</b>
Special function, Futaba S.BUS / S.BUS2 servo parameter setup	
<b>ESC Link Function "MC LINK" .....</b>	<b>91</b>
Special function, Futaba ESC (MC940CR, MC960CR, MC950CR, MC851C, MC602C, MC402CR, etc.)	
<b>Gyro Link Function "GYRO LINK" .....</b>	<b>100</b>
Special function, Futaba gyeo parameter setup (GYD550)	
<b>Select Trim Dial Function "TRIM DIAL" .....</b>	<b>104</b>
Selection of functions operated by digital trim and dial	
<b>Select Switch Function "SWITCH" .....</b>	<b>106</b>
Selection of functions operated by switch	
<b>Steering Mixing "STR MIX" .....</b>	<b>108</b>
Twin servo steering system	
<b>Brake Mixing "BRAKE MIX" .....</b>	<b>110</b>
Front and rear independent brake control for 1/5 GP car, etc.	
<b>Gyro Mixing "GYRO MIX" .....</b>	<b>112</b>
Use to set the Futaba car rate gyro	
<b>4WS Mixing "4WS" .....</b>	<b>114</b>
Special mixing used with Crawler and other 4WS type vehicles	

<b>Dual ESC Mixing "DUAL ESC"</b> .....	<b>116</b>
Special mixing used with Crawler and other 4WD type vehicles	
<b>CPS Mixing "CPS MIX"</b> .....	<b>118</b>
Controls the Futaba CPS-1 channel power switch	
<b>Tank Mixing "TANK MIX"</b> .....	<b>120</b>
This function is intended for vehicles such as tanks	
<b>Programmable Mixing "PROG MIX"</b> .....	<b>122</b>
Programmable mixing between arbitrary channels	
<b>Timer Function "TIMER"</b> .....	<b>124</b>
Up, Fuel down, or lap timer	
<b>Lap List "LAP LIST"</b> .....	<b>130</b>
Lap timer data check	
<b>Telemetry "TELEMETRY"</b> .....	<b>131</b>
Connection diagram .....	132
Telemetry Function ON/OFF .....	132
Telemetry Sensor Setting .....	134
Telemetry information display settings .....	137
Log Setting, Start/ Stop .....	138
Log Data List .....	140
Resets the sensor slot number "SENS-RST" .....	141
<b>Roll Out Chart "ROLL OUT"</b> .....	<b>142</b>
<b>Gear Ratio Chart "GEAR RAT"</b> .....	<b>143</b>
<b>Adjuster "ADJUSTER"</b> .....	<b>144</b>
Steering wheel and throttle trigger correction	
<b>Information "INFO"</b> .....	<b>146</b>
<b>Software Update</b> .....	<b>147</b>
Update the T4PM PLUS	

---

## **Reference .....** **148**

<b>Ratings</b> .....	<b>148</b>
<b>Warning Displays</b> .....	<b>149</b>
<b>Warranty &amp; Repair Service (In U.S.A)</b> .....	<b>151</b>

Use this product in a safe manner. Please observe the following safety precautions at all times.

## Explanation Of Symbols

For safety's sake, pay special attention whenever you see the marks shown here.

Symbols	Explanation
<b>Danger</b>	Indicates a procedure which could lead to a dangerous situation and may cause death or serious injury if ignored and not performed properly.
<b>Warning</b>	Indicates procedures which may lead to dangerous situations and could cause death or serious injury as well as superficial injury and physical damage.
<b>Caution</b>	Indicates procedures that may not cause serious injury, but could lead to physical damage.

Symbols: : Prohibited      : Mandatory

## 2.4GHz System Precautions

### **Warning**

- Special attention should be paid before turning on the system while other cars are running or other airplanes are flying because the 2.4GHz RC system could potentially affect them.
- Be sure to set the Fail-safe function.

## Receiver Mode Precautions

### **Caution**

- Be sure to use the T4PM PLUS receiver setting and the servo to be used under predetermined conditions.

Under other conditions, the set will not operate, or the specified performance will not be displayed even if it operates. In addition, it may cause servo trouble. Futaba will not be responsible for problems caused by the use of other than genuine Futaba parts. Use the parts specified in the instruction manual and catalog.

System	Response / SR mode	Usable servos
T-FHSS SR	<b>SR mode channel: ON</b>	- SR mode of Futaba SR compatible servo.
	<b>SR mode channel: OFF</b>	- Normal mode of Futaba SR compatible servo. - Futaba digital servo.
T-FHSS	<b>HI-SPEED mode</b>	- Normal mode of Futaba SR compatible servo. - Futaba digital servo.
	<b>NORMAL mode</b>	Futaba all servo. (Normal mode of Futaba SR compatible servo.)
S-FHSS	<b>HI-SPEED mode</b>	- Normal mode of Futaba SR compatible servo. - Futaba digital servo.
	<b>NORMAL mode</b>	- Futaba all servo. (Normal mode of Futaba SR compatible servo.)

\*Refer to country distributor WEB for detailed the "S. BUS servo menu" and the "SR mode setting" explanation.

Receiver battery: Matched to the ratings of the receiver and connected servo (dry cell battery cannot be used).

In addition, the FSU Fail-safe Unit cannot be used because the system is different. Use the fail-safe function of the transmitter. ([Refer to page 83.](#))



## Operation Precautions

### **Warning**

- ⊘ **Do not operate outdoors on rainy days, run through puddles of water or use when visibility is limited.**

Should any type of moisture (water or snow) enter any component of the system, erratic operation and loss of control may occur.

- ⊘ **Do not operate in the following places.**

- Near other sites where other radio control activity may occur.
- Near people or roads.
- On any pond when passenger boats are present.
- Near high tension power lines or communication broadcasting antennas.

Interference could cause loss of control. Improper installation of your Radio Control System in your model could result in serious injury.

- ⊘ **Do not operate this R/C system when you are tired, not feeling well or under the influence of alcohol or drugs.**

Your judgment is impaired and could result in a dangerous situation that may cause serious injury to yourself as well as others.

- ⊘ **Do not touch the engine, motor, speed control or any part of the model that will generate heat while the model is operating or immediately after its use.**

These parts may be very hot and can cause serious burns.

- ❗ **Always perform an operating range check prior to use.**

Problems with the radio control system as well as improper installation in a model could cause loss of control.

(Simple range test method)

Have a friend hold the model, or clamp it down or place it where the wheels or prop cannot come in contact with any object. Walk away and check to see if the servos follow the movement of the controls on the transmitter. Should you notice any abnormal operation, do not operate the model. Also check to be sure the model memory matches the model in use.

- ❗ **Turning on the power switches.**

**Always check the throttle trigger on the transmitter to be sure it is at the neutral position.**

1. Turn on the transmitter power switch.
2. Turn on the receiver or speed control power switch.

**Turning off the power switches**

**Always be sure the engine is not running or the motor is stopped.**

1. Turn off the receiver or speed control power switch.
2. Then turn off the transmitter power switch.

If the power switches are turned off in the opposite order, the model may unexpectedly run out of control and cause a very dangerous situation.

- ❗ **When making adjustments to the model, do so with the engine not running or the motor disconnected.**

You may unexpectedly lose control and create a dangerous situation.

- ❗ **Before running (cruising), check the fail-safe function.**

Check Method;

Before starting the engine, check the fail-safe function as follows:

- 1) Turn on the transmitter and receiver power switches.
- 2) Wait at least one minute, then turn off the transmitter power switch. (The transmitter automatically transfers the fail-safe data to the receiver every minute.)
- 3) Check if the fail-safe function moves the servos to the preset position when reception fails.

The fail-safe function is a safety feature that minimizes set damage by moving the servos to a preset position when reception fails. However, if set to a dangerous position, it has the opposite effect. When the reverse function was used to change the operating direction of a servo, the fail-safe function must be reset.

Setting example: Throttle idle or brake position



## NiMH / NiCd / LiFe Battery Handling Precautions

(Only when NiMH / NiCd / LiFe batteries are used)

### **Warning**

**⊘ Never plug the charger into an outlet of other than the indicated voltage.**

Plugging the charger into the wrong outlet could result in an explosion or fire.

**⊘ Never insert or remove the charger while your hands are wet.**

You may get an electric shock.

**⊘ Do not use the T4PM PLUS transmitter's battery as the receiver's battery.**

Since the transmitter's battery has an overload protection circuit, the output power will be shut down when the high current load is applied. This may result in runaway or fatal crash.

**⊘ Always check to be sure your batteries have been charged prior to operating the model.**

Should the battery go dead while the model is operating, loss of control will occur and create a very dangerous situation.

**❗ To recharge the transmitter battery, use the special charger made for this purpose.**

Overcharging could cause the battery to overheat, leak or explode. This may lead to fire, burns, loss of sight and many other types of injuries.

### **Caution**

**⊘ Do not use commercial AA size NiCd and NiMH batteries.**

Quick charging may cause the battery contacts to overheat and damage the battery holder.

**⊘ Do not short circuit the battery terminals.**

A short circuit across the battery terminals may cause abnormal heating, fire and burns.

**⊘ Do not drop the battery or expose it to strong shocks or vibrations.**

The battery may short circuit and overheat; electrolyte may leak out and cause burns or chemical damage.

**❗ When the model is not being used, always remove or disconnect the battery.**

Leaving the battery connected could create a dangerous situation if someone accidentally turns on the receiver power switch. Loss of control could occur.

**❗ Always keep the charger disconnected from the outlet while it is not in use.**

## Storage And Disposal Precautions

### **Warning**

**⊘ Do not leave the radio system or models within the reach of small children.**

A small child may accidentally operate the system. This could cause a dangerous situation and injuries. NiCd batteries can be very dangerous when mishandled and cause chemical damage.

**⊘ Do not throw NiMH / NiCd / LiFe batteries into a fire. Do not expose batteries to extreme heat. Also do not disassemble or modify a battery pack.**

Overheating and breakage will cause the electrolyte to leak from the cells and cause skin burns, loss of sight, and other injuries.



- ❗ **When the system will not be used for any length of time, store the system with NiMH / NiCd batteries in a discharged state. Be sure to recharge the batteries prior to the next time the system is used.**

If the batteries are repeatedly recharged in a slightly discharged state, the memory effect of the NiMH / NiCd battery may considerably reduce the capacity. A reduction in operating time will occur even when the batteries are charged for the recommended time. (After discharge to 1cell E.V.=1V)

- ❗ **When a LiFe battery pack will not be used for a long time, to prevent it from deteriorating we recommend that it be kept in about the half capacity state instead of fully charged. Also be careful that the battery does not enter the over-discharged state due to self-discharge.**

Periodically (about every 3 months) charge the battery.

## **Warning**

- ⊘ **Do not store your R/C system in the following places.**

- Where it is extremely hot or cold.
- Where the system will be exposed to direct sunlight.
- Where the humidity is high.
- Where vibration is prevalent.
- Where dust is prevalent.
- Where the system would be exposed to steam and condensation.

Storing your R/C system under adverse conditions could cause deformation and numerous problems with operation.

- ❗ **If the system will not be used for a long period of time, remove the batteries from the transmitter and model and store in a cool, dry place.**

If the batteries are left in the transmitter, electrolyte may leak and damage the transmitter. This applies to the model also. Remove the batteries from it also to prevent damage.

### <NiMH/NiCd Battery Electrolyte>

The electrolyte in NiCd / NiMH batteries is a strong alkali. Should you get even the smallest amount of the electrolyte in your eyes, DO NOT RUB. Wash immediately with water, and seek medical attention at once. The electrolyte can cause blindness. If electrolyte comes in contact with your skin or clothes, wash with water immediately.

### <NiMH / NiCd / LiFe Battery Recycling>

A used battery is a valuable resource. Insulate the battery terminals and dispose of the battery by taking it to a battery recycling center.

## Other Precautions

### **Caution**

- ⊘ **Do not expose plastic parts to fuel, motor spray, waste oil or exhaust.**

The fuel, motor spray, waste oil and exhaust will penetrate and damage the plastic.

- ❗ **Always use only genuine Futaba transmitters, receivers, servos, ESCs (electronic speed controls), NiMH/ NiCd / LiFe batteries and other optional accessories.**

Futaba will not be responsible for problems caused by the use of other than genuine Futaba parts. Use the parts specified in the instruction manual and catalog.



## Features

### **-T-FHSS SR (Super response) & telemetry T-FHSS**

In addition to the T-FHSS telemetry system, we added a T-FHSS SR (Super response) system that increased processing speed to further improve response. (SR system does not support telemetry function)

\*R304SB and R304SB-E are not compatible with SR system.

### **-MINIZ system**

Switch T4PM PLUS to the MINIZ system in the receiver setting menu. You can use the Futaba receivers RA-42 and MINI-Z EVO / FHSS for MINI-Z EVO of Kyosho Corporation.

(You need to purchase the dedicated receiver RA-42 and the FS-RM005 module for MINI-Z EVO / FHSS separately from Kyosho Co., Ltd.)

### **-Telemetry system**

The T4PM PLUS transmitter has adopted the newly developed bidirectional communication system "T-FHSS".

### **-2.4GHzSS (Spread Spectrum) radio communication system**

Frequency channel setting is unnecessary: Channel shifting takes place within the 2.4GHz band automatically. This system minimizes the interference from other 2.4GHz systems.

### **-Display switch**

Display switch allows function setup without transmitting.

### **-Model memory for 40 models**

Model names can use up to 10 letters, numbers, and symbols, so that logical names may be used. A model memory with different setups can be created by using the model copy function.

### **-4 axis Jog button.**

The (JOG) button can be operated in 4 directions: up, down, left, and right.

### **-ESC-Link function (MC-LINK)**

This dedicated function allows you set up the Link software so that your T4PM PLUS can control variable frequency and other data changes in Futaba speed controllers (ESCs): MC950CR, MC850C, MC851C, MC602C, MC402CR, etc.

### **-S.BUS servo**

This is a special function that allows setting of the parameters of our S.BUS servo whose settings are changed by using PC Link software. In addition to the conventional wired system, it can be set wirelessly in combination with the R334SBS or R334SBS-E.

### **-Steering mixing**

Smooth cornering is possible by independent left and right steering servo setting.

### **-Brake mixing for large cars (BRAKE)**

Brake mixing of the front and rear wheels of 1/5 gas power cars and other large cars can be adjusted independently.

### **-Gyro mixing (GYRO MIX)**

The sensitivity of Futaba car rate gyros can be adjusted from the T4PM PLUS.



### **-4WS mixing for crawlers and other 4WS type (4WS)**

This function can be used with crawlers and other 4WS type vehicles.

### **-Dual ESCs mixing for crawlers cars (DUAL ESC)**

ESCs at the front and rear are controlled independently.

### **-CPS-1 mixing (CPS MIX)**

LED lighting and flashing control using our CPS-1 channel power switch can be matched to steering and throttle operation by switch only.

### **-Anti-skid braking system (TH A.B.S)**

This function applies the brakes so that the tires of gas power cars, etc. do not lose their grip on the road even when braking at corners.

### **-Throttle acceleration (ACCEL)**

gas power cars have a time lag before the clutch and brakes become effective. The throttle acceleration function reduces this time lag.

### **-Throttle speed (SPEED)**

Sudden trigger operation on a slippery road surface will only cause the tires to spin and the model to not accelerate smoothly. By setting the throttle speed function, operation can be performed smoothly and easily. It also suppresses battery consumption.

### **-Steering speed (SPEED)**

When you sense that the steering servo is too fast, etc., the servo operating speed (direction that suppresses the maximum speed) can be adjusted.

### **-Racing timer (TIMER)**

The lap timer can record 100 lap times and total time. The timer can also be started automatically by trigger operation. The race time and audible alarm can be set.

Re-/fueling time are indicated by an audible alarm. An up timer is also provided.

### **-Function select switch (SWITCH)/ dial function (TRIM DIAL)**

This assigns functions to 2 switches and dials (digital trim, digital dial). The step amount and operating direction can also be adjusted. Trim positioning at each model call is unnecessary because all the dials are digital.

### **-Trigger position can be changed**

The position of the throttle trigger can be moved forward and backward.

### **-Tension adjustment function**

The tension of the steering wheel & throttle trigger springs can be adjusted from the outside.

### **-Mechanical ATL Adjustment**

Make this adjustment when you want to decrease the total travel of the brake (push) side of the throttle trigger.



## Set Contents

After opening the box, first check if the contents conform to the following. The contents depend on the set as shown below.

<b>Transmitter</b>	<b>T4PM PLUS</b>
<b>Receiver</b>	<b>R304SB / R304SB-E / R334SBS / R334SBS-E</b>
<b>Miscellaneous</b>	<b>Miscellaneous Dry battery holder</b> <small>*Installed in transmitter.</small> <b>Mini screwdriver</b> <small>* It is used for receiver.</small> <b>1.5mm hex wrench / 2.0mm hex wrench</b> <b>Instruction manual</b>

- If any of the set contents are missing, or you have any questions, please contact your dealer.

### **Caution**

- ⊘ The R304SB-E and R334SBS-E receivers are for electric. Please do not use for the gas powered models.
- ⓘ Always use only genuine Futaba transmitters, receivers, servos, ESCs (electronic speed controls), batteries and other optional accessories.

Futaba will not be responsible for problems caused by the use of other than Futaba genuine parts. Use the parts specified in the instruction manual and catalog.

- ⊘ The R304SB, R304SB-E receiver is not compatible with SR mode.

The following parts are available as 4PM PLUS options. Purchase them to match your application. For other optional parts, refer to our catalog.

### **Transmitter Battery**

When purchasing a transmitter battery use the following:

FT2F1100 (6.6V/1100mAh) / FT2F1700V2 (6.6V/1700mAh) / 2100BV2 (6.6V/2100mAh) LiFe battery  
Please do not use the transmitter batteries ( FT2F1100B / FT2F1700V2 / 2100BV2) as the receiver's battery.

Since the transmitter's battery has an overload protection circuit, the output power will be shut down when the high current load is applied. This may result in runaway or fatal crash.

### **10PX/7PXR/7PX/4PM Handle**

This handle is option part for carrying T4PM PLUS. Please read the installation instructions of the handle carefully for mounting method and precautions.

### **Telemetry Sensor**

Usable sensor options (As of August 2022)

Voltage Sensor (SBS-01V) / Temperature sensor (SBS-01T) /Temperature sensor (SBS-01TE) /RPM Sensor (SBS-01RM) /RPM Sensor (SBS-01RB) (Brushless type) /Current sensor (SBS-01C)

### **Other**

DSC cable for data transfer (For updating transmitter with CIU-3)

Inductive Charging System ICS LF-01 (Li-FePO4 battery inductive charger for T7PX / T4PV / T4PM)

Dry Battery Box for Transmitter 4P-SQ (It is a standard item attached to T4PM PLUS.)



# Transmitter T4PM PLUS

## Nomenclature

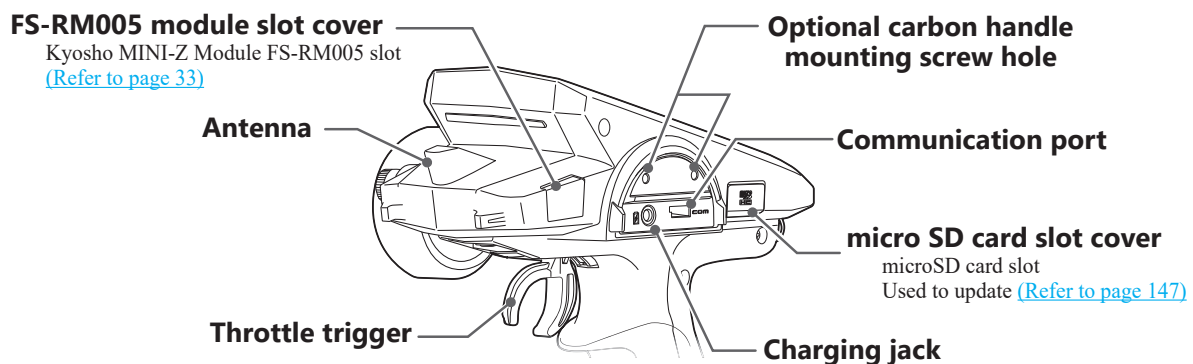
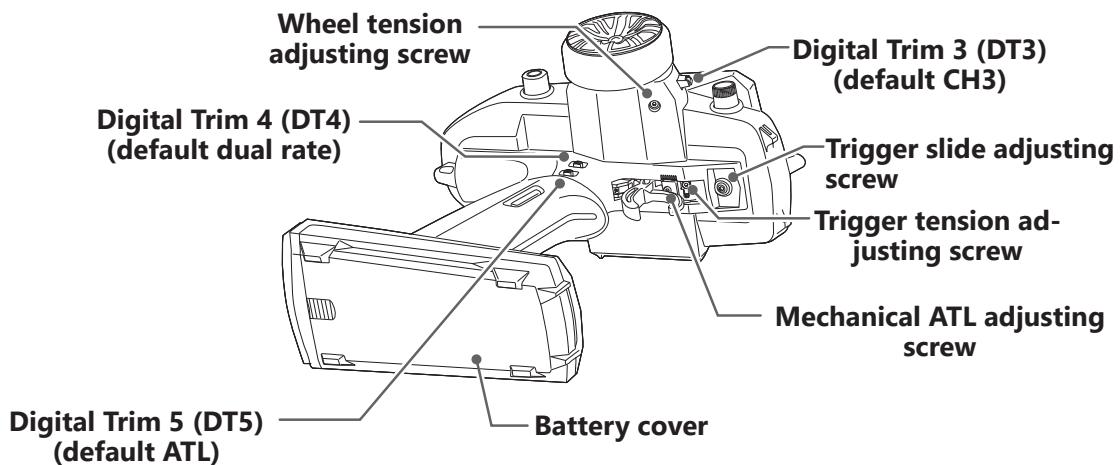
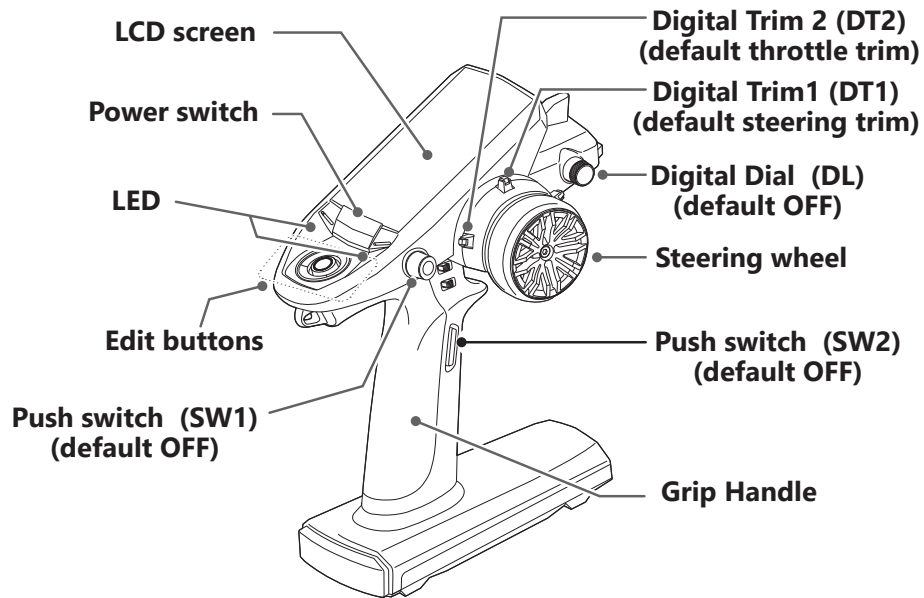

\*The switches, dial, and trimmers in the figure are shown in the initial setting position.



## Battery Replacement Method (4 AA Size Batteries)

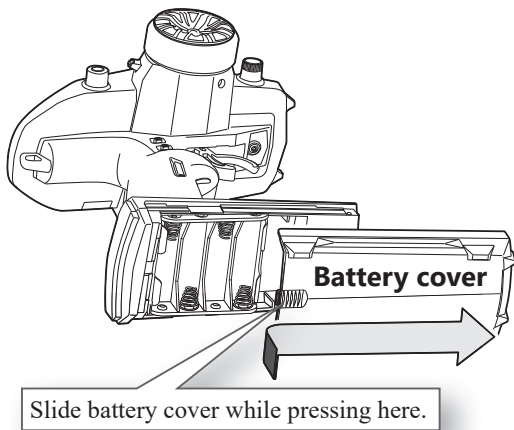

### ⚠ Caution

- ⊘ **Never try to recharge a dry cell battery.**  
The transmitter may be damaged or the battery electrolyte may leak or the battery may break.
- ⓘ **Insert the batteries in the correct polarity.**  
If the polarity is incorrect, the transmitter may be damaged.
- ⓘ **When the transmitter is not in use, remove the batteries.**  
If the battery electrolyte leaks, wipe off the case and contacts.
- ⊘ **Do not use commercial AA size NiCd and NiMH batteries.**  
Since voltage is lower than alkaline dry battery, usable time is shortened.  
Quick charging may cause the battery contacts to overheat and damage the battery holder.



### Battery Replacement Method

- 1** Remove the battery cover from the transmitter by sliding it in the direction of the arrow in the figure.
- 2** Remove the used batteries. Load the new AA size alkaline dry batteries. Pay very close attention to the polarity markings and reinsert accordingly.
- 3** Slide the battery cover back onto the case.

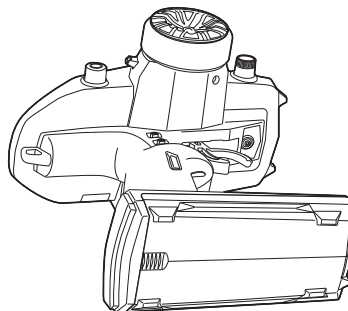
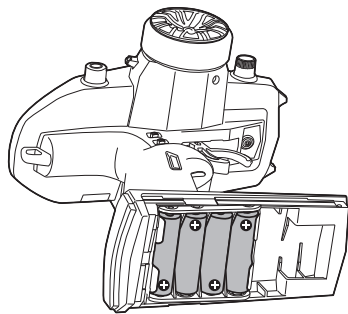
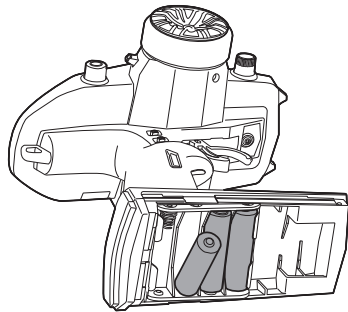

#### Check:

Turn the power switch on the transmitter to the ON position. Check the battery voltage display on the LCD screen. If the voltage is low, check the batteries for insufficient contact in the case or incorrect battery polarity.

#### Disposal of the Dry Cell Batteries:

The method to dispose of used dry cell batteries depends on the area in which you reside. Dispose of the batteries in accordance with the regulations for your area.

#### [Low Battery Alarm]

If the transmitter battery voltage drops below the usable range, an audible alarm will sound and "⚡" mark will be displayed on the LCD screen.

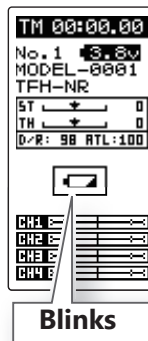

### ⚠ Warning

- ⓘ **When a low battery alarm is generated, cease operation immediately and retrieve the model. Always replace with a new dry battery before running next.**  
If the battery goes dead while in operation, you will lose control of the model.



## When Using The Optional Battery

When using an optional rechargeable battery, replace the battery as described below.

-Always use the optional FT2F1100B, FT2F1700BV2 or FT2F2100BV2 rechargeable battery.

-Be sure to attach the included battery spacer to the battery.

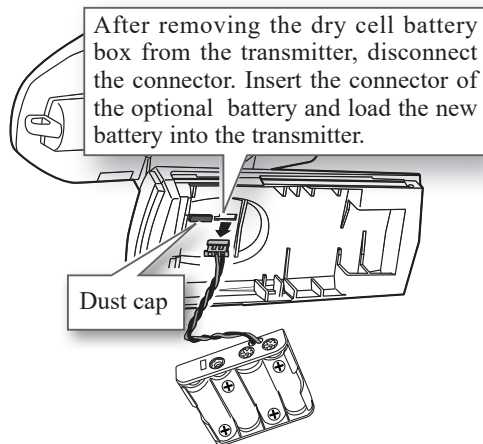

### Battery Replacement Method

- 1 Refer to the previous description and remove the transmitter battery cover. (See page 16)  
After removing the dry cell battery box from the transmitter, disconnect the connector.
- 2 Insert the connector of the new battery and load the new battery into the transmitter. Finish by installing the battery cover.

Connect the battery connector

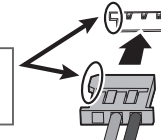

### ⚠ Caution

- ⊗ Please do not push the dust cap of the figure strongly.

If it is pushed into the case, it cannot remove.

- ⚠ When closing the battery cover, be careful that the battery cover does not pinch the battery lead wires.

Shorting of the battery lead wires may lead to fire and abnormal heating and cause burns or fire disaster.

- ⚠ Since the usable range of LiFe batteries is different, the power supply used must be set by system setting (page 42-44).

If used with wrong setting, the transmitter may shut down before warning of low battery alarm. There is a danger that a car (boat) runs away.

- ⚠ When a low battery alarm is generated, cease operation immediately and retrieve the model. Always charge before use.

If the battery goes dead while in operation, you will lose control of the model.

### ⚠ Caution

- ⊗ When installing the battery box for dry batteries, pay attention to the wiring orientation, referring to the figure below.

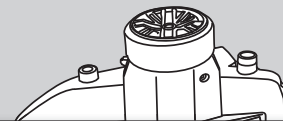

Carefully push the wiring of the battery box into the gap in the front side of the transmitter, and install it carefully so as not to damage the wiring.

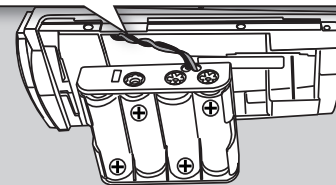

### Charging A LiFe Battery

(Example: When using the FT2F1100B / 1700BV2 / 2100BV2 with the special charger)

- 1 Plug the transmitter cord of the special charger into the charging jack on the rear of the transmitter.
- 2 Plug the charger into an AC outlet.
- 3 Check that the charging LED lights red.
- 4 When charging is completed, the charging LED lights green. Disconnect the charge plug and disconnect the AC plug of the charger.

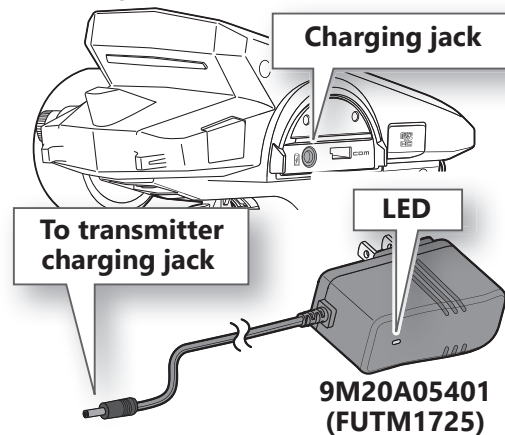

9M20A05401 (FUTM1725)



## With Balance Charger

(Example: When using the FT2F100B / 1700BV2 / 2100BV2 with an optional charger)

- 1 Remove the battery cover.
- 2 Disconnect the battery from the T4PM PLUS.
- 3 Balance charging cannot be done through the transmitter. You must remove the LiFe battery to do this charge.  
Follow the directions of the optional LiFe chargers in use.

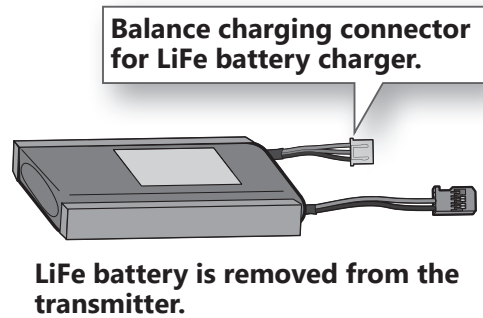

The charging time when charging the FT2F2100BV2 battery with the optional special charger is approximately 3 hours, the FT2F1700BV2 battery is 2.5 hours, the FT2F1700BV2 battery is 2 hours. When the LiFe battery will not be used for a long time, to prevent it from deteriorating we recommend that it be kept in about the half capacity state instead of fully charged. Also be careful that the battery does not enter the overdischarged state due to self discharge. Periodically (about every 3 months) charge the battery. In addition, always remove the battery from the model and store it in a dry, cool place (15°C~25°C).

### Warning

- ⊘ Make sure not to peel off the battery film, or make any scratch by a cutter knife or the sharp edges of metal components.
- ⊘ Make sure not to soak or get the battery wet with water or seawater.
- ⊘ Make sure not to use a deformed or swollen battery.  
There is a risk of explosion or fire, which is very dangerous.

## Caution on charger

### Warning

- ⊘ The charger 9M20A05401 (FUTM 1725) does not charge batteries other than FT2F1100B / FT-2F1700B V2 / FT2F2100B V2.  
Overcharging could cause the battery to overheat, leak or explode. This may lead to fire, burns, loss of sight and many other types of injuries.
- ⊘ Never plug it into an outlet having other than the indicated voltage.  
Plugging the charger into the wrong outlet could result in an explosion or fire.
- ⊘ Do not insert and remove the charger when your hands are wet.  
It may cause an electric shock.
- ⓘ Always use the special charger or a quick charger for digital proportional R/C sets to charge a digital proportional R/C set battery.  
Overcharging a NiMH battery can result in burns, fire, injuries, or loss of sight due to overheating, breakage, or electrolyte leakage.

### Caution

- ⊘ Do not plug the charger to the charging jack, if the battery is not connected to the transmitter.  
The transmitter may be damaged.
- ⓘ When the charger is not in use, disconnect it from the AC outlet.  
Do this to prevent accidents and to avoid overheating.

# Power Switch & Key Operation

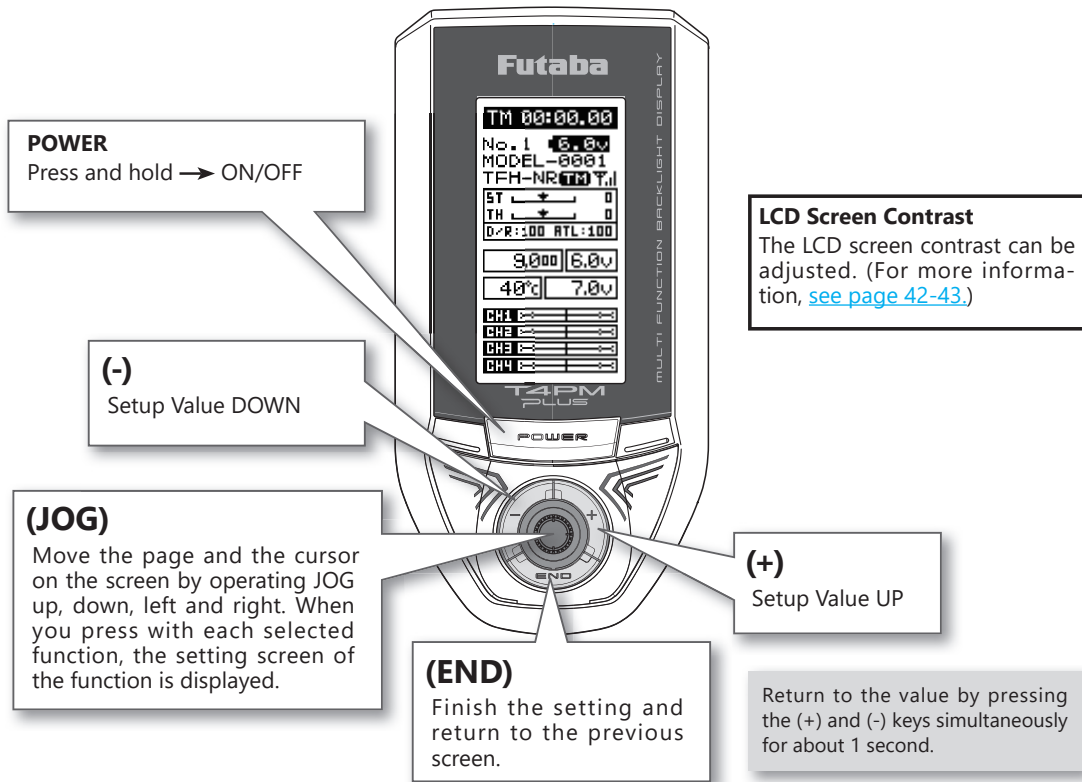

# Display When Power Switch Is Turned On

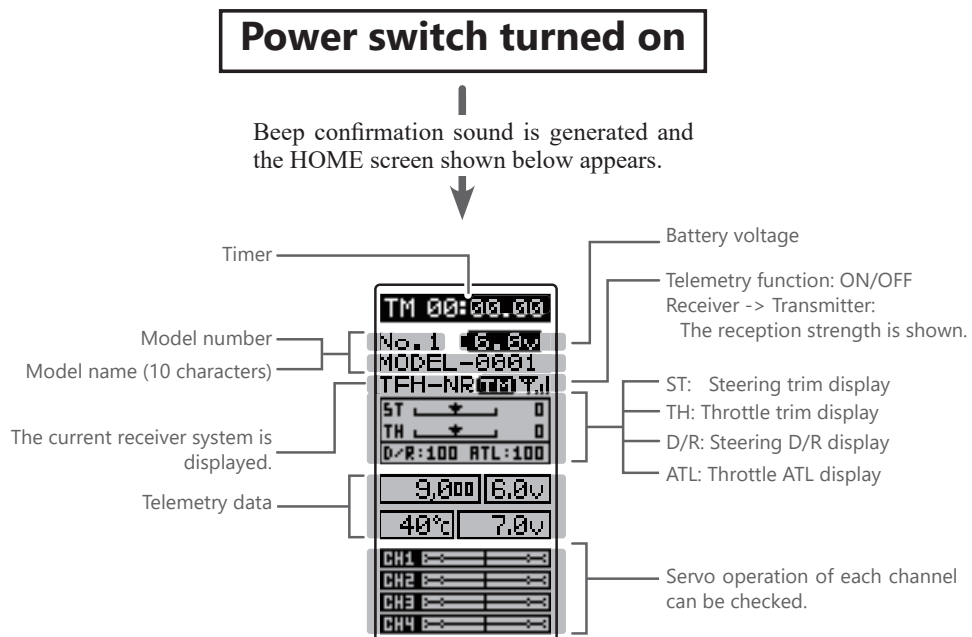

## Power Off Reminder Alarm & Auto Power Off

When the steering wheel, throttle trigger, push switch, or edit button are not operated for 10 minutes (default), an alarm sounds and "NOT OPERATED FOR A LONG TIME" is displayed on the LCD screen.

When the steering wheel, throttle trigger, push switch, or edit button are operated, the alarm is reset. If the alarm is not reset, the auto power off function will automatically turn off the power after 5 minutes. If the system is not to be used, turn off the power.

The function can be deactivated at the system menu ([page 42-44](#)).

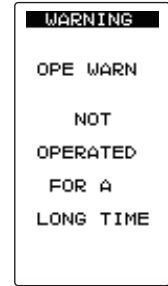

## Steering Wheel And Throttle Trigger Operation

(CH1: Steering wheel, CH2: Throttle trigger)

Steering Wheel Function: Turns the model right or left.

Throttle Trigger Function: Controls the speed of the model as well as the direction of travel - forward or reverse.

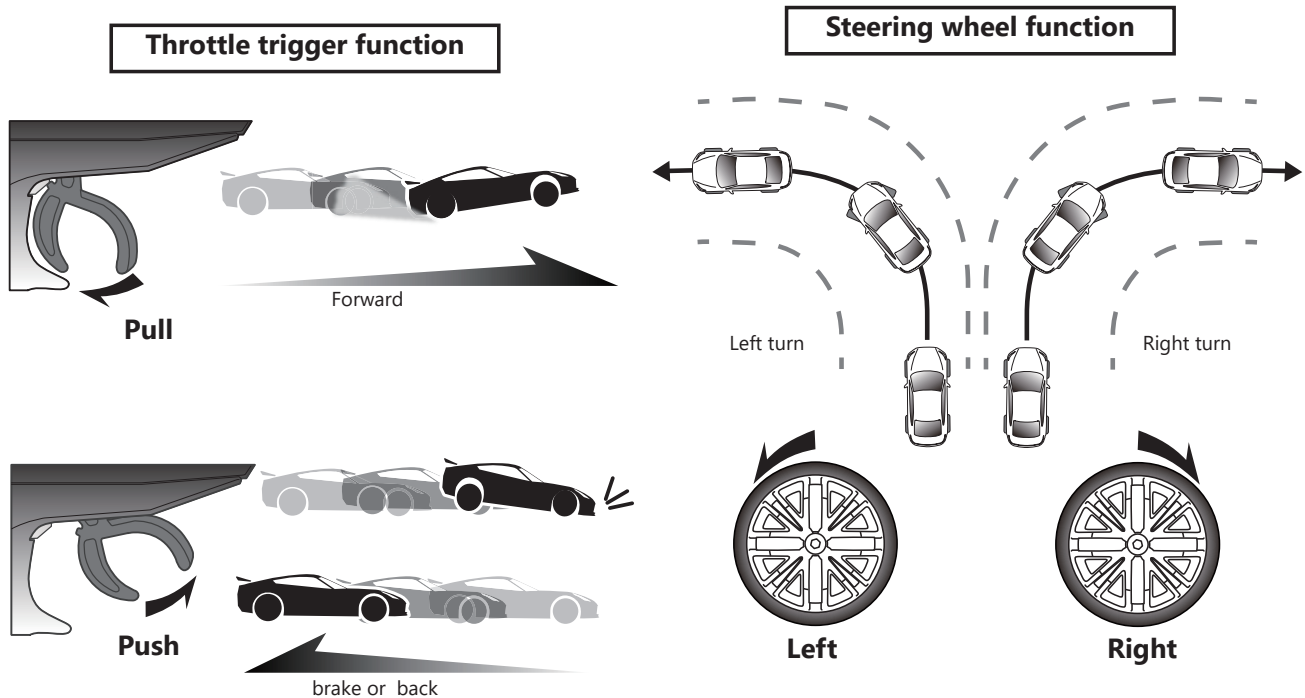

## Digital Trim Operation

(Initial settings: DT1: Steering trim, DT2: Throttle trim, DT3: Channel 3, DT4: Steering D/R, DT5: ATL-Brake rate)

Operating by the trim: Push the trim lever to the left or right (up or down). The current position is displayed on the LCD screen.

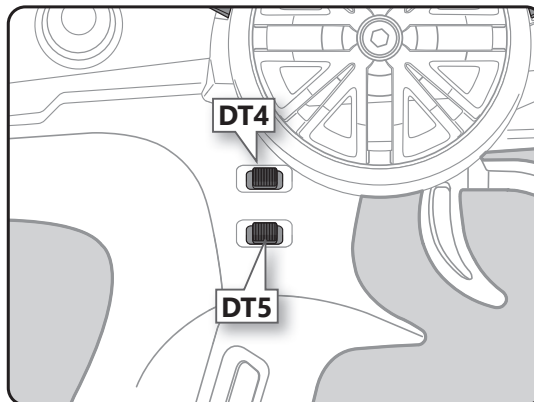
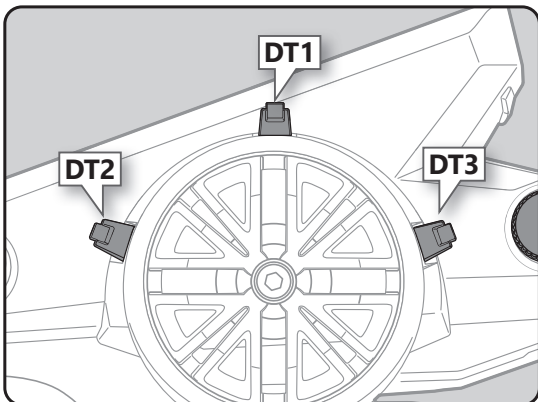

- Each step is indicated by a tone.
- When the trim exceeds the maximum trim adjustment range, the beep will change and the servo will not move any farther.
- Steering D/R: The steering left and right servo travels are adjusted simultaneously.
- ATL: Decreases the set value when the braking effect is strong and increases the set value when the braking effect is weak.

### Steering And Throttle Trim Operation

With the center trim feature, trim adjustments have no effect on the maximum servo travel. This prevents the linkages from binding when adjustments are made.

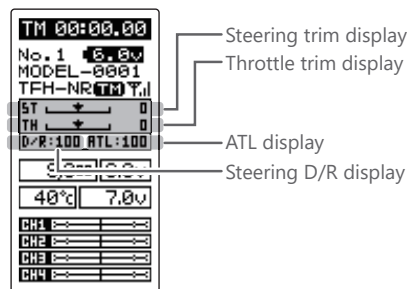

## Mechanical ATL Adjustment

Make this adjustment when you want to decrease the stroke of the brake (back) side of the throttle trigger to your preferences.

### Adjustment

- 1 Using a 1.5 mm hex wrench, adjust the trigger brake (reverse) stroke. (The screw moves the throttle trigger stopper.)

- When the screw is turned clockwise, the stroke becomes narrower. Adjust the stroke while watching the screw.

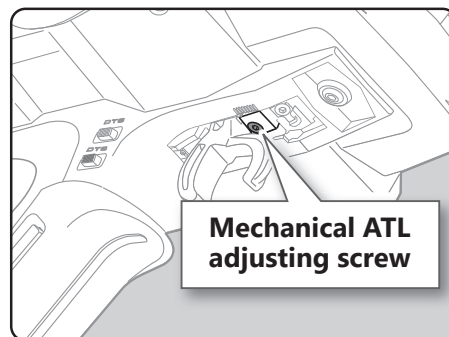

### Note:

Once you have changed the mechanical stroke on the brake side, be sure to adjust the scale of the throttle channel accordingly by using the "Adjuster" function ([page 144-145](#)).

Due to this change, you also need to adjust in most cases the travel of the throttle servo by using "End Point Adjuster".



## Wheel & Trigger Tension Adjustment

Make this adjustment when you want to change the wheel or trigger spring's tension.

### Adjustment

- 1 Using a 1.5mm hex wrench, adjust the spring tension of the wheel or throttle by turning the screw shown in the figure. The wheel side is inside the adjustment hole.

- The spring is set to the weakest tension at the factory.
- When the adjusting screw is turned clockwise, the spring tension increases.

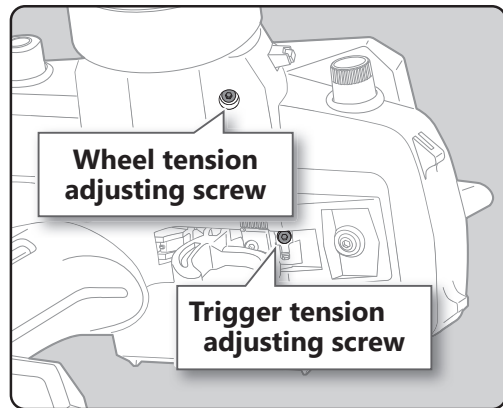

### Note:

The adjustment range is up to 7 to 8 turns from the fully tightened (strongest) position. If turned farther than this, the adjusting screw may fall out.

## Trigger Slide Adjustment

The throttle trigger position can be moved forward and backward.

### Adjustment

- 1 Using a 2.0 mm hex wrench, loosen the trigger slide mounting screw by turning it slightly counterclockwise.

- Always loosen this screw.

### Note:

If the trigger slide screw is turned too much, the screw may fall out.

- 2 Adjust the trigger slide position within the marked range.
- 3 Retighten the mounting screw loosened at step 1 and fasten the trigger slide.

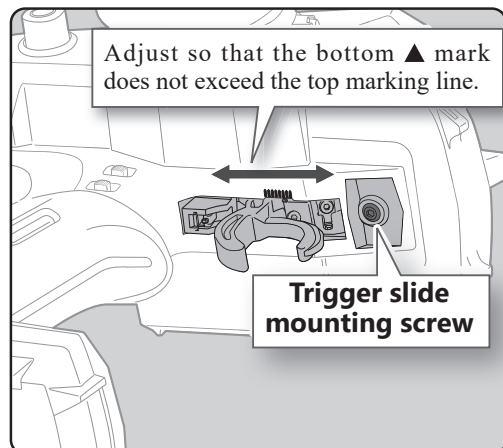

# About Transmitter Antenna and Receiver

## About The Transmitter Antenna

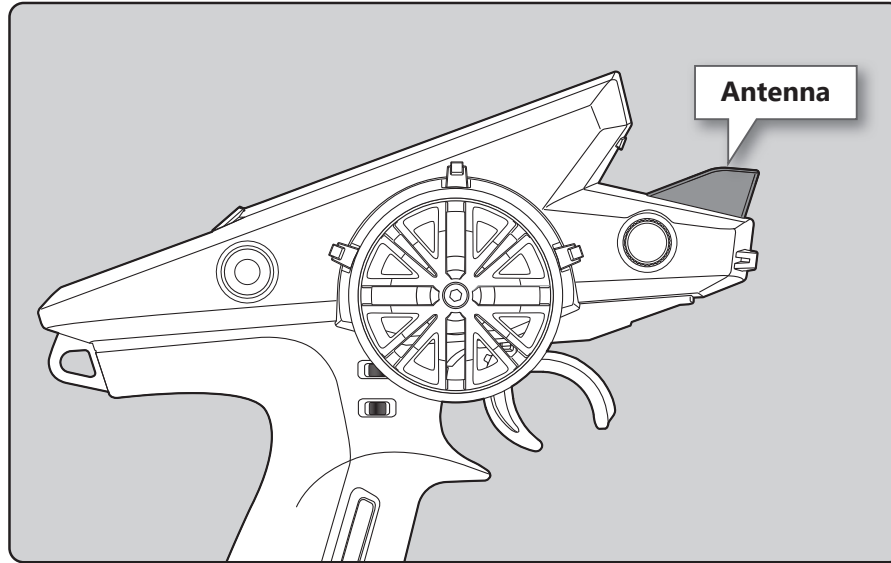

### Warning

⊘ Please do not grasp the transmitter's antenna while driving.  
Doing so may degrade the quality of the RF transmission to the model.

\*A small glitch may occur if the transmitter antenna is brought close to servos, ESCs or other peripheral devices.  
This is not a serious issue, but keep it in mind (especially during setup).

## Receiver Terminology

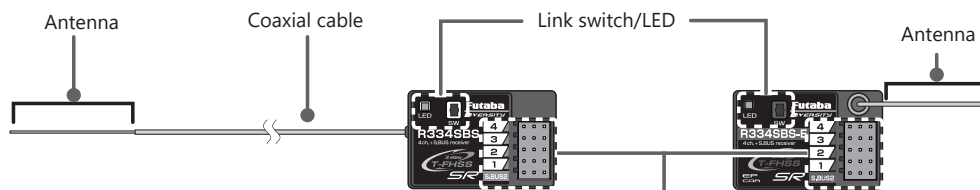

\*The receiver power supply can be connected to the S.BUS2 connector or each of CH1-4.

### Connectors

- 4: CH4 servo (CH4)
- 3: CH3 servo (CH3)
- 2: Throttle servo (CH2)
- 1: Steering servo (CH1)
- S.BUS2: Power /S.BUS2 connector

## Receiver Installation

Install the receiver on the car as follows:

**NOTE:** The R304SB, R334SBS and R334SBS-E receiver operating range may be reduced, depending on where the receiver and the antenna are mounted.

**NOTE:** The R304SB, R334SBS and R334SBS-E receiver are put the antenna in the antenna tube to protect it. Do not let the tip go outside.

**NOTE:** The R334SBS and R334SBS-E receiver of diversity type with both external and internal antennas. Do not place wiring or other objects on the plate. The receiving range may be affected.

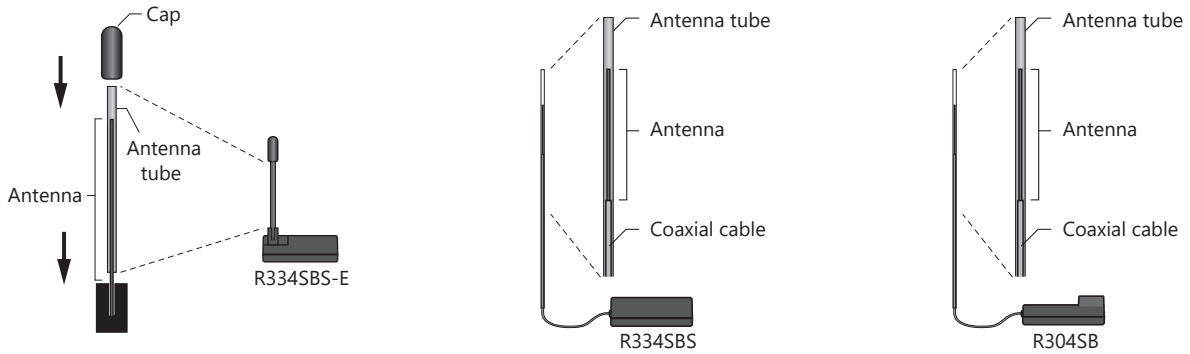

### **WARNING**

- ❗ Install the antenna in the higher place as shown in the figure.
- ⊘ Do not cut or bundle the receiver antenna wire.
- ⊘ Do not bend the coaxial cable. It causes damage.
- ⊘ Do not pull the receiver antenna or coaxial cable by force.
- ❗ Keep the antenna as far away from the motor, ESC and other noise sources as you possibly can.
- ❗ Wrap the receiver with something soft, such as foam rubber, to avoid vibration. If there is a chance of getting wet, put the receiver in a waterproof bag or balloon.
- ❗ Always use R334SBS under the following conditions:
  - Battery: Power requirement Rated voltage 3.8 to 7.4V (dry cell battery cannot be used)  
Matched to the ratings of the receiver and connected servo.
  - Transmitter's receiver system > T-FHSS SR --- SR mode channel (ON): SR mode of Futaba SR compatible servo.
  - Transmitter's receiver system > T-FHSS SR --- SR mode channel (OFF): Normal mode of Futaba SR compatible servo.  
Futaba digital servo.
  - Transmitter's receiver system > T-FHSS/S-FHSS  
Transmitter's response type: Digital servo: Futaba digital servo  
Transmitter's response type: Analog servo: Futaba all servo (Normal mode of Futaba SR compatible servo.)

Under other conditions, the set will not operate, or the specified performance will not be displayed even if it operates. In addition, it may cause trouble with servos and other equipment. Futaba will not be responsible for damage, etc. caused by combination with the products of other companies.

\* Please identify the servo set to SR with the attached SR sticker.



**Receiver and Servo Connections**

Connect the receiver and servos as shown below. Connect and install the receiver and servos in accordance with "Installation Safety Precautions" on the next page.

The figure shown below is an example. The method of connecting the motor controller to the motor and battery depends on the motor controller used. Purchase the motor controller and servos separately. The receiver also depends on the set.

**Installation When An Electronic Speed Control Is Used**

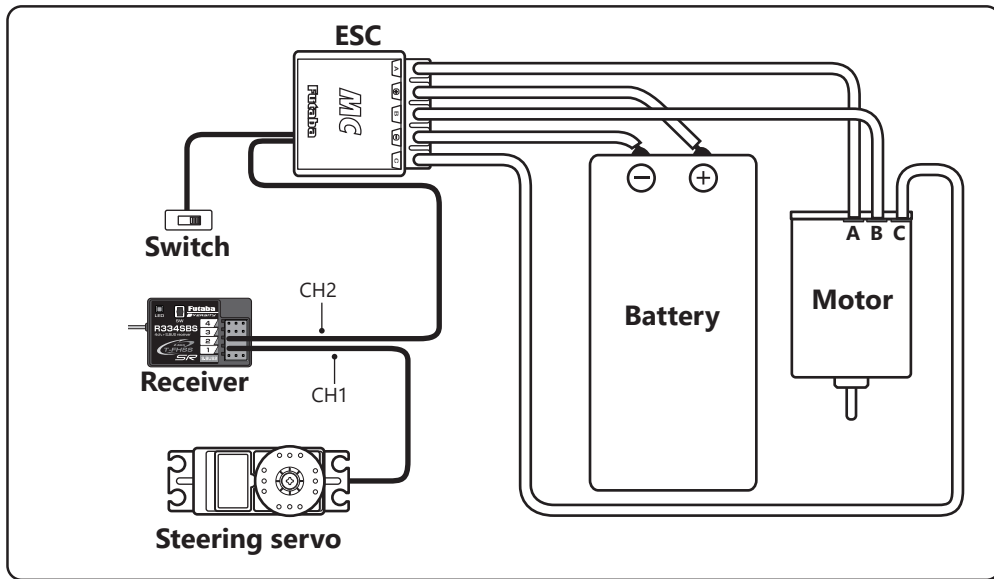

**Installation For Gas Powered Models**

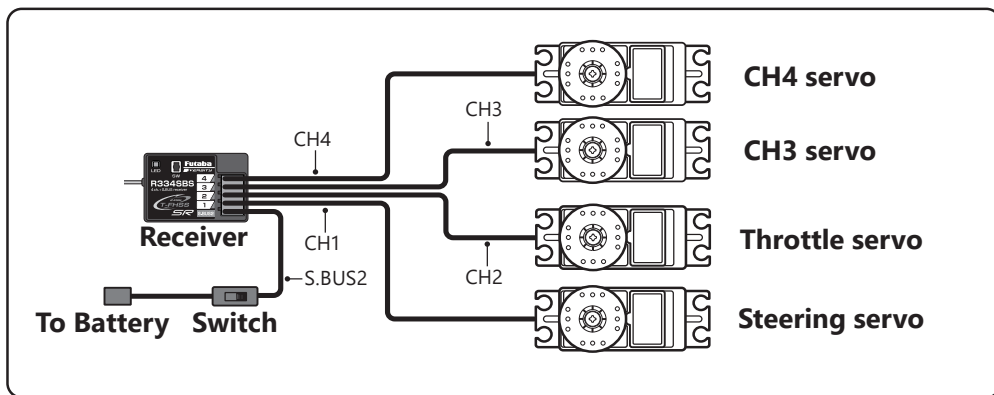

## Connection example of S. BUS using a telemetry sensor

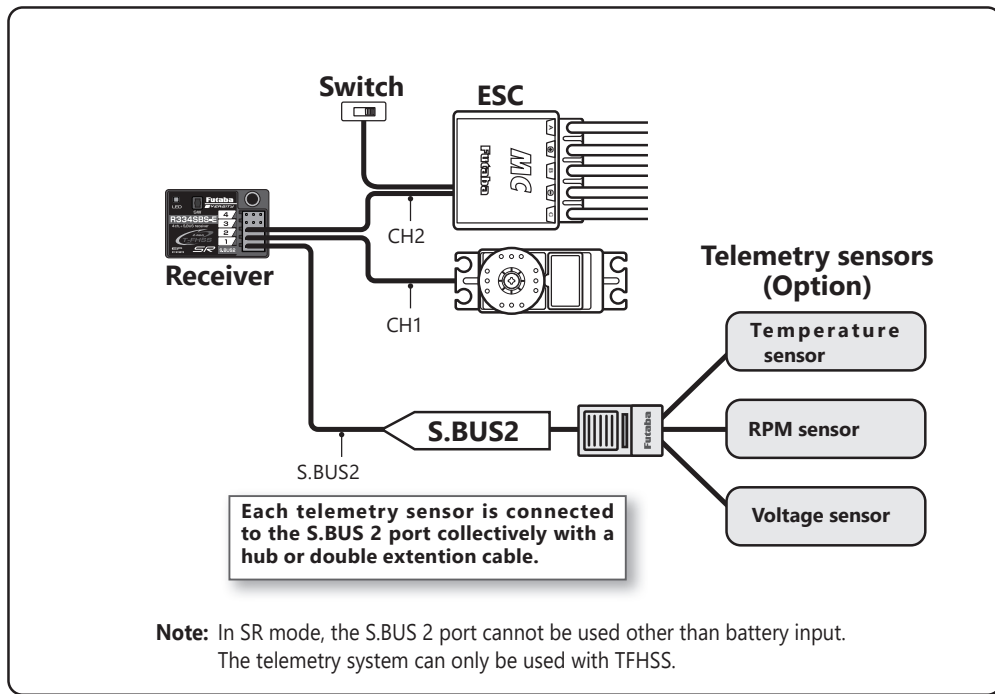

## Installation Safety Precautions

### **Warning**

#### Receiver (receiver antenna)

- ⊘ Do not cut or bundle the receiver antenna wire.
- ⊘ Do not bundle the receiver antenna wire together with the motor controller lead wire.
- ⊘ Keep the receiver antenna wire at least 1 cm away from motor, battery, and other wiring carrying heavy current.
- ⊘ Do not use a metal receiver antenna holder on a plate made of metal, carbon, or other conductive material.
- ⊘ Since the antenna of built-in antenna receivers is installed under this, do not place wiring or other objects on it.
- ❗ Install the receiver antenna holder as closely as possible to the receiver.

If the antenna wire is cut, bundled, or routed near a noise source, the receiving sensitivity will drop, the running (cruising) range will decrease, and you may lose control of the model.

\*Noise is transmitted through metal, carbon, and other conductive material, so keep the receiver antenna wire away from such parts.

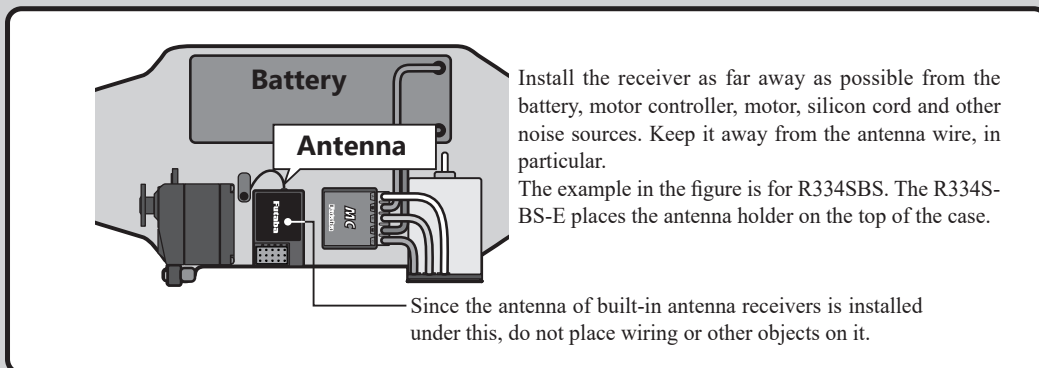

## Warning

### Receiver Vibration-proofing / Waterproofing

- ❗ For dustproof and waterproof measures, attach the attached dustproof rubber cap to the empty channel of the receiver.

(Car)

- ❗ Vibration-proof the receiver by wrapping it in foam rubber or other vibration-absorbing material and mount it with thick double-sided tape.
- ❗ When using the receiver holder supplied with the model kit, mount the holder to the chassis through a rubber grommet.

(Boat)

- ❗ Vibration-proof the receiver by wrapping it in foam rubber or other vibration-absorbing material. Also waterproof the receiver by cruising it in a plastic bag.

If the receiver is exposed to strong vibration and shock, or the ingress of water, it may not operate correctly and you may lose control of the model.

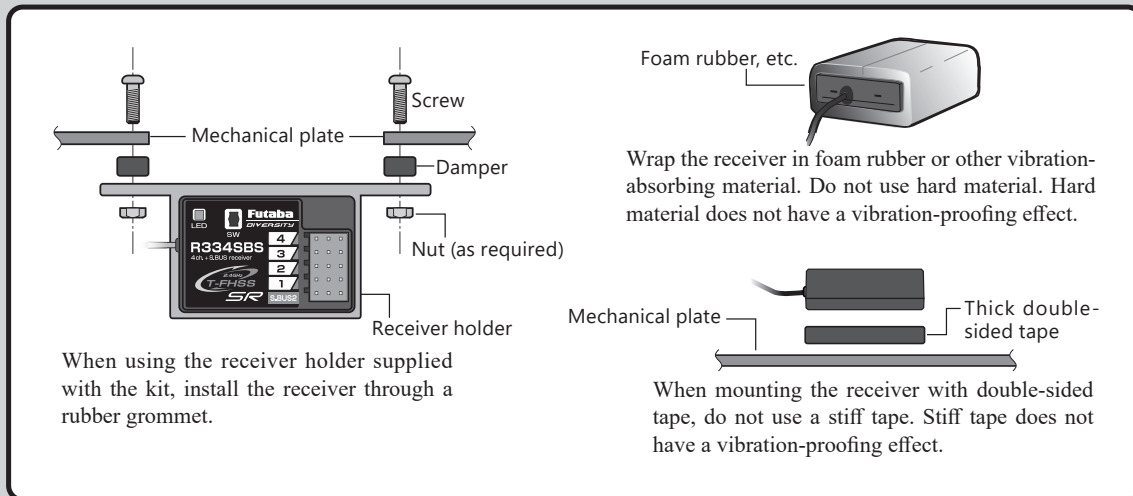

### Connector Connections

- ❗ Be sure the receiver, servo, battery and connectors are fully and firmly connected.

If vibration from the model causes a connector to work loose while the model is in operation, you may lose control.

### Servo Installation

- ❗ When you install the servos, always use the rubber grommets provided in servo hardware bags. Mount the servos so they do not directly come in contact with the mount.

If the servo case comes in direct contact with the mount, vibration will be directly transmitted to the servo. If this condition continues for a long time, the servo may be damaged and control will be lost.

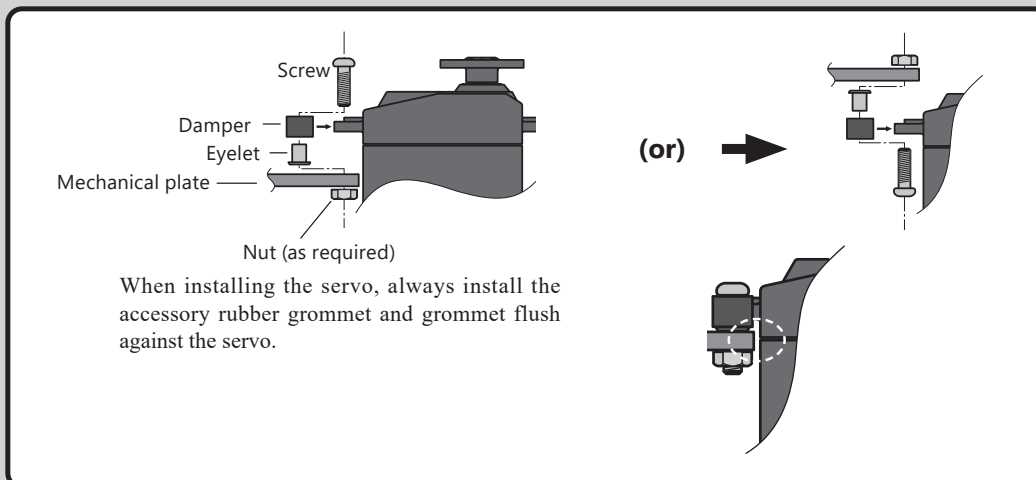

## **Warning**

### **Servo Throw**

- ❗ Operate each servo over its full stroke and be sure the linkage does not bind or come loose.

The continuous application of unreasonable force to a servo may cause damage and excessive battery drain.

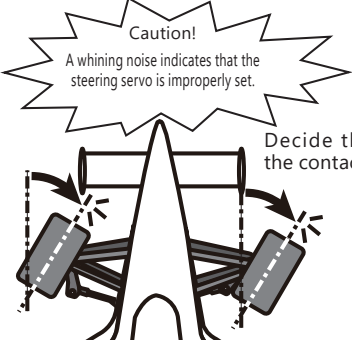

Caution!  
A whining noise indicates that the steering servo is improperly set.

Decide the EPA value at the contact point.

Adjust the steering servo so that unreasonable force is not applied to the servo by the chassis at maximum servo travel.

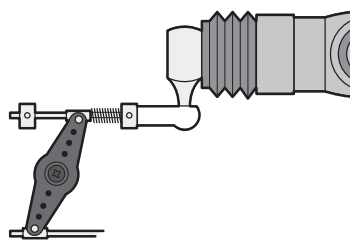

Adjust the throttle servo so that unreasonable force is not applied when the engine carburetor is fully open, fully closed, and the brakes are applied fully.  
If the brakes overheat while running, their ability to function properly decreases. Before running, adjust the suitable maximum servo travel so that unreasonable force is not applied even when the servo travel is increased while running.

## **Warning**

### **Electronic Speed Control**

- ❗ Install the heat sinks where they will not come in contact with aluminum, carbon fiber or other parts that conduct electricity.

If the ESC (Electronic speed control) heat sinks touch other materials that conduct electricity a short circuit could occur. This could result in loss of control and damage to the system.

### **Motor Noise Suppression**

- ❗ Always install capacitors to suppress noise when electric motors are used.

If capacitors are not properly installed you could experience erratic operation and reduced range as well as loss of control.

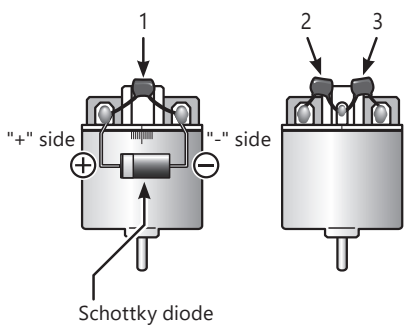

1  
2 3

"+" side  
"-" side

Schottky diode

Motors with no suppressor capacitors, or inadequate suppression, may cause the receiver to malfunction. Always solder the capacitors supplied to your motor.  
The Schottky diode improves the efficiency of the speed control / motor combination and provides extra protection to the brake FETs. The white ring must always face the positive side.

### **Other Noise Suppression Methods**

- ❗ Be sure there are no metal parts in your model which under vibration can come in contact with other metal parts.

Metal to metal contacts under vibration will emit a high frequency noise that will affect the receiver's performance. You could experience erratic operation and reduced range as well as loss of control.

**Preparations (Transmitter)**

Before setting the Transmitter functions, check and set these items next.

**(Display when power switch turned on)**

When the power switch is turned on, the currently selected model number is displayed. Check if this number is the model number you want to set-up. To change the model number, use [the Model Select function \(page 74\)](#).

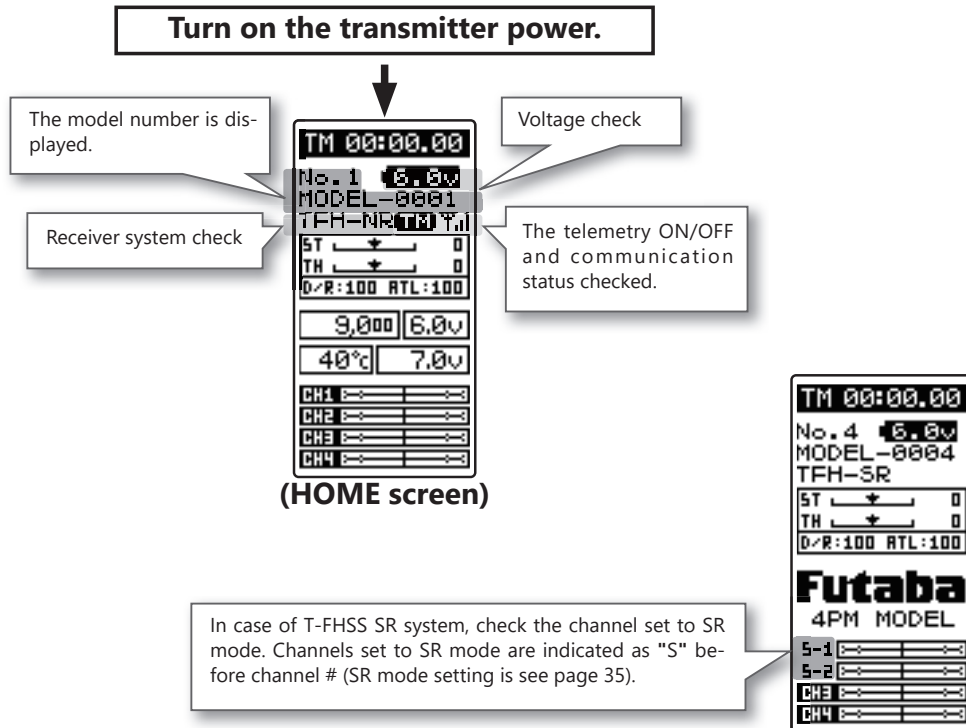

**Receiver System Check (RECEIVER)**

This system sets the Receiver system of the transmitter to match the receiver and servos used. The T4PM PLUS transmitter uses the telemetry type T-FHSS ("TFH") system or T-FHSS SR ("TFH-SR") system.

It can also use the conventional S-FHSS ("SFH") system.

Since the R334SBS and R334SBS-E receivers supplied with the T4PM PLUS set uses the T-FHSS SR (Super response) or telemetry function T-FHSS system, T4PM PLUS receiver setup must be set to the T-FHSS high speed system ("TFH-HI"), the T-FHSS normal system ("TFH-NR") or T-FHSS SR ("TFH-SR").

Since the T-FHSS SR system cannot be used for R304SB, R304SB-E receivers, set it to the T-FHSS high speed system ("TFH-HI") or the T-FHSS normal system ("TFH-NR").

The RA-42 receiver for Futaba exclusive to Kyosho Mini-Z Evo can be used for T4PM PLUS transmitter. When using it, set it to the MINIZ system.

\* Refer to page 33 for cautions on each system and servo to be used.

If the receiver used and the Receiver system settings are different, change the Receiver system using the "RECEIVER" function. Which Receiver system is set can be checked at the HOME screen.

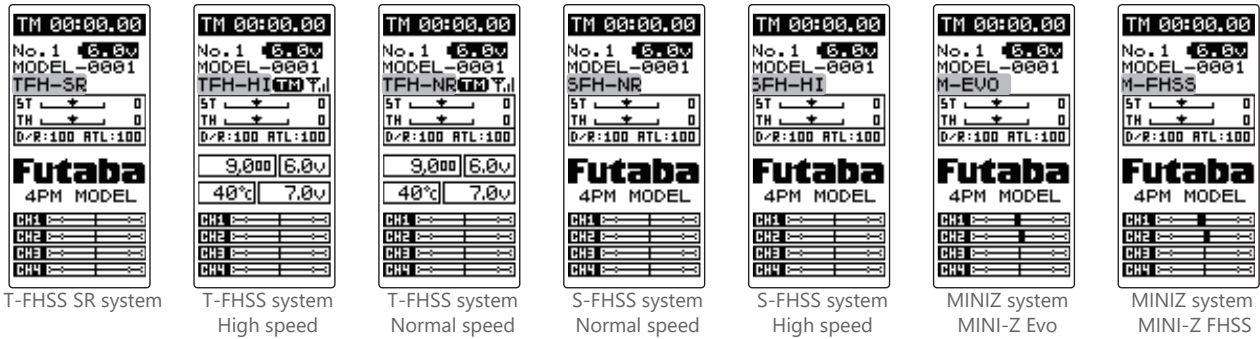

## Receiver System Change & How To Link

The first operation described below sets the Receiver system. Next, the transmitter and receiver are linked and the transmitter ID number is memorized at the receiver so that signals from other transmitters will not be received. The telemetry type T-FHSS also simultaneously memorizes the ID number of the receiver at the transmitter so that data from other receivers will not be received.

The Receiver system setting and transmitter and receiver linking methods are described here. Refer to the figure at the right for the edit buttons used.

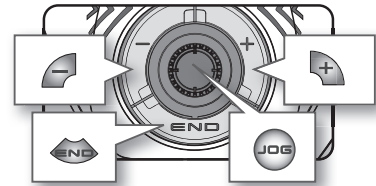

- 1 Call the MENU 2 screen from the HOME screen by moving the (JOG) button up, down, left or right. Select "RECEIVER" by moving the (JOG) button up or down, and display the "RECEIVER" screen by pressing the (JOG) button. When using the MINI-Z / FHSS, insert the FS-RM005 module before turning on the power. ([See page 33](#))

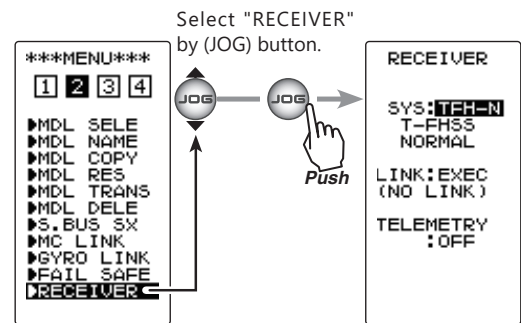

- 2 Move the cursor to "SYS: ----" by the (JOG) button up or down operation, and select the Receiver system with the (+) button or (-) button. (Refer to [pag 35](#) for the combination of servo mode and servo.) When the (JOG) button is pressed for approximately 1 second, an electronic sound is generated and setting ends.

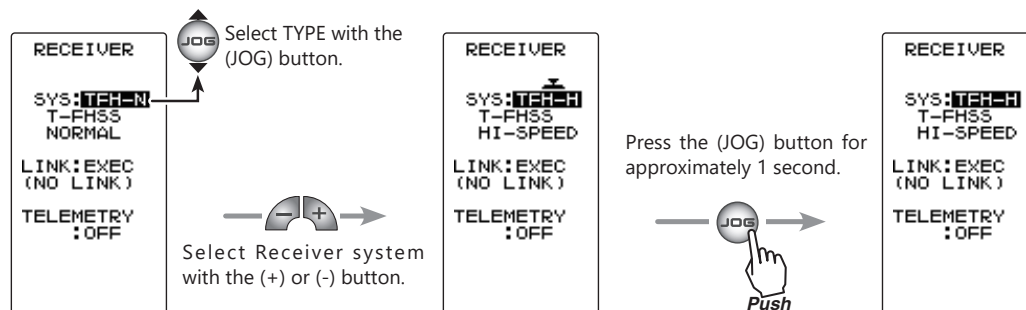

\*When using an S-FHSS system ("SFH") receiver (R2104GF, R204GF-E, etc.), after reaching this point set the transmitter power switch to OFF and go to ["Receivers Other Than T-FHSS" on page 32.](#)

For [Kyosho MINI-Z receivers](#), see pages 33-34.

**3** Bring the transmitter and receiver to 20 inches (half meter) of each other (do not allow the antennae to touch) and turn on the receiver power.

**4** Press the T4PM PLUS transmitter's (JOG) button up or down to move the cursor to "LINK: EXE".

When the (JOG) button is pressed for approximately 1 second, "PUSH RX LINK SW" appears on the screen and a 20 second countdown begins. Countdown can be canceled at any time pressing the (JOG) button up / down or left / right.

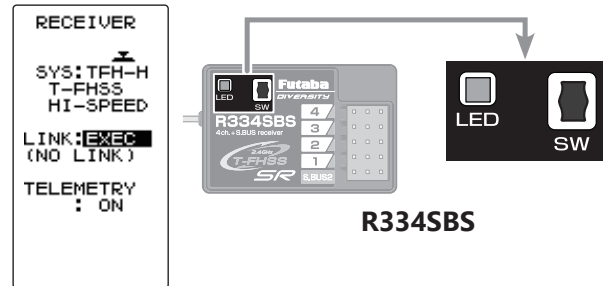

**5** During the 20 second countdown, push up the receiver side Link switch for approximately 2 seconds. The LED will begin to blink red. After the receiver LED switches from blinking red to green - red - green steady light, the T4PM PLUS generates an electronic beeping sound, and "LINK:OK" and "COMPLETE!" appear on the screen. Reading of the mutual IDs ends and the memorized receiver ID number appears on T4PM PLUS screen. If an "TIME OUT" screen appears, linking failed. Retry linking. If the transmitter and receiver are linked normally, set the power switch to the OFF position and then return it to the PWR ON position. If the receiver LED lights green, linking was successful. Now check servo operation.

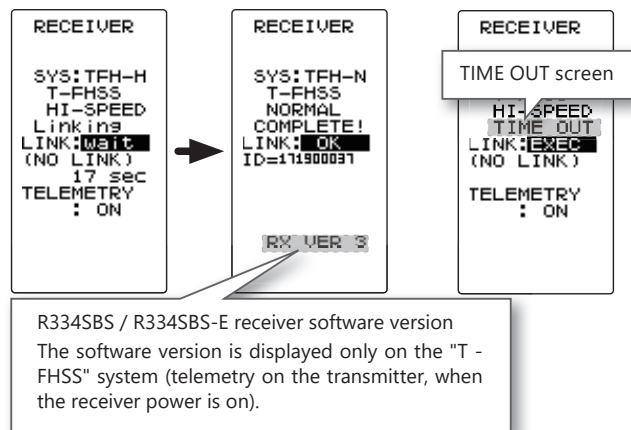

\*The T4PM PLUS and a telemetry type T-FHSS receiver (R334SBS, etc.) mutually memorize the combined ID linked last at each model memory.

Since the T4PM PLUS can memorize only 1 receiver ID at each model memory, multiple T-FHSS receivers cannot be used with the same model memory. When changing the receiver at the same model memory, re-link the previously linked receiver.

When using multiple telemetry type T-FHSS receivers, link and combine them with each T4PM PLUS model memory.

However, multiple receivers cannot be linked to multiple model memories.

The telemetry function communications status can be checked at the HOME screen.

The telemetry ON/OFF and communication status can be checked at the HOME screen.

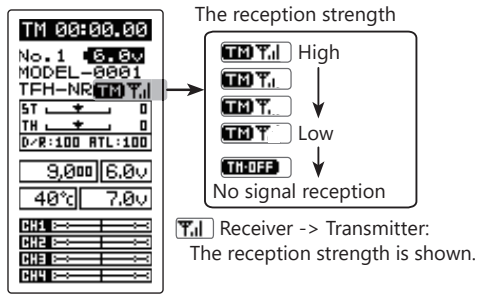

- Telemetry function :ON
- Receiver ID setting complete
- Data receiving sensitivity display
- **TM OFF** shows that data cannot be received because it is outside the data receiving range or because of the effects of an obstruction or the receiver power is OFF after receiver ID check.

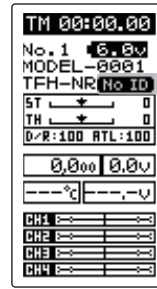

- Telemetry function :ON
- Receiver ID before setting or ID mismatch.
- When the receiver ID is set, before ID check in the receiver power OFF stat.

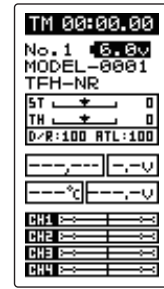

Telemetry function :OFF

## Receivers Other Than T-FHSS

- 1 Bring the transmitter and the receiver close to each other, within 20 inches (half meter).
- 2 Turn on the transmitter.
- 3 Turn on the receiver.
- 4 Push the Link switch of the receiver.  
When the link is complete, the LED in the receiver changes to solid green.

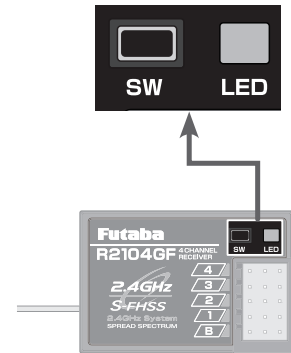

\*Please refer to the table below for LED status vs receiver's condition.

LED status vs receiver's condition:

No signal reception	Red : On
Receiving signals	Green: On
Receiving signals, but ID is unmatched.	Green: Blink *1 (T-FHSS ,Red : On)
Unrecoverable failure (EEPROM,etc.)	LED: Red and Green turn on alternately

\*1: LED could be change to red during intermittently during data processing.





## Kyosho Mini-Z FHSS

With the T4PM PLUS powered off, insert the FS-RM005 module as shown.

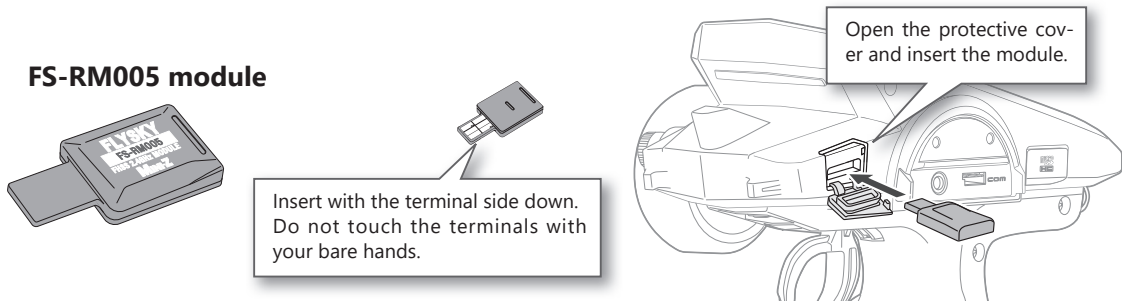

- 1 Turn on the T4PM PLUS and change the receiver system (page 30) to set it to MINI-Z / FHSS (MFHSS). Bring the transmitter and the receiver close to each other, within 20 inches (half meter). Turn on the receiver.
- 2 Call the MENU 2 screen from the HOME screen by moving the (JOG) button up, down, left or right. Select "RECEIVER" by moving the (JOG) button up or down, and display the "RECEIVER" screen by pressing the (JOG) button.
- 3 Turn on the power while pressing the link switch of the MINI-Z receiver. Release the link switch.

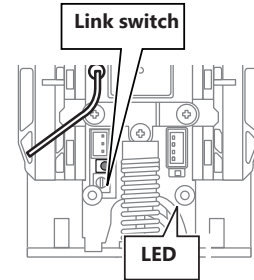

- 4 The LED on the MINI-Z receiver will blink.  
Press the T4PM PLUS transmitter's (JOG) button up or down to move the cursor to "LINK: EXE". When the (JOG) button is pressed for approximately 1 second, "Wait" appears on the screen and a 20 second countdown begins. Operate the (JOG) button up and down to cancel the link mode of the transmitter.

If you set the RX system to MINI-Z FHSS (MFHSS), you can adjust the "Steering force" and "Gyro gain" on this "RECEIVER" screen.

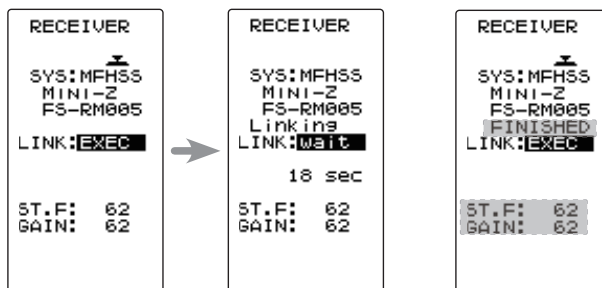

### Setup item

ST.F: Steering force  
GAIN: Gyro gain

### ST.F:

0~100: Initial value: 62

### GAIN:

0~100: Initial value: 62

### Adjustment buttons

- Use the (+) and (-) buttons to make adjustments.
- Return to the initial value by pressing the (+) and (-) buttons simultaneously (approx. 1 sec).

### Dial / Trim Setting

The "Steering force" and "Gyro gain" can be adjusted by using the trim dial function ([page 104](#)).

- 5 When the link is complete, LED of Mini-Z receiver, blink → Solid. Please check the operation.

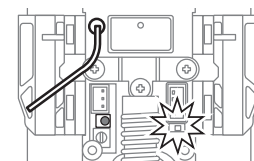

## Kyosho Mini-Z EVO dedicated receiver RA-42

- 1 Bring the transmitter and the receiver close to each other, within 20 inches (half meter). Turn on the receiver.
- 2 Turn on the transmitter.
- 3 Turn on the Mini-Z receiver RA-42.
- 4 Press the T4PM PLUS transmitter's (JOG) button up or down to move the cursor to "LINK: EXE". When the (JOG) button is pressed for approximately 1 second, "Wait" appears on the screen and a 20 second countdown begins. Countdown can be canceled at any time pressing the (JOG) button up, down or left, right.
- 5 Push the receiver side push switch for about 2 seconds or more and release the Link SW. LED of Mini-Z receiver RA-42, 2 seconds solid → Blink

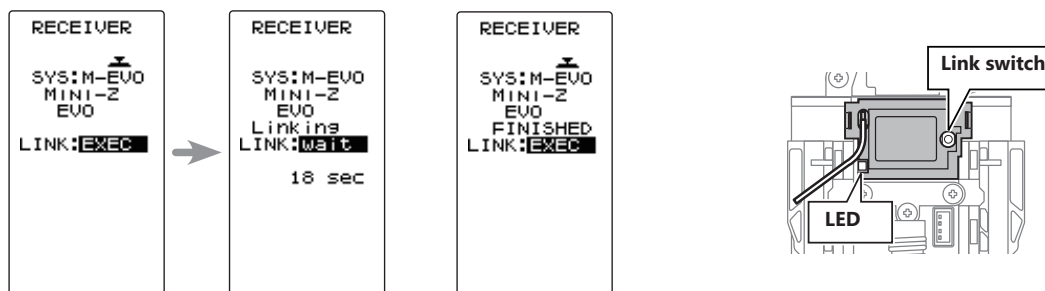

Touch the [END] button on the link screen of the transmitter to cancel the link mode. Please check the operation.

- 6 Completed with LED solid the receiver. Please check the operation.

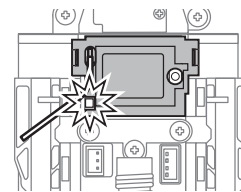

### Warning

- ❗ After the linking is done, please cycle receiver power and check if the receiver to be linked is really under the control of your transmitter.

If there are many Futaba 2.4GHz systems (T-FHSS SR / T-FHSS / S-FHSS / MINIZ) turned on in close proximity to your receiver might not link to your transmitter. In this case, even if the receiver's LED stays solid green, unfortunately the receiver might have established a link to one of other transmitters. This is very dangerous if you do not notice this situation. In order to avoid the problem, we strongly recommend you to double-check whether your receiver is really under control by your transmitter by giving the stick input and then checking the servo response.

- ❗ Do not perform the linking procedure with motor's main wire connected or the engine operating as it may result in serious injury.



## How to set the SR mode Channel

In the case of T-FHSS SR, "SR mode" which has greatly improved response compared to the conventional T-FHSS can be used. The display changes when you change it. Be sure to turn off the power of the receiver before operation check.

In SR mode, ON/ OFF can be set for each channel. When using normal servo or ESC, set the SR mode of the connected channel to (OFF).

**Note:** In SR mode ON, normal servo, ESC and gyro will not operate. Please set our S.BUS servo corresponding to SR mode to SR mode on S.BUS servo menu and use it. Also, in case of SR mode OFF, the servo set to SR mode cannot be used, so set the servo to normal mode by S. BUS servo menu. If using wrong combination, servo and other equipment will fail, so please be careful.

\*Refer to country distributor WEB for detailed the "S. BUS servo menu" and the "SR mode setting" explanation.

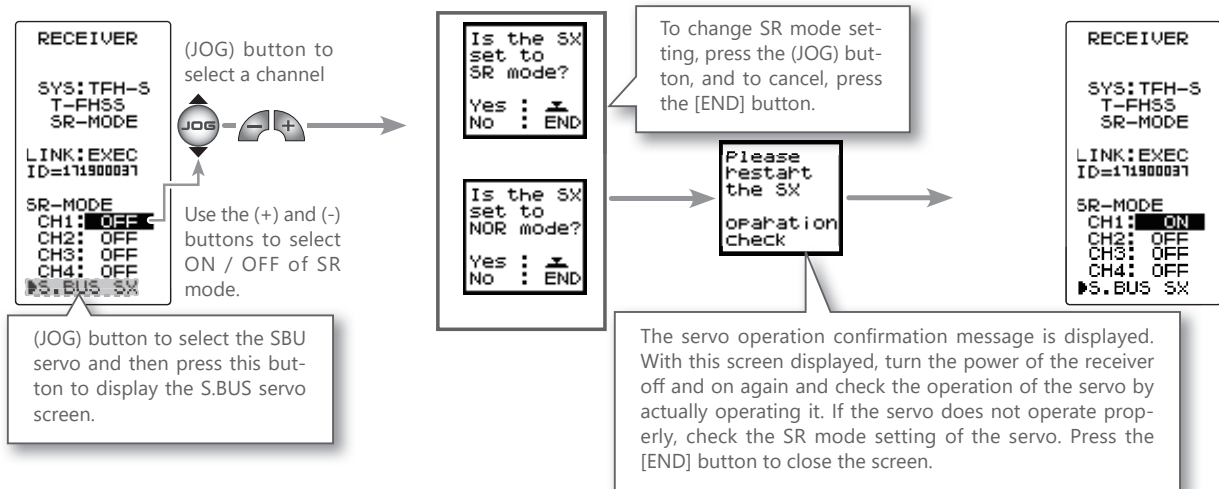

## Servo mode setting and corresponding servo of each system

System	Response / SR mode	Usable servos
T-FHSS SR	SR mode channel: ON	-SR mode of Futaba SR compatible servo.
	SR mode channel: OFF	- Normal mode of Futaba SR compatible servo. - Futaba digital servo.
T-FHSS	HI-SPEED mode	- Normal mode of Futaba SR compatible servo. - Futaba digital servo.
	NORMAL mode	- Futaba all servo. (Normal mode of Futaba SR compatible servo.)
S-FHSS	HI-SPEED mode	- Normal mode of Futaba SR compatible servo. - Futaba digital servo.
	NORMAL mode	- Futaba all servo. (Normal mode of Futaba SR compatible servo.)

### Caution

- ❗ Be sure to use the T4PM PLUS receiver setting and the servo to be used under predetermined conditions.

Under other conditions, the set will not operate, or the specified performance will not be displayed even if it operates. In addition, it may cause servo trouble. Futaba will not be responsible for problems caused by the use of other than Futaba genuine parts. Use the parts specified in the instruction manual and catalog.

## Throttle Mode Check

The throttle servo travel can be set to 5:5 or 7:3 for throttle trigger operation as required by the throttle mode function ([page 63](#)).

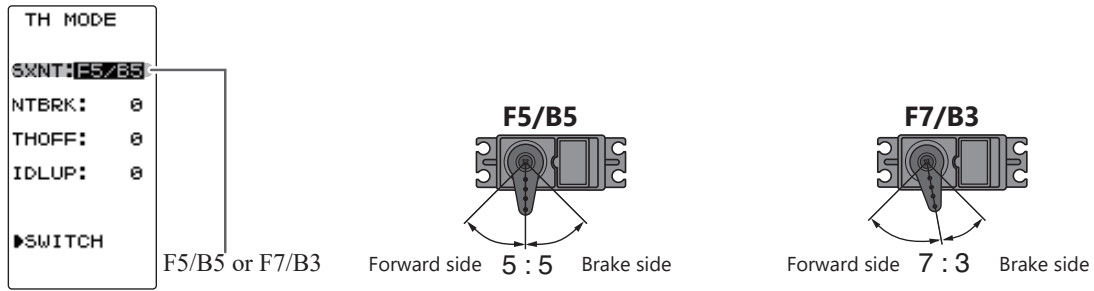

## Trims Initial Set-Up

### - Steering trim (DT1) check

On the initial set-up, steering trim is assigned to the DT1 trim lever upper side of the steering wheel. Operate the DT1 and make sure the marker moves on the ST graph. If default has been changed, test steering trim in its new location. After checking the trim, set the trim display to the center (N) position.

### - Throttle trim (DT2) check

On the initial set-up, throttle trim is assigned to the DT2 trim lever left side of the steering wheel. Operate the DT2 and make sure the marker moves on the TH graph. If the default has been changed, test the throttle trim in its new location. After checking the trim, set the trim display to the center (N) position.

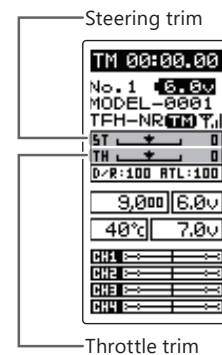
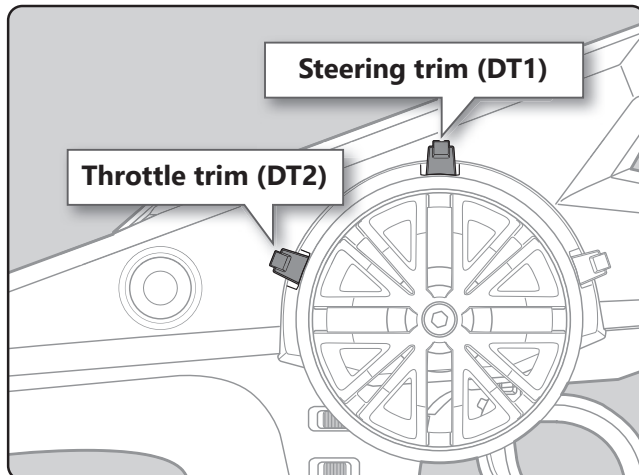

### - Steering dual rate (DT4) check

At initial set-up, steering dual rate (D/R) is assigned to the DT4 trim lever, at the grip of the transmitter. Operate the DT4 and check if the D/R value displayed on the screen changes. After checking D/R, set the steering dual rate to 100%.

### - Throttle ATL (DT5) check

At initial set-up, throttle ATL (ATL) is assigned to the DT5 trim lever, below the DT5. Operate the DT5 and check if the ATL value displayed on the screen changes. After checking ATL, set throttle ATL to 100%.

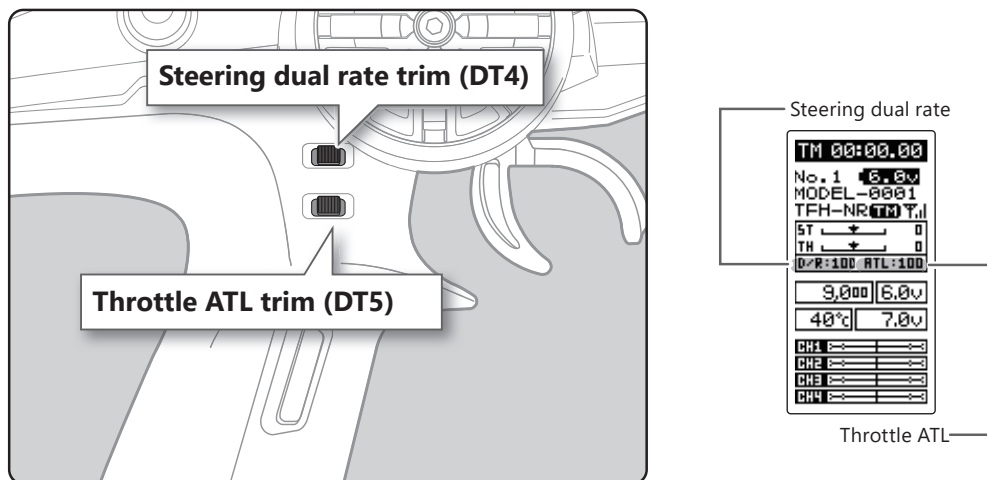

### (Set-Up Procedure When Installed In a Car)

When installing the servos in a car, performing function set-up in the following order is recommended.

- 1** Perform to "Trims Initial Set-Up" of "Preparations" on the preceding page.
- 2** Set the servo direction of operation using the Reverse function. [\(page 46\)](#)
  - The servo installation method and linkage direction depend on the kit. Therefore, the servo operation direction may have to be reversed relative to transmitter operation. Before installing the servo, check the operating direction and set it using the Reverse function.
- 3** Set the subtrim and adjust the servo neutral point. [\(page 47\)](#)
- 4** Set the trigger travel by adjusting the throttle trigger mechanical ATL to your liking. [\(page 21\)](#)
  - When the stroke was adjusted, compensate the throttle by adjuster function. [\(page 144-145\)](#)
- 5** Set End point of each channel and adjust the servo throw (travel). [\(page 48\)](#)



**Operation Of Screen**

In this instruction manual, Edit Buttons are represented by the symbols shown below. The (JOG) button can be operated in 4 directions: up, down, left, and right.

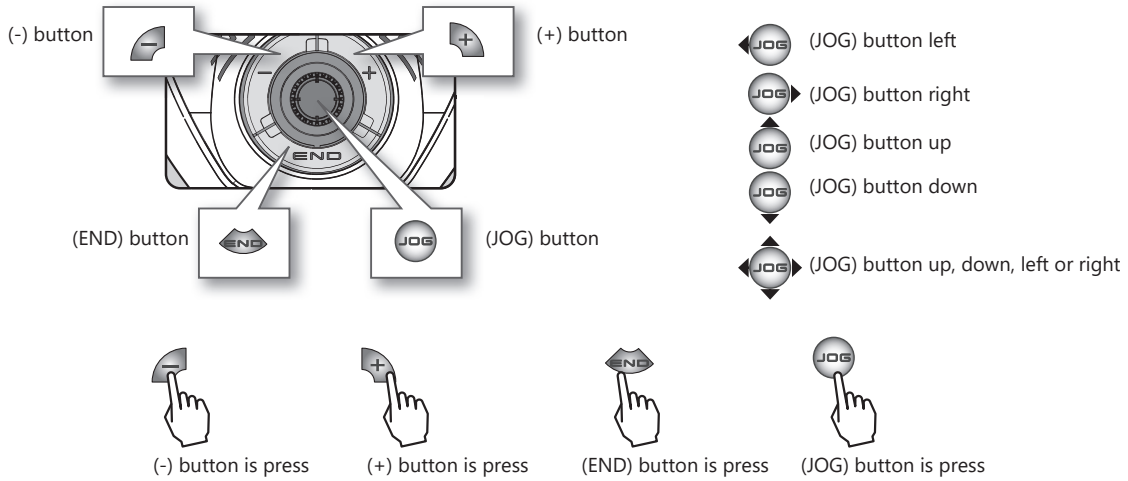

**Calling The Menu Screen**

Refer to the map below for the method of displaying the function setting menu screen from the HOME screen and the method of returning from the menu screen to the HOME screen.

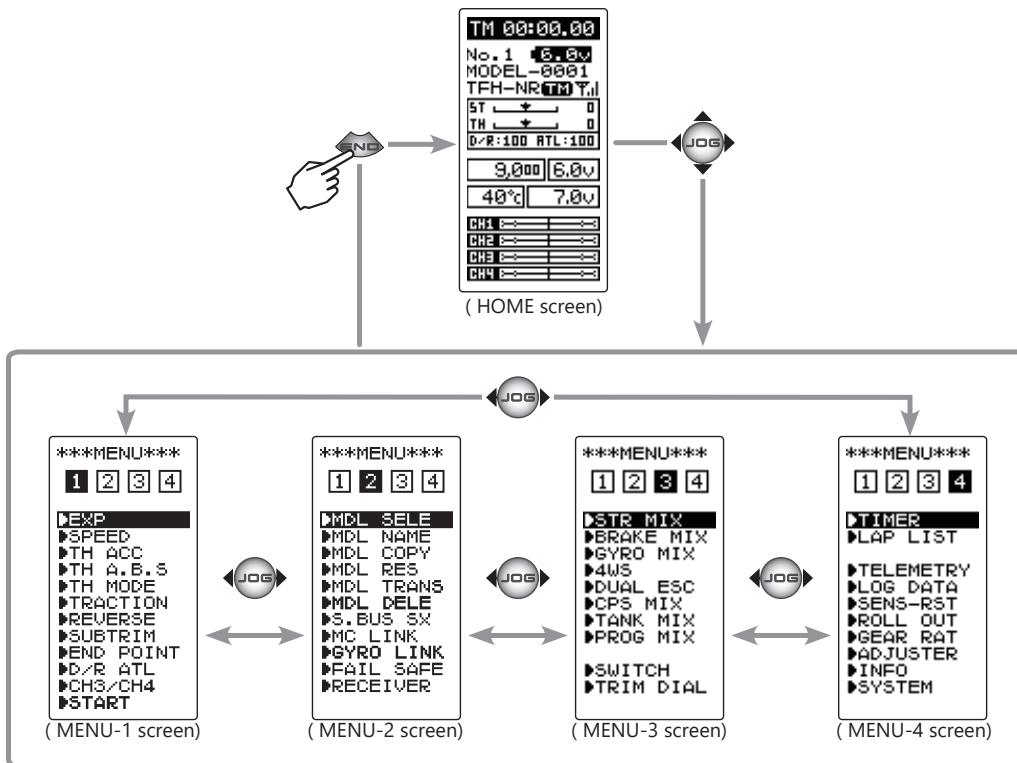

## Selecting Items On The Menu Screen

The item indicated by the reverse displayed cursor on the screen is selected.

The cursor is moved by (JOG) button in up or down movements. The cursor movement figure shown below is an example of the MENU 1 screen. However, movement of the cursor is the same in all of the screens.

For instance, if the (JOG) button is pressed when the cursor is at the end point (END POINT) on the MENU 1 screen, the end point (END POINT) function setting screen appears.

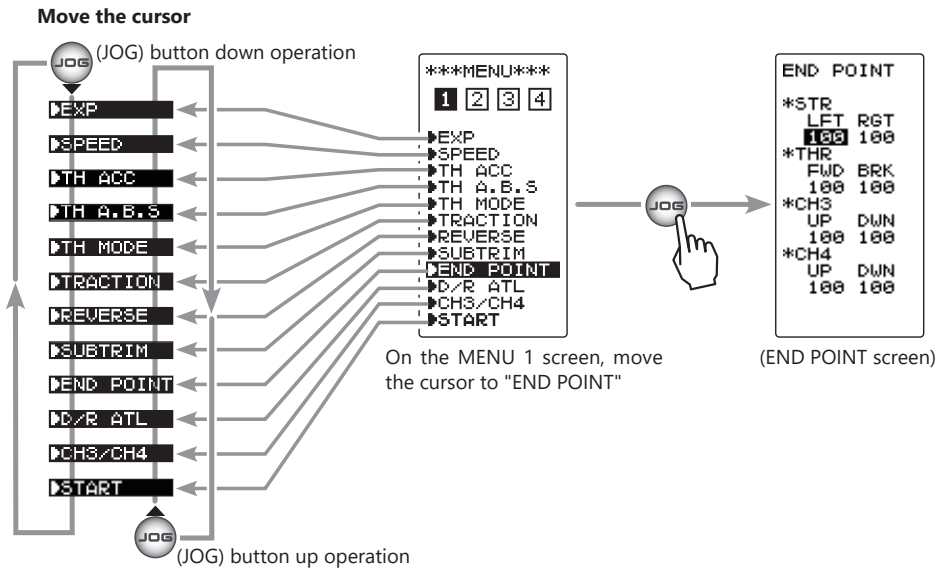

## Value Of Each Function And Changing The Set Value

Values, settings, and other data on all the function setting screens are changed with the (+) and (-) buttons.

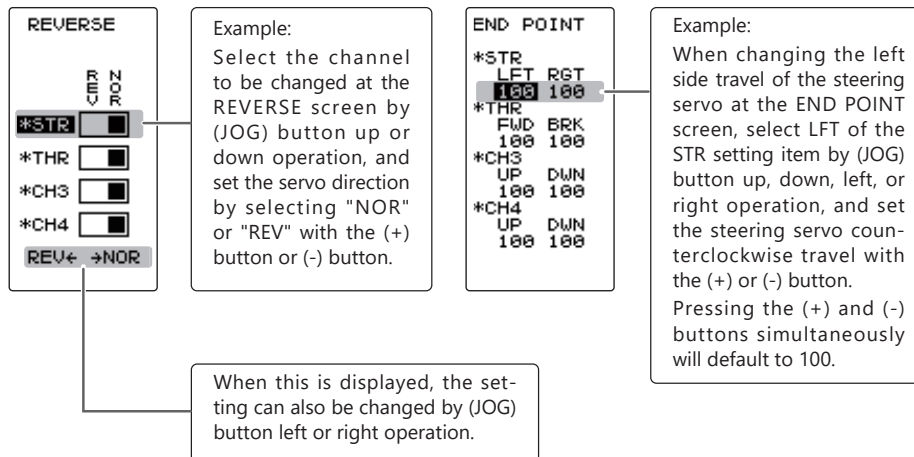

# Basic Menu Japanese Katakana Character Display

On the system menu, the basic menu screen shown below can be displayed in Japanese katakana characters.

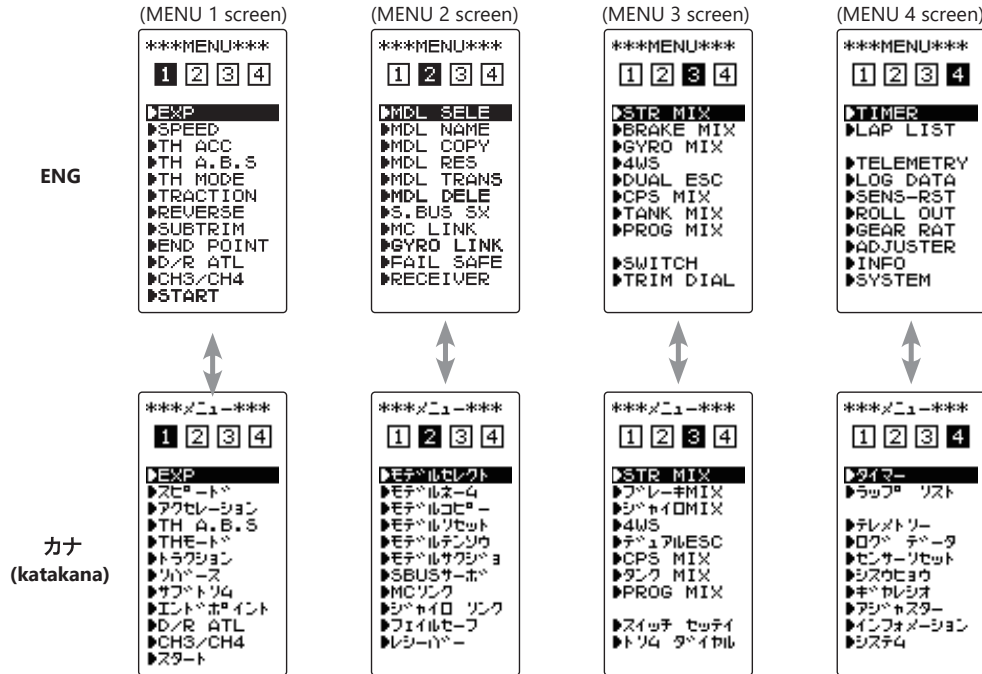

## Changing the character

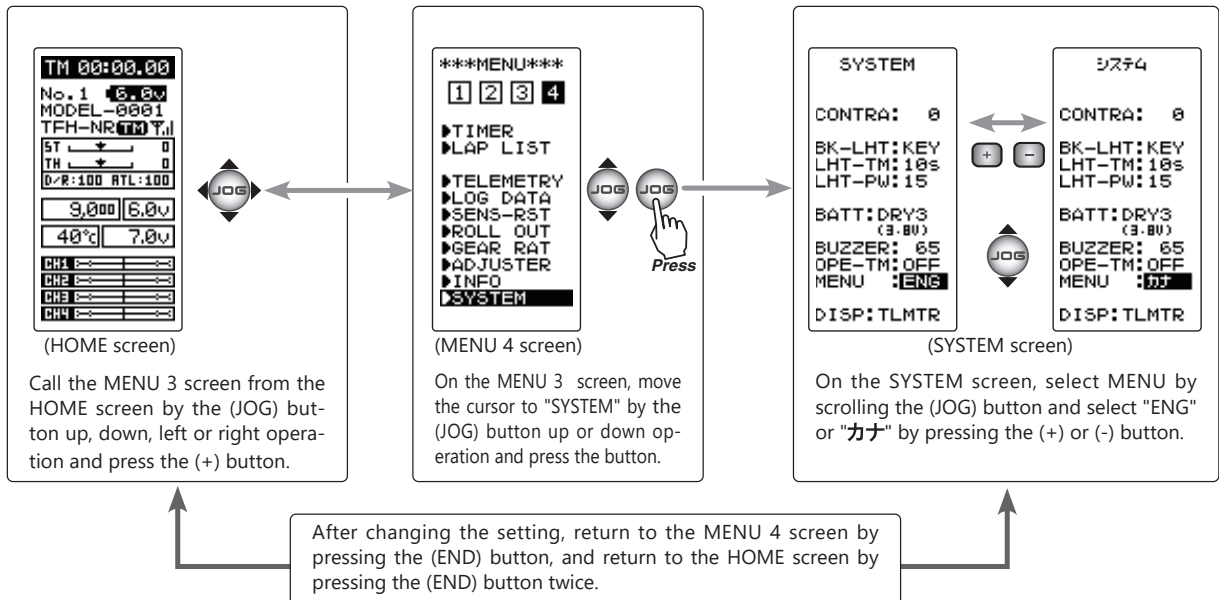



# Function List

Function List		
Function Abbreviation	Description Of Function	Page
<b>RECEIVER</b>	Receiver system selection, linking with receiver and SR mode Channel setting.	<a href="#">29</a>
<b>SYSTEM</b>	LCD contrast, backlight, Battery type, buzzer, power off reminder alarm, Basic menu character display, HOME screen display mode setting.	<a href="#">42</a>
<b>REVERSE</b>	Servo operation reversing.	<a href="#">46</a>
<b>SUBTRIM</b>	Servo center position fine adjustment.	<a href="#">47</a>
<b>END POINT</b>	End point adjustment.	<a href="#">48</a>
<b>EXP</b>	Steering curve adjustment, Throttle curve adjustment.	<a href="#">51</a>
<b>SPEED</b>	Steering servo delay, Throttle servo delay.	<a href="#">54</a>
<b>TH ACCEL</b>	Reduces the "lag time" of the throttle from the neutral position.	<a href="#">57</a>
<b>TH A.B.S</b>	Pumping brake.	<a href="#">59</a>
<b>TH MODE</b>	Throttle servo neutral position, Idle-Up, Neutral brake, Engine cut	<a href="#">63</a>
<b>TRACTION</b>	Function to make traction progress by intermittently moving the throttle	<a href="#">67</a>
<b>START</b>	Throttle preset at start function	<a href="#">70</a>
<b>D/R ATL</b>	Steering angle adjustment while running/ Brake side adjustment.	<a href="#">72</a>
<b>CH3/CH4</b>	Channel 3&4 servos operation position set and check.	<a href="#">73</a>
<b>MDL SELE</b>	Model memory call.	<a href="#">74</a>
<b>MDL NAME</b>	Model memory name set and modify, user name se and modify.	<a href="#">75</a>
<b>MDL COPY</b>	Model memory copy	<a href="#">76</a>
<b>MDL RES</b>	Model memory reset.	<a href="#">79</a>
<b>MDL TRANS</b>	Data copy from the T4PM to another T4PM.	<a href="#">80</a>
<b>MDL DELE</b>	The T4PM model memory data to another T4PM	<a href="#">82</a>
<b>FAIL SAFE</b>	Fail-safe, battery fail-safe	<a href="#">83</a>
<b>S.BUS SX</b>	Futaba S.BUS/S.BUS2 servo parameter setup.	<a href="#">85</a>
<b>MC LINK</b>	MC851C, 602C, 402CR, 950CR, 940CR, 960CR parameters setting function.	<a href="#">91</a>
<b>GYRO LINK</b>	Futaba gyeo parameter setup (GYD550)	<a href="#">100</a>
<b>TRIM DIAL</b>	Selection of the function to be performed by digital trim (DT1-DT5) dial (DL1).	<a href="#">104</a>
<b>SWITCH</b>	Selection of the function to be performed by push switch (SW1, SW2).	<a href="#">106</a>
<b>STR MIX</b>	Uses 2 servos to individually control the left and right steering.	<a href="#">108</a>
<b>BRAKE MIX</b>	Front and rear independent brake control for 1/5 gas power car, etc.	<a href="#">110</a>
<b>GYRO MIX</b>	The sensitivity of Futaba car rate gyros can be adjusted.	<a href="#">112</a>
<b>4WS</b>	4WS mixing.	<a href="#">114</a>
<b>DUAL ESC</b>	Front and rear ESCs mixing.	<a href="#">116</a>
<b>CPS MIX</b>	The CPS-1 of Futaba LED controller can be adjusted.	<a href="#">118</a>
<b>TANK MIX</b>	This function is intended for vehicles such as tanks	<a href="#">120</a>
<b>PROG MIX</b>	Programmable mixing between arbitrary channels.	<a href="#">122</a>
<b>TIMER</b>	Up, down, or lap timer.	<a href="#">124</a>
<b>LAP LIST</b>	Lap timer data (lap time, total time) check.	<a href="#">130</a>
<b>TELEMETRY</b>	Displays the status during operation of each sensor unit and records the status in a data log.	<a href="#">131</a>
<b>LOG</b>	Log Setting, Start/ Stop	<a href="#">138</a>
<b>SENS-RST</b>	Resets the sensor slot number	<a href="#">141</a>
<b>ROLL OUT</b>	For pan cars roll out chart	<a href="#">142</a>
<b>GERA RAT</b>	Gear ratio calculation function.	<a href="#">143</a>
<b>ADJUSTR</b>	Steering wheel and throttle trigger correction.	<a href="#">144</a>
<b>INFO</b>	Display version of T4PM program, ID information.	<a href="#">146</a>
<b>UPDATE</b>	T4PM program update.	<a href="#">147</a>



## System Functions "SYSTEM"

The graphic liquid crystal screen display mode, buzzer sound and menu character mode, etc. can be set.

- "CONTRA" -- Liquid crystal screen contrast adjustment (20 steps)
- "BK-LHT" --- Liquid crystal screen backlighting display mode setup (OFF, ON at button operation, normally ON)
- "LHT-TM" -- Setting of ON time (1~30 secs) when [ON at button operation] was selected above.
- "BATT" ----- Battery type setting (LiFe2, DRY3, CSTM)  
The T4PM PULS can use an optional rechargeable battery. However, the battery alarm setting is different from that of the dry cell battery (alkaline battery recommended). Therefore, always set the battery type to match the power source used.  
If used with the incorrect setting, the normal low battery alarm function will not work and the system may stop before a battery alarm is generated. The usage time may also become extremely short.
- "BUZZER" -- Buzzer sound tone adjustment (OFF, 100 steps)
- "OPE-TM" -- The power off reminder alarm setting (OFF, 10 m)
- "MENU" ---- Item which displays the basic menu screen in katakana characters for Japanese use.
- "DISP" ----- HOME screen display mode setting (Telemetry data, Timer, Users name)

Display "SYSTEM" screen using the following method:

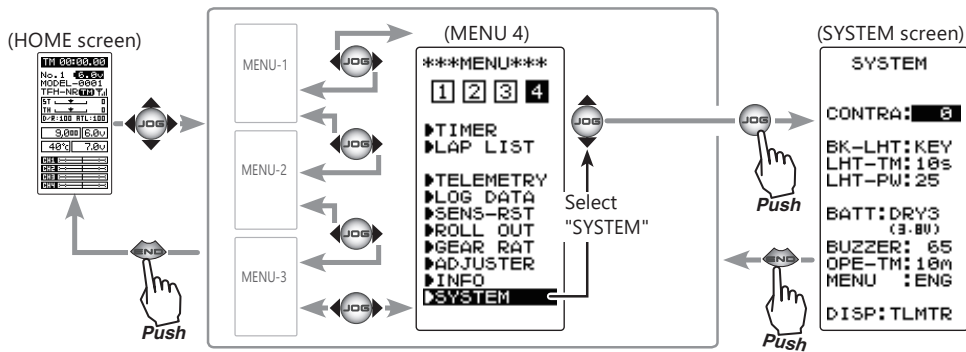

SYSTEM	
CONTRA:	8
BK-LHT:	KEY
LHT-TM:	10s
LHT-PW:	25
BATT:	DRY3
	(3.BU)
BUZZER:	65
OPE-TM:	10m
MENU:	ENG
DISP:	TLMTR

<b>Setup items</b>	
CONTRA:	Contrast
BK-LHT:	Backlighting mode
LHT-TM:	Backlighting time
LHT-PW:	Backlighting brightness
BATT:	Battery type
BUZZER:	Buzzer tone
OPE-TM:	Power off forgotten alarm
MENU:	Menu screen character
DISP:	HOME screen display mode

# 1 (Setting of each item)

## (Adjusting the liquid crystal contrast)

Select the setting item "CONTRA" by moving the (JOG) button up or down, and use the (+) and (-) buttons to adjust the screen contrast.

- Adjust to an easy-to-see contrast.

When finished with the setting, return to the MENU screen by pressing the (END) button.



### Adjustment buttons

- Use the (+) and (-) buttons to make adjustments.
- Press the (+) and (-) buttons simultaneously (approx. 1 sec) to return to the initial value.

**Contrast (CONTRA)**  
-10~0~+10  
Initial value: 0

## (Setting the liquid crystal backlighting mode)

Select the setting item "BK-LHT" by moving the (JOG) button up or down, and select the mode by pressing the (+) or (-) button.

"KEY": Fixed time backlighting ON after button operated.

"ALL": Backlighting always ON.

"OFF": Backlighting OFF.

When finished with the setting, return to the MENU screen by pressing the (END) button.

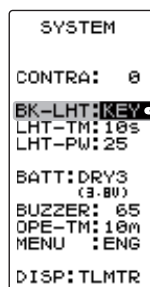

**Backlight mode (BK-LHT)**  
KEY, ALL, OFF

## (Setting liquid crystal backlighting time)

Select the setting item "LHT-TM" by moving the (JOG) button up or down, and use the (+) and (-) buttons to set the ON time.

- When "KEY" is set at the preceding item, this ON time becomes effective.

When finished with the setting, return to the MENU screen by pressing the (END) button.

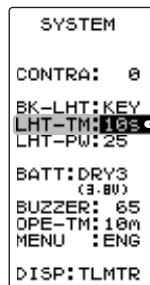

**Backlighting time (LHT-TM)**  
1~30  
Initial value: 10

## (Setting liquid crystal backlighting brightness)

Select the setting item "LHT-PW" by moving the (JOG) button up or down, and use the (+) and (-) buttons to set the ON time.

-If too bright, the battery will be consumed.

When finished with the setting, return to the MENU screen by pressing the (END) button.

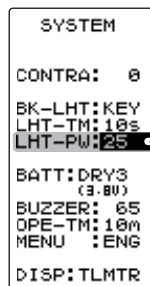

**Backlighting brightness (LHT-PW)**  
1~30  
Initial value: 15



## (Setting the battery type)

Select the setting item "BATT" by moving the (JOG) button up or down, and select the mode by pressing the (+) or (-) button.

**Note:** If the battery type is changed to the wrong setting, the low battery alarm will be generated immediately after the change and operation will become impossible.

If the low battery alarm is generated, please return the setting to just before, or turn off the power and replace the battery with a fully charged battery or a new dry cell battery. Then, reset the battery type.

**Note:** If used with the incorrect setting, a normal low battery alarm will not be generated and the system may stop before the battery alarm is generated. The usage time may also become extremely short.

"LiFe2": Futaba LiFe type battery (FT2F1100B / 1700BV2 / 2100BV2).

"DRY4": Dry cell battery (alkaline battery recommended) 4 batteries.

"CSTM": Third party battery is used.

This function is selected by exception when a third party battery is used. In this case, the low battery alarm voltage is set at the user's own risk. When "CSTM" is selected, the low battery alarm voltage displayed below can be adjusted. By operating the (JOG) button, move the cursor to the voltage display, and set the voltage by using the (+) or (-) button.

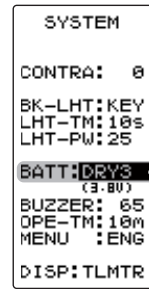

Battery Type (BATT)  
LiFe2, DRY4, CSTM

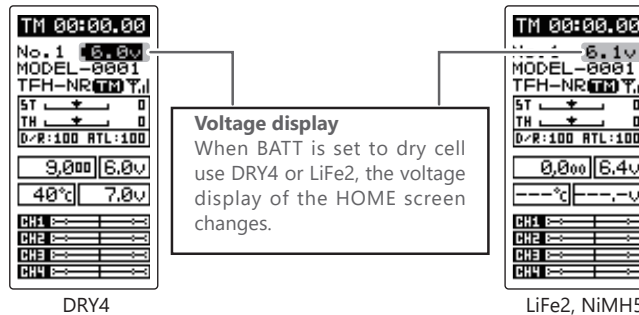

When finished with the setting, return to the MENU screen by pressing the (END) button.

## (Adjusting the buzzer tone)

Select the setting item "BUZZER" by moving the (JOG) button up or down, and use the (+) and (-) buttons to adjust the tone.

- Decide by referring to the tone at adjustment.

When finished with the setting, return to the MENU screen by pressing the (END) button.

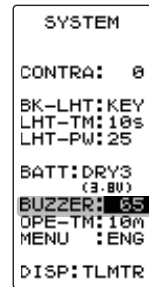

Buzzer tone (BUZZER)  
OFF, 1~100  
Initial value: 65

## (Changing the power off reminder alarm setting)

Select the setting item "OPE-TM" by moving the (JOG) button up or down, and use the (+) and (-) buttons to select the power off forgotten alarm mode.

"10m": If an operation is not performed within 10 minutes while the power is on, an audible alarm sounds.

"OFF": Power off forgotten alarm setting OFF.

When finished with the setting, return to the MENU screen by pressing the (END) button.

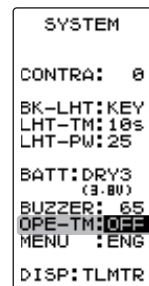

The power off forgotten alarm (OPE-TM)  
10m, OFF



### (Changing the menu character display)

Select the setting item "MENU" by moving the (JOG) button up or down, and set the basic menu character display with the (+) or (-) button ([See page 40](#)).

"ENG": Basic menu displayed in Alphabetic character.  
 "カナ": Basic menu displayed in katakana character.

When finished with the setting, return to the MENU screen by pressing the (END) button.

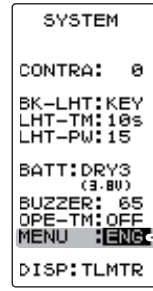

Menu character (MENU)  
ENG, カナ

### (Changing the HOME screen display mode)

Select the setting item "DISP" by moving the (JOG) button up or down, and set the HOME screen display mode with the (+) or (-) button.

"RXVOL": Telemetry data is displayed. (RX page 1)  
 "CURR": Telemetry data is displayed. (RX page 2)  
 "MC970": The MC970CR Telemetry data is displayed.  
 "TIMER": Timer is displayed.  
 "USER": User name is displayed.  
 \*MC970CR/MC971 is available only in the Japanese market.  
 (As of August 2022)

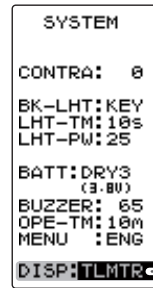

The T-FHSS system only telemetry data "RXVOL", "CURR" and "MC970" can be selected.

HOME screen mode (DISP)  
RXVOL, CURR, MC970  
TIMER, USER

When finished with the setting, return to the MENU screen by pressing the (END) button.

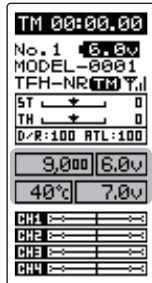

RXVOL

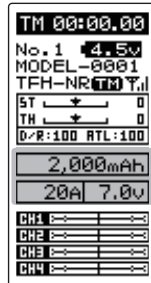

CURR

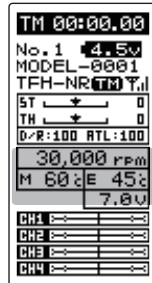

MC970

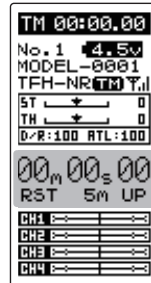

TIMER

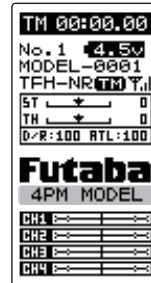

USER



This function reverses the direction of operation of the servos related to transmitter steering, throttle, and channels 3/4 operation.

However, when the position set by trim or subtrim shifts from the center, the center becomes the opposite side.

Display to "REVERSE" screen using the following method:

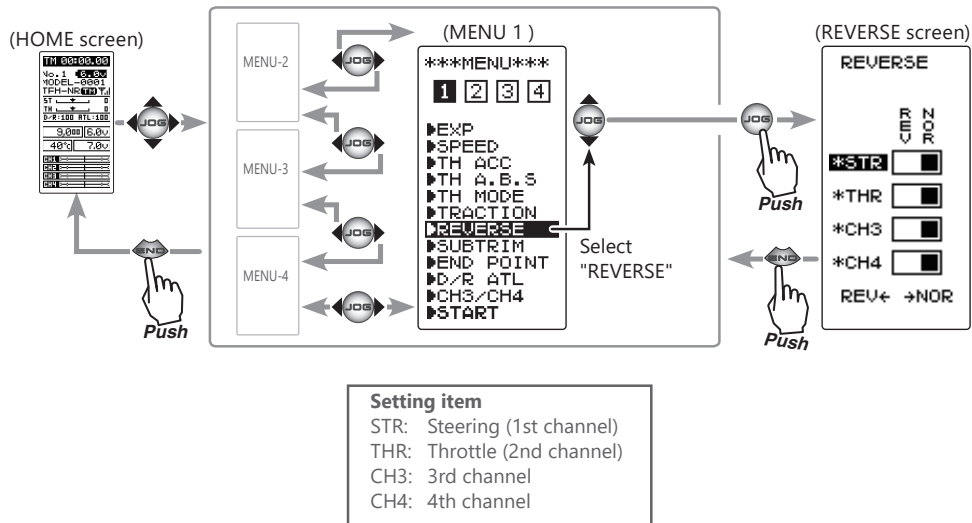

## Servo reverse function setting

(Preparation)

- Select the channel to be set by moving the (JOG) button up or down.

### 1 (Servo reverse setting)

Use the (+) or (-) button to reverse the servo operation direction.

NOR/REV can also be set by moving the (JOG) button left or right.

(Each channel can be set similar.)

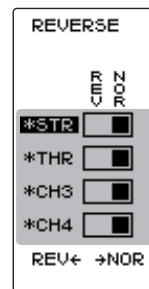

Move the cursor to "STR, THR, CH3 or CH4" with the (JOG) button.

#### Select button

- Select with the (+) or (-) buttons.

Or use the jog dial left or right to set the normal, reverse operations.

### 2 When finished with the setting, return to the MENU screen by pressing the (END) button.

# Subtrim "SUBTRIM"

(All channel)

Use this function to adjust the neutral position of the steering, throttle, channel 3 and channel 4 servos.

\*Subtrim adjusts the entire range of the servo in the set direction.

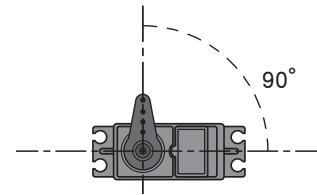
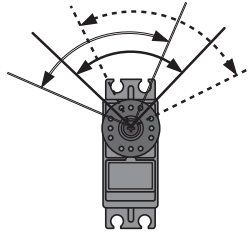

Use to adjust the neutral position

Display to "SUBTRIM" screen using the following method:

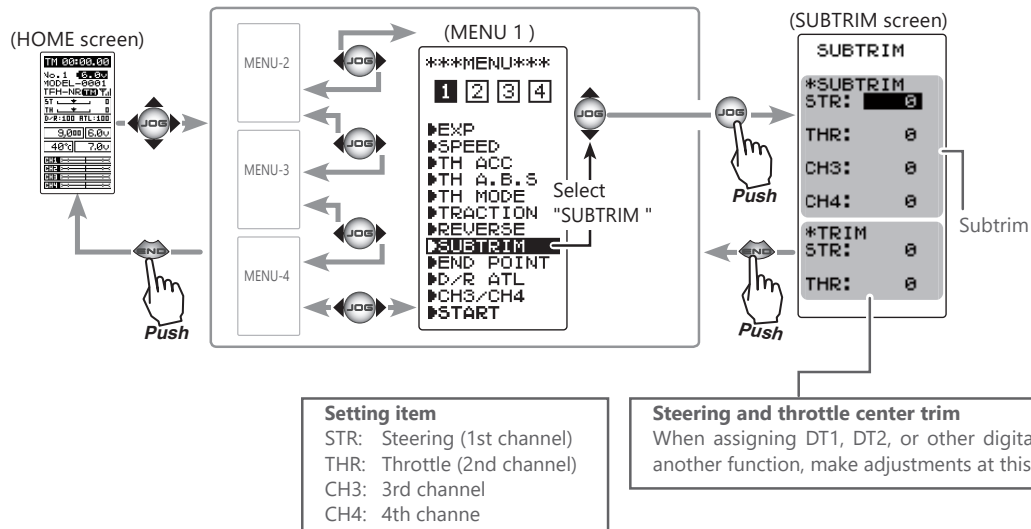

## Subtrim adjustment

(Preparation)

- Set the steering and throttle digital trims to the neutral "0" position. Set CH3 and CH4 to the center "0" position.

### 1 (Subtrim adjustment)

Use the (+) or (-) button to adjust the center.  
 (Each channel can be set similar.)

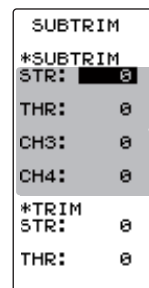

Move the cursor to "STR, THR, CH3 and CH4" with the (JOG) button.

#### Adjustment buttons

- Use the (+) and (-) buttons to make adjustments.
- Return to the initial value by pressing the (+) and (-) buttons simultaneously (approx. 1 sec).

#### Subtrim Values

STR: L100~R100  
 THR: B100~F100  
 CH3: -100~+100  
 CH4: -100~+100  
 Initial value: 0

#### Trim Values

STR: L100~R100  
 THR: B100~F100  
 Initial value : 0

### 2 When finished with the setting, return to the MENU screen by pressing the (END) button.

## End Point Adjuster "END POINT"

(All channel)

Use this when performing left and right end point adjustments, throttle high side/brake side operation amount adjustment, or channel 3 and channel 4 servo up side/down side operation amount adjustment during linkage.

- Correct the maximum steering angle for left and right steering angles when there is a difference in the turning radius due to the characteristics of the vehicle.

### Maximum steering angle

The "END POINT" function basically determines the maximum steering angle of each channel.

The functions shown below may have been adjusted or the operating range set by "END POINT" function may be exceeded. Check the linkage each time the following functions are adjusted.

- Sub trim (all channels) ..... [page 47](#)
- Throttle acceleration (throttle) ..... [page 57](#)
- Idle up (throttle) ..... [page 64](#)
- Throttle off, Engine Cut (throttle) ..... [page 66](#)
- Program mixing slave side (all channels) .... [page 122](#)

### ATL trim

ATL trim allows adjustment of the brake side operation amount during operation.

Therefore, when the operating angle is adjusted with throttle END POINT, ATL trim must also be taken into account.

### Warning

- ❗ Operate each servo over its full stroke and be sure the linkage does not bind or is not loose.

The continuous application of unreasonable force to a servo may cause damage and excessive battery drain.

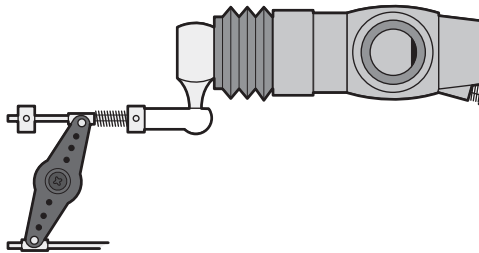

Adjust the throttle servo so that unreasonable force is not applied when the engine carburetor is fully open, fully closed, and the brakes are applied fully.

If the brakes overheat while running, their ability to function properly decreases. Before running, adjust the suitable maximum servo travel so that unreasonable force is not applied even when the servo travel is increased while running.

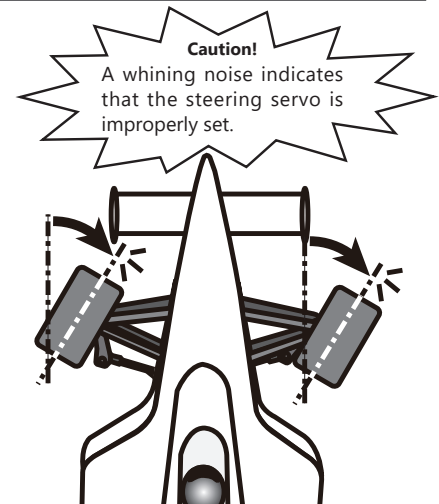

Decide the END POINT value at the contact point.

Adjust the steering servo so that unreasonable force is not applied to the servo by the chassis at maximum servo travel.





Display to "END POINT" screen using the following method:

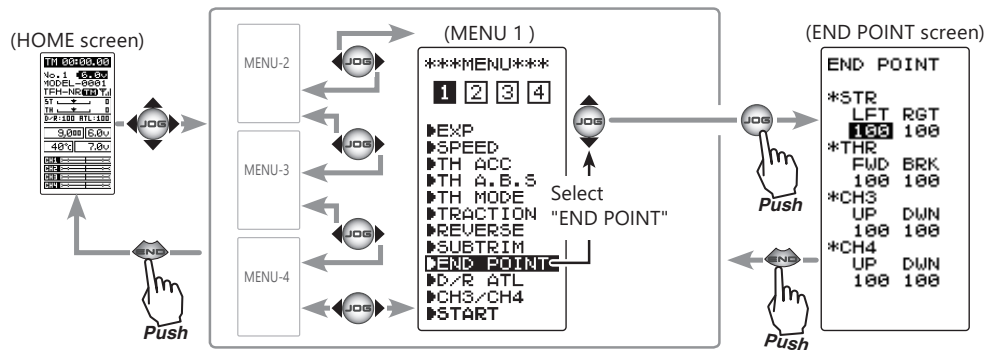

#### Setting item selection

##### (Steering and Throttle direction)

- The direction (STR LFT and STR RGT) linked with the steering wheel is switched.
- The direction (THR FWD and THR BRK) linked with the throttle trigger is switched.

##### Setting item (channel and direction)

STR LFT:	Steering (left side)
STR RGT:	Steering (right side)
THR FWD:	Throttle (forward side)
THR BRK:	Throttle (brake side)
CH3/CH4 UP:	3rd or 4th channel (up side)
CH3/CH4 DWN:	3rd or 4th channel (down side)

### Steering (END POINT) adjustment

(Preparation)

- Before setup of the steering end point adjustment (END POINT), set the steering D/R trim (initial setup: DT4) to the maximum steering angle position 100%.
- Use the (JOG) button to select the setting item "RGT" and make the following adjustments: and make the following adjustments: Or turn the steering wheel to select LFT or RGT.

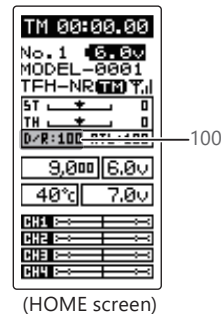

#### 1 Steering (left side) adjustment

Turn the steering wheel fully to the left and use the (+) or (-) buttons to adjust the steering angle.

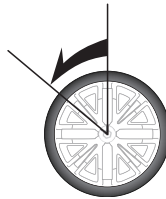

#### 2 Steering (right side) adjustment

Turn the steering wheel fully to the right and use the (+) or (-) buttons to adjust the steering angle.

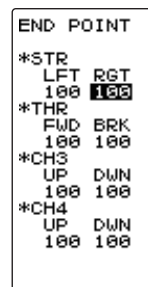
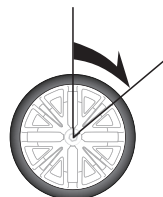

#### Adjustment buttons

- Use the (+) and (-) buttons to make adjustments.
- Return to the initial value by pressing the (+) and (-) buttons simultaneously (approx. 1 sec).

#### Steering END POINT

STR LFT: 0~120  
STR RGT: 0~120  
Initial value: 100

#### 3 When finished with the setting, return to the MENU screen by pressing the (END) button.

## Throttle (END POINT) adjustment

(Preparation)

- Before setting the throttle end point adjustment (END POINT), set the throttle ATL trim (initial setup: DT5) to the maximum throttle angle position 100%.
- Select the setting item "FWD" by moving up or down on the (JOG) button and make the following adjustments: Or move the throttle trigger fore or aft to select FWD or REV.

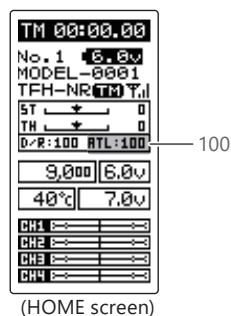

### 1 Throttle (forward side) adjustment

Pull the throttle trigger fully to the high side and use the (+) or (-) buttons to adjust the throttle angle. However, when using an electronic motor speed controller (ESC), set to 100%.



### 2 Throttle (brake side/reverse side) adjustment

Move the throttle trigger fully to the brake side and use the (+) or (-) buttons to adjust the throttle angle. However, when using an electronic motor speed controller (ESC), set to 100%.

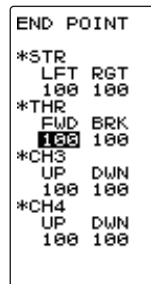

#### Adjustment buttons

- Use the (+) and (-) buttons to make adjustments.
- Return to the initial value by pressing the (+) and (-) buttons simultaneously (approx. 1 sec).

#### Throttle END POINT

THR FWD: 0~120  
THR BRK: 0~120  
Initial value: 100

### 3 When finished with the setting, return to the MENU screen by pressing the (END) button.

## 3rd & 4th channel servo (END POINT) adjustment

### 1 3rd/4th channel servo (up side) adjustment

Select the setting item "CH3 or CH4 UP" by moving the (JOG) button up or down. Set the 3rd or 4th channel dial fully to the up side (+ side) and use the (+) or (-) buttons to adjust the servo angle.

### 2 3rd/4th channel servo (down side) adjustment

Select the setting item "CH3 or CH4 DWN" by moving the (JOG) button up or down. Set the 3rd or 4th channel dial fully to the up side (- side) and use the (+) or (-) buttons to adjust the servo angle.

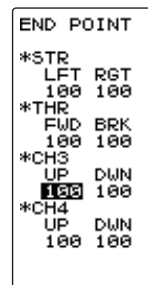

#### Adjustment buttons

- Use the (+) and (-) buttons to make adjustments.
- Return to the initial value by pressing the (+) and (-) buttons simultaneously (approx. 1 sec).

#### 3rd & 4th channel END POINT

CH3/CH4 UP: 0~120  
CH3/CH4 DWN: 0~120  
Initial value : 100

### 3 When finished with the setting, return to the MENU screen by pressing the (END) button.



# Exponential Adjustment "EXP"

(Steering/ Throttle system)

This function is used to change the sensitivity of the servo around the neutral position.

Display to "EXP" screen using the following method:

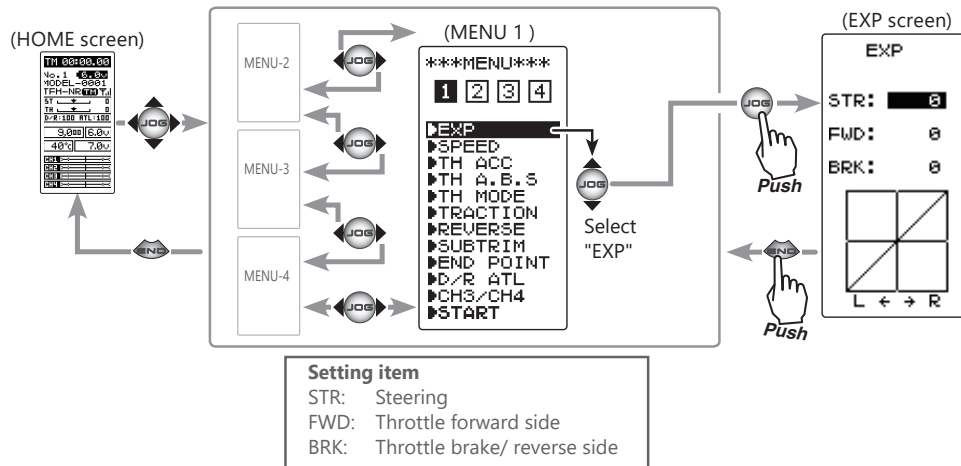

## STR (Steering EXP)

This function is used to change the sensitivity of the steering servo and around the neutral position. It has no effect on the maximum servo travel.

### Racers Tip

When the setting is not determined, or the characteristics of the model are unknown, start with 0%. (When EXP is set to 0%, servo movement is linear.)

## Steering EXP adjustment

(Preparation)

- On the EXP screen, select the setting item "STR" by moving the (JOG) button up or down.

- 1 When you want to quicker steering operation, use the (+) button to adjust the + side. When you want to make steering operation milder, use the (-) button to adjust the - side.

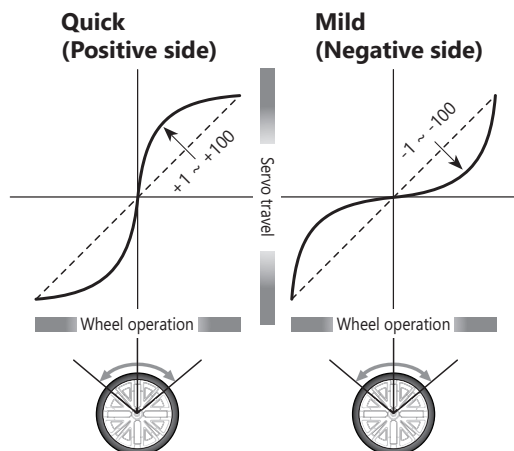

**Adjustment range**  
-100~0~+100

### Adjustment buttons

- Use the (+) and (-) buttons to make adjustments.
- Return to the initial value by pressing the (+) and (-) buttons simultaneously (approx. 1 sec).

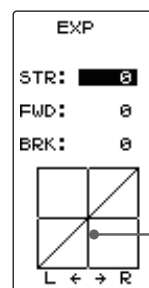

Vertical cursor moves in step with steering wheel operation.

- 2 When finished with the setting, return to the MENU screen by pressing the (END) button.

## FWD (Throttle Forward Side EXP) / BRK (Throttle Brake Side EXP)

This function makes the throttle forward side and brake side direction servo operation quicker or milder. It has no effect on the servo maximum operation amount.

### Advice

When the course conditions are good and the surface has good grip, set each curve to the + side (quick side). When the road surface is slippery and the drive wheels do not grip it, set each curve to the - minus (mild) side.

### Throttle forward side EXP adjustment

(Preparation)

- On the EXP screen make the following adjustments:

- 1 Select the setting item "FWD" by moving the (JOG) button up or down. Use the (+) button to adjust for a faster throttle response or use the (-) button for a slower or milder throttle response.

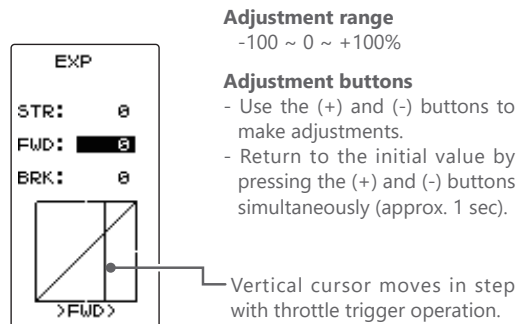
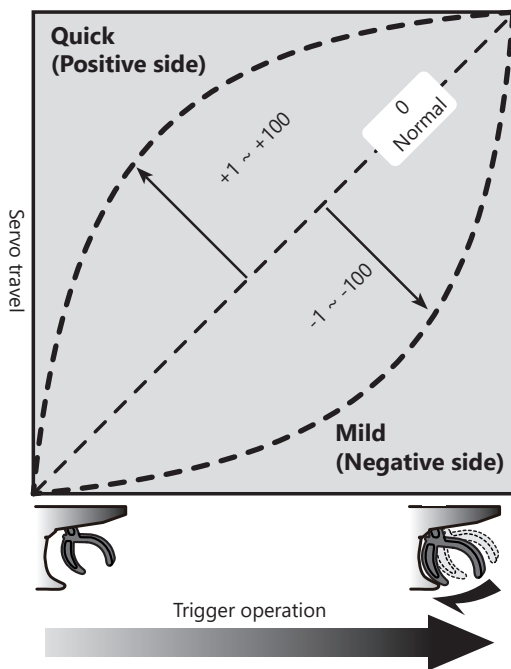

- 2 When finished with the setting, return to the MENU screen by pressing the (END) button.



## Throttle brake side EXP adjustment

(Preparation)

- On the EXP screen make the following adjustments:

- 1 Select the setting item "BRK" by moving the (JOG) button up or down. Use the (+) button to adjust for a faster brake response or use the (-) button for a slower or milder brake response.

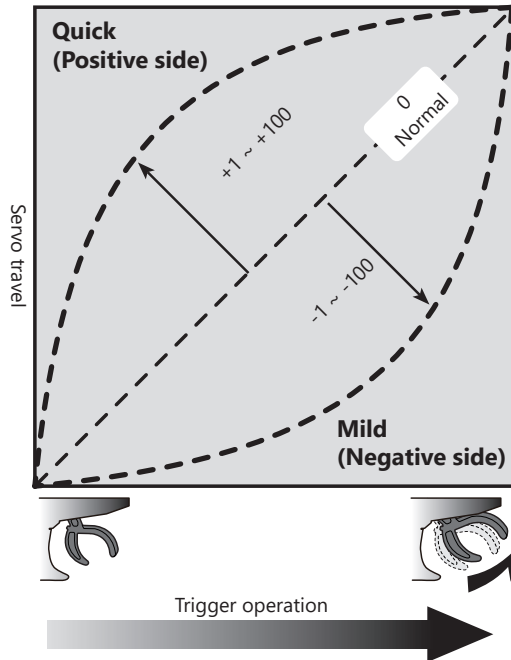

### Adjustment range

-100 ~ 0 ~ +100%

### Adjustment buttons

- Use the (+) and (-) buttons to make adjustments.
- Return to the initial value by pressing the (+) and (-) buttons simultaneously (approx. 1 sec).

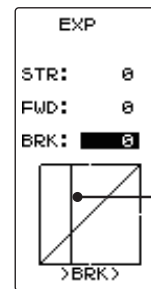

Vertical cursor moves in step with throttle trigger operation.

- 2 When finished with the setting, return to the MENU screen by pressing the (END) button.

## Dial / Trim Setting

The steering and throttle EXP adjustment (RATE) can be controlled with digital dial or digital trim. With the function select trim dial function ([See page 104](#)).

This function limits the maximum speed of the steering servo (Delay function).

Display to "SPEED" screen using the following method:

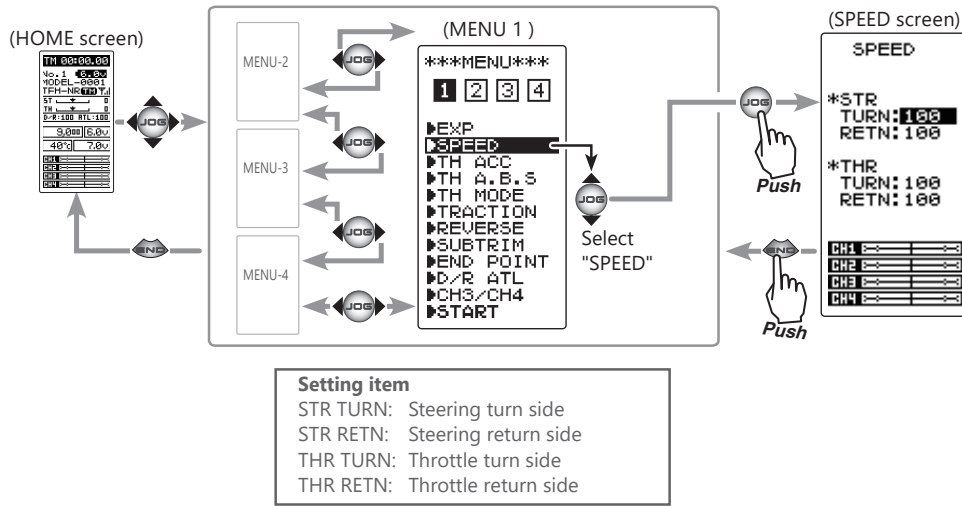

## STR (Steering Speed)

Quick steering operation will cause momentary understeering, loss of speed, or spinning. This function is effective in such cases.

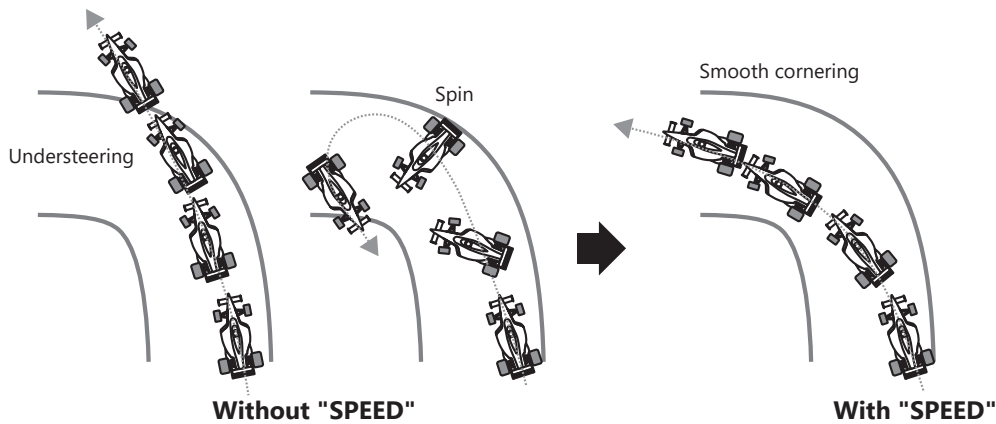

### Operation

- The steering speed when the steering wheel is operated (TURN direction) and returned (RETN direction) can be independently set.
- If the steering wheel is turned slower than the set speed, the steering servo is not affected.

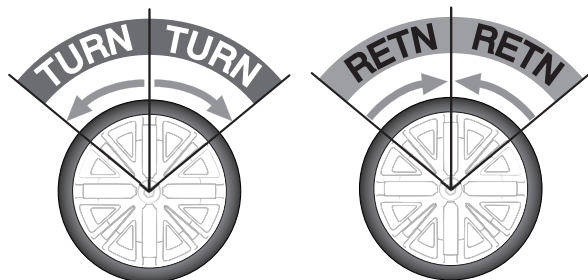

## Steering Speed adjustment

(Preparation)

- On the SPEED screen make the following adjustments:

### 1 "TURN" direction adjustment

On the SPEED screen, select the setting item STR "TURN" by moving the (JOG) button up or down. Use the (+) or (-) buttons to adjust the delay amount.

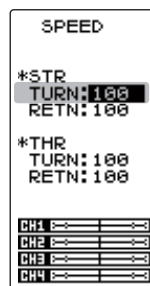
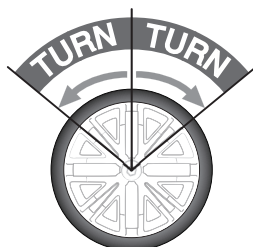

#### Adjustment range

1~100% (each direction)  
At 100%, there is no delay.

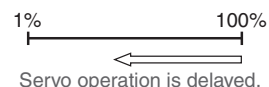

#### Adjustment buttons

- Use the (+) and (-) buttons to make adjustments.
- Return to the initial value by pressing the (+) and (-) buttons simultaneously (approx. 1 sec).

### 2 "RETN" direction adjustment

Select the setting item STR "RETN" by moving the (JOG) button up or down. Use the (+) or (-) buttons to adjust the delay amount.

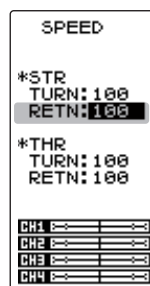
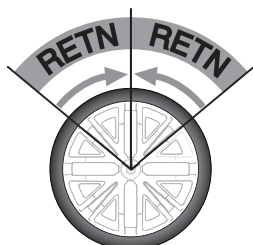

#### Adjustment range

1~100% (each direction)  
At 100%, there is no delay.

#### Adjustment buttons

- Use the (+) and (-) buttons to make adjustments.
- Return to the initial value by pressing the (+) and (-) buttons simultaneously (approx. 1 sec).

### 3 When finished with the setting, return to the MENU screen by pressing the (END) button.

#### Setting example (Steering servo: BLS451 / BLS351) . . . (Setting criteria)

- On road TURN side: Approx. 50~80% RETURN side: Approx. 60~100%
- Off road TURN side: Approx. 70~100% RETURN side: Approx. 80~100%

#### Dial / Trim Setting

The steering speed adjustment "TURN" and "RETN" can be controlled with digital dial or digital trim. With the function select trim dial function ([See page 104](#)).



# THR (Throttle Speed)

Sudden throttle trigger operation on a slippery road causes the wheels to spin and the vehicle cannot accelerate smoothly. Setting the throttle speed function reduces wasteful battery consumption while at the same time permitting smooth, enjoyable operation.



With "SPEED": Quick start without skidding



Without "SPEED": Slow start due to skidding

## Operation

- Throttle servo (ESC) operation is delayed so that the drive wheels will not spin even if the throttle trigger is operated more than necessary.

This delay function is not performed when the throttle trigger is returned and at brake operation.

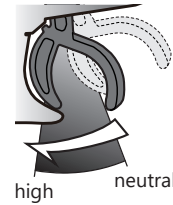

## Throttle Speed adjustment

(Preparation)

- On the SPEED screen make the following adjustments:

### 1 "TURN" direction adjustment

On the SPEED screen, select the setting item THR "TURN" by moving the (JOG) button up or down. Use the (+) or (-) buttons to adjust the delay amount.

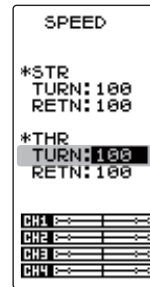

#### Adjustment range

1~100%  
At 100%, there is no delay.

#### Adjustment buttons

- Use the (+) and (-) buttons to make adjustments.
- Return to the initial value by pressing the (+) and (-) buttons simultaneously (approx. 1 sec).

### 2 "RETN" direction adjustment

Select the setting item THR "RETN" by moving the (JOG) button up or down. Use the (+) or (-) buttons to adjust the delay amount.

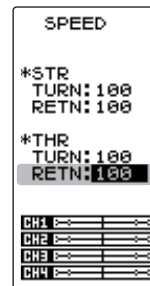

#### Adjustment range

1~100%  
At 100%, there is no delay.

#### Adjustment buttons

- Use the (+) and (-) buttons to make adjustments.
- Return to the initial value by pressing the (+) and (-) buttons simultaneously (approx. 1 sec).

## Warning

- ⚠ Setting the speed function in the return direction slows the deceleration of the car body, so please be careful to set it carefully.

### 3 When finished with the setting, return to the MENU screen by pressing the (END) button.

## Dial / Trim Setting

The throttle speed adjustment can be controlled with digital dial or digital trim. With the function select trim dial function ([See page 104](#)).



# Throttle Acceleration "TH ACC"

(Throttle system)

The servo will jump to the input position at its maximum possible speed. Unlike exponential, which adjusts the whole throttle movement into a curve, throttle acceleration simply "jumps" away from neutral and then leaves the remaining response linear.

## Operation

- Operation near the throttle trigger neutral position becomes a sharp rise.
- The forward and brake sides can be set separately.

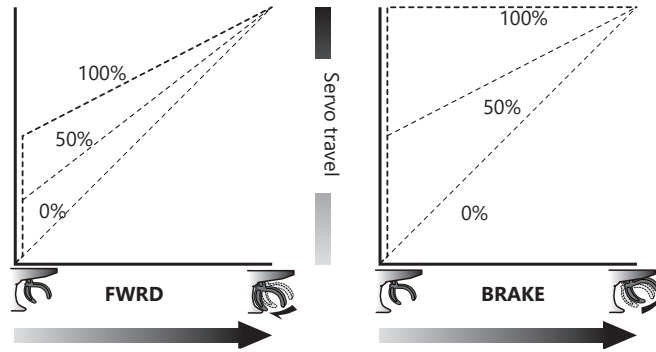

## Set value

The standard value (100% point) of this setup affects the operation amount set by throttle END POINT function.

## Convenient usage method

For nitro powered cars, the linkage must have a clearance because one servo controls the engine carburetor and brake. Thus, there is a noticeable time delay at both the forward and brake sides. Sharp response comparable to that of electric motor cars is obtained by reducing this clearance at the transmitter side.

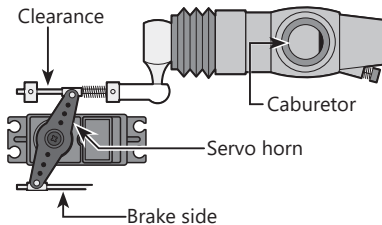

Display to "TH ACC" screen using the following method:

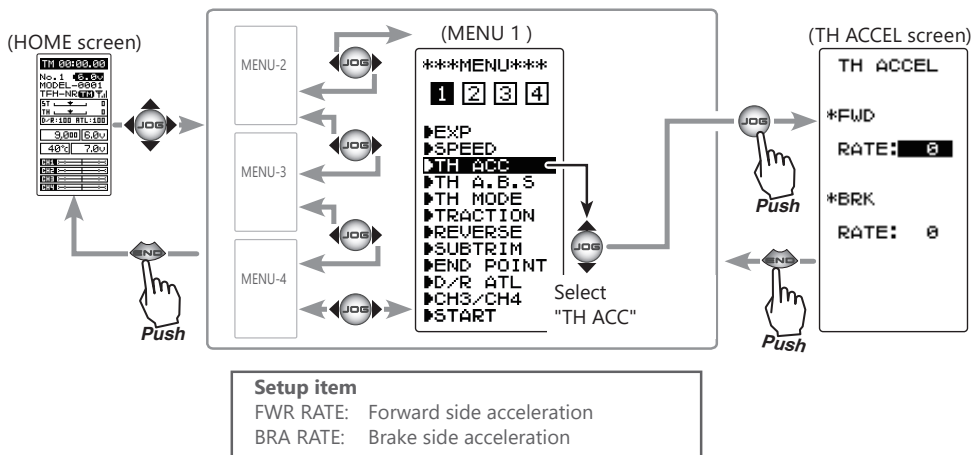

## Throttle acceleration adjustment

(Preparation)

- On the TH ACCEL screen make the following adjustments:

- 1** (Forward acceleration amount adjustment)  
Select the setting item FWD "RATE" by moving the (JOG) button up or down. Use the (+) and (-) buttons to adjust the acceleration amount.

"0": No acceleration.

"100": Maximum acceleration (Approximately 1/2 of the forward side throttle angle).

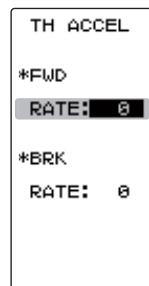

**Forward acceleration amount (FWD)**  
0~100  
Initial value: 0

### Adjustment buttons

- Use the (+) and (-) buttons to make adjustments.
- Return to the initial value by pressing the (+) and (-) buttons simultaneously (approx. 1 sec).

- 2** (Brake side acceleration amount adjustment)  
Select the setting item BRK "RATE" by moving the (JOG) button up or down. Use the (+) and (-) buttons to adjust the acceleration amount.

"0": No acceleration.

"100": Maximum acceleration (Brake side maximum throttle angle).

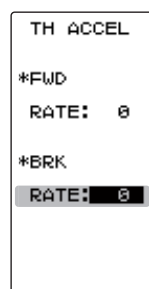

**Brake side acceleration amount (BRK)**  
0~100  
Initial value: 0

### Adjustment buttons

- Use the (+) and (-) buttons to make adjustments.
- Return to the initial value by pressing the (+) and (-) buttons simultaneously (approx. 1 sec).

If the ["Brake Mixing Function" \(page 110\)](#) is being set, the auxiliary channel brake side acceleration will become adjustable.

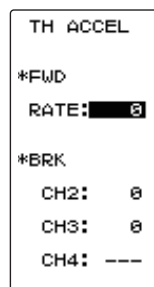

Brake Mix  
CH3---ACT

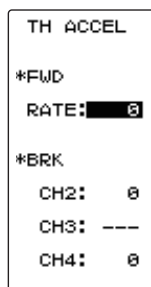

Brake Mix  
CH4---ACT

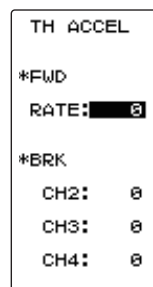

Brake Mix  
CH3/4---ACT

- 3** When finished with the setting, return to the MENU screen by pressing the (END) button.

## Dial / Trim Setting

The throttle acceleration adjustment amount (FWD), (BRK) can be controlled with digital dial or digital trim. With the function select trim dial function ([See page 104](#)).



# A.B.S. Function "TH A.B.S"

(Throttle system)

When the brakes are applied while cornering with a 4 Wheel Drive or other types of vehicle, understeer may occur. Understeer can be eliminated and corners can be smoothly cleared by using this function.

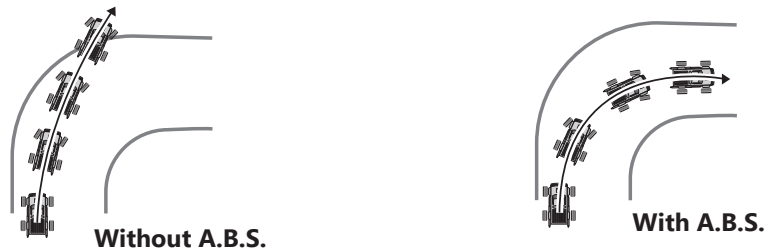

## Operation

- When the brakes are applied, the throttle servo will pulse intermittently. This will have the same effect as pumping the brakes in a full size car.
- The brake return amount, delay amount, pulse cycle, and brake duty can be adjusted.

## Operation display

During ABS operation, the LED blinks.

Display "TH A.B.S" screen using the following method:

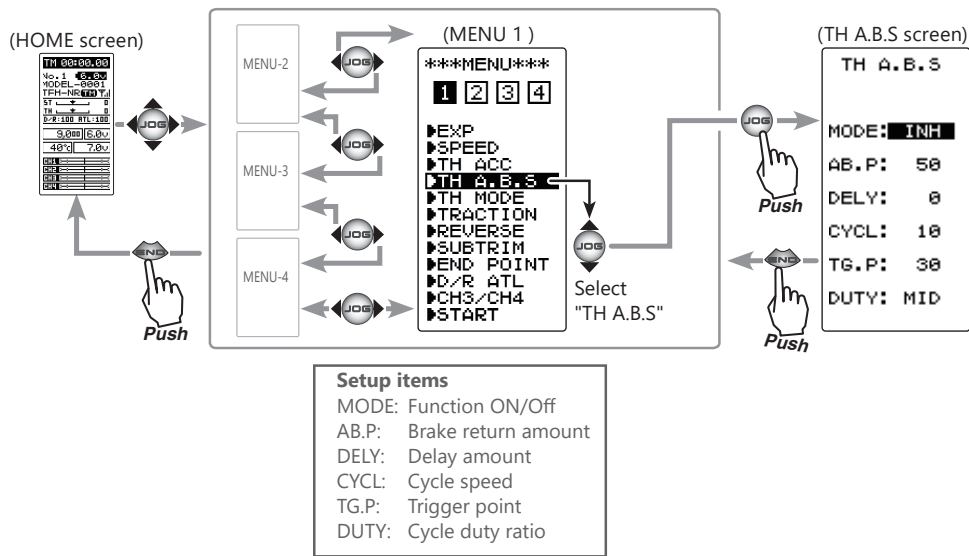

### - MODE: Function ON/OFF

ABS function ON/OFF setting. When using the ABS function, set to "ACT (ON)".

### - AB.P : Amount of brake return

Sets the rate at which the servo returns versus trigger operation for brake release. When set to 0%, the ABS function is not performed. When set to 50%, the servo returns 50% (1/2) of the trigger operation amount and when set to 100%, the servo returns to the neutral position.

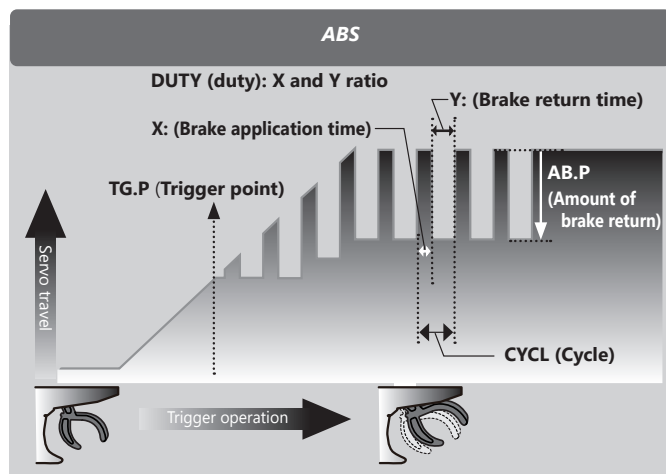

**- DELY : Delay**

Sets the delay from brake operation to ABS operation. When set to 0%, the ABS function is activated without any delay. At 50%, the ABS function is activated after a delay of approximately 1 second and at 100%, the ABS function is activated after a delay of approximately 2 seconds.

**- CYCL : Cycle speed**

Sets the pulse speed (cycle). The smaller the set value, the faster the pulse cycle.

**- TG.P : Trigger point**

Sets the trigger point at which the ABS function begins to operate at brake operation.

**- DUTY : Cycle duty ratio**

Sets the proportion of the time the brakes are applied and the time the brakes are released by pulse operation. The ratio can be set to HIGH, MID or LOW.

**A.B.S function adjustment**

**1** (Function ON/OFF)

Select the setting item "MODE" by moving the (JOG) button up or down. Set the function to the active state by pressing the (+) or (-) button.

- "INH (OFF)": Function OFF.
- "ACT (ON)": Function ON.
- "ACT (OFF)": Switch OFF when setting switches.

**Select button**

- Select with the (+) or (-) buttons.

**Function ON/OFF (MODE)**

INH (OFF), ACT (ON, OFF)

**2** (Brake return amount adjustment)

Select the setting item "AB.P" by moving the (JOG) button up or down. Use the (+) or (-) button to adjust the return amount.

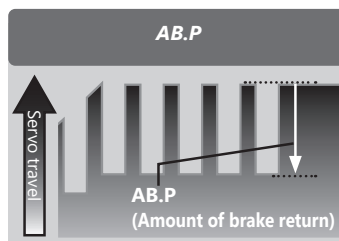

- "0": No return.
- "50": Return to the 50% position of the brake operation amount.
- "100": Return to the neutral position.

**Brake return amount (AB.P)**

0 ~ 50 ~ 100  
Initial value: 50

- Brake return amount (AB.P) is influenced by the "EXP" rate on the brake side.

**Adjustment buttons**

- Use the (+) and (-) buttons to make adjustments.  
- Return to the initial value by pressing the (+) and (-) buttons simultaneously (approx. 1 sec).

**3** (Delay amount setup)

Select the setting item "DELY" by moving the (JOG) button up or down. Use the (+) or (-) button to adjust the delay amount.

- "0": A.B.S. function performed without any delay.
- "50": A.B.S. function performed after an approximate 1 sec delay.
- "100": A.B.S. function performed after an approximate 2 secs delay.

**Delay amount (DELY)**

0 ~ 100  
Initial value: 0

**Adjustment buttons**

- Use the (+) and (-) buttons to make adjustments.  
- Return to the initial value by pressing the (+) and (-) buttons simultaneously (approx. 1 sec).



#### 4 (Cycle speed adjustment)

Select setting item "CYCL" by moving the (JOG) button up or down. Use the (+) or (-) button to adjust the pulse speed (cycle).

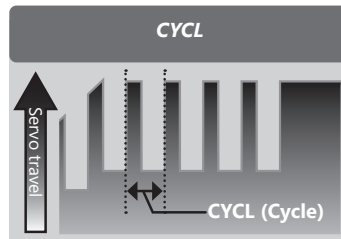

- The smaller the set value, the faster the pulse speed.

#### Cycle speed (CYCL)

1 ~ 30  
Initial value: 10

#### Adjustment buttons

- Use the (+) and (-) buttons to make adjustments.
- Return to the initial value by pressing the (+) and (-) buttons simultaneously (approx. 1 sec).

#### 5 (Trigger point setup)

Select setting item "TG.P" by moving the (JOG) button up or down. Use the (+) or (-) button to adjust the operating point.

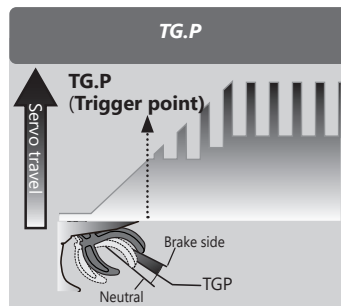

- Sets the throttle trigger position at which the A.B.S. function is performed. The number is the % display with the full brake position made 100.

#### Trigger point (TG.P)

10 ~ 100  
Initial value: 30

#### Adjustment buttons

- Use the (+) and (-) buttons to make adjustments.
- Return to the initial value by pressing the (+) and (-) buttons simultaneously (approx. 1 sec).

#### 6 (Cycle duty ratio setup)

Select setting item "DUTY" by moving the (JOG) button up or down. Use the (+) or (-) button to select the duty ratio.

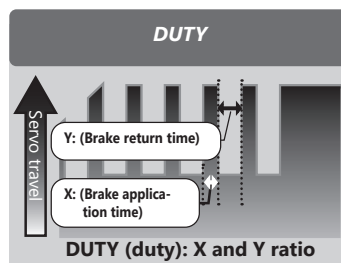

"LOW": Brake application time becomes shortest. (Brakes lock with difficulty).  
"HIGH": Brake application time becomes the longest (Brakes lock easily).  
(Remark) For low grip, set at the LOW side and for high grip, set at the HIGH side.

#### Duty ratio (DUTY)

LOW - MID - HIGH  
Initial value: MID

#### Adjustment buttons

- Use the (+) and (-) buttons to make adjustments.
- Return to the initial value by pressing the (+) and (-) buttons simultaneously (approx. 1 sec).

7 When finished with the adjustments, return to the MENU screen by pressing the (END) button.

#### Dial / Trim Setting

The brake return amount (AB.P), delay amount (DELY) and cycle (CYCL) can be controlled with digital dial or digital trim, with the function trim dial ([See page 104](#)).

#### Switch setting

Use SW1 or SW2 to switch the A.B.S. function ON/OFF.  
See the function select switch function ([See page 106](#)).

## Fail Safe Unit

When the T4PM PULS is used with the Futaba fail safe unit (FSU), it will operate as described below. However, FSU cannot be used in the high speed mode.

- When the FSU is connected to the throttle channel, and the A.B.S. function has been activated, the FSU LED will flash each time the servo operates. The reason for this is that the FSU responds to sudden data changes caused by A.B.S. function pumping operation. It does not mean that the fail safe function is activated. The servo will not be affected.

### Example of A.B.S. function setting when S9352HV used (There will be a slight difference depending on the state of the linkage.)

- Basic setting

AB.P: Approx. 30% (If this value is too high, the braking distance will increase.)

CYCL: 5~7

DUTY: (When grip is low: LOW side, when grip is high: HIGH side)

DELY: 10~15%

TG.P: Approx. 70%

- When the wheels lock, or the car spins, when the brakes are applied fully

AB.P: Increase from 30%

DUTY: Shift to "LOW" side

DELY: Reduce the delay

- When the braking effect is poor and the braking distance is long when the brakes are applied fully

AB.P: Decrease from 30%

DUTY: Shift to "HIGH" side

DELY: Increase the delay

### 1/5 scale car and other independent brakes and ABS

ABS can be independently set for the brakes which are controlled by the 3rd CH and 4th CH by using the brake mixing (BRAKE MIX) function described on [page 110](#). For more information, read the brake mixing (BRAKE MIX) item.



This menu has the following 4 functions:

- Servo neutral mode, which sets the throttle neutral ratio to 7:3 or 5:5.

\*Refer to country distributor WEB for detailed the following function explanation.

- Idle up, which raises the idling speed when starting the engine to improve engine starting performance of a gasoline car (boat).
- Neutral brake, which applies the brakes at the neutral position of the throttle trigger.
- Throttle off (engine cut), which stops the engine of a boat, etc. by operating the throttle servo to the low side regardless of the position of the throttle trigger.

Display "TH MODE" screen using the following method:

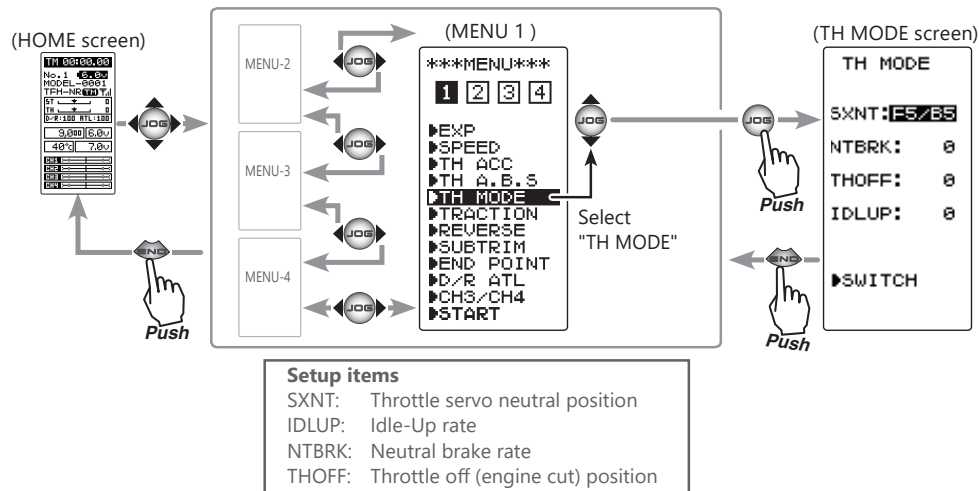

## Throttle servo neutral position "SXNT"

-This function allows selection of the forward side and brake (reverse) side operation ratio from 7:3 or 5:5 by changing the neutral position of the throttle servo.



### Selecting the throttle servo neutral position

#### 1 (Mode selection)

Select the setting item "SXNT" by moving the (JOG) button up or down. Select "F5/B5" or "F7/B3" by (+) or (-) button.

"F5/B5" = Forward 50%: Back50%.  
 "F7/B3" = Forward 70%: Back30%.

**Mode selection (SXNT)**  
 F5/B5, F7/B3

**Select button**  
 - Select with the (+) or (-) buttons.

#### 2 When finished with the setting, return to the MENU screen by pressing the (END) button.

## Idle-Up "IDLUP"

This is a function select switch function. The idle up switch must be set ([see page 106](#)).

This function is used to improve engine starting performance by raising the idling speed when starting the engine of a GP car (boat). It is also effective when you want to prevent the braking when the power is turned off during running, due to the effect of your gear ratio setting and choice of motor when operating an electronic car. However, considering safety, and to prevent the motor from rotating instantly when the power is turned on, the MC950CR, MC851C, MC602C, MC402CR, and other Futaba electronic motor speed controller (ESC) will not enter the operation mode if the neutral position is not confirmed. When using the MC950CR, MC851C, MC602C, MC402CR, or other Futaba ESC, confirm that the ESC is in the neutral position and the set is in the operation mode before setting the idle up function switch to ON.

### Operation

The throttle neutral position is offset to the forward side or brake side. There is no linkage locking, etc. because there is no change near the maximum operation angle even when the neutral position is offset by this function.

### Operation Display

While this function is ON, the LED blinks.

< NO SW >  
 If function's ON/OFF switch is not selected, <NO SW> is displayed.

The function select switch screen (page 106) can be displayed from this screen.

TH MODE

SXNT: F5/B5

NTBRK: 0

THOFF: 0

IDLUP: 0

<NO SW>

SWITCH

If the power switch is turned on while the idle-up switch is on, an audible alarm will be heard. Immediately set the Idle-Up switch to OFF.

WARNING

MIX WARN

IDLE UP

○

THOFF

○

NEUTRAL BRAKE

Warning display

### Idle-Up function adjustment

(Preparation)

- Use the function select switch to select the switch. ([page 106](#))

#### 1 (Idle-Up rate)

Select the setting item "IDLUP" by moving the (JOG) button up or down. Use the (+) and (-) buttons to set the Idle-Up rate.

#### Adjust button

- Adjust with the (+) and (-) buttons.
- Return to the initial value by pressing the (+) and (-) buttons simultaneously (approx. 1 sec).

#### Idle-Up rate (IDLUP)

D50 ~ D1, 0, U1 ~ U50

Initial value: 0

"D": Brake side

"U": Forward side

#### 2 When finished with the setting, return to the MENU screen by pressing the (END) button.

### Dial / Trim Setting

The function select dial function can control the Idle-up rate with digital dial or digital trim ([See page 104](#)).



# Neutral Brake "NTBRK"

This is a function select switch function. The neutral brake function ON/OFF switch must be set ([see page 106](#)).

The neutral brake, which applies the brakes at the neutral position of the throttle trigger, can be set. However, when using the MC950CR, MC851C, MC602C, MC402CR, or other Futaba ESC, confirm that the ESC is in the neutral position and the set is in the operation mode before setting the neutral brake function switch to ON, the same as the idle up function (page 64). In addition, when the idle up function or throttle off function (page 66) is set, this function has a higher priority than the neutral brake function.

### Reference

The ESC neutral brake function and T4PM PULS neutral brake function can be used simultaneously. However, when setting is difficult to understand, we recommend that only one neutral brake function be used.

### Dial / Trim Setting

When the neutral brake function is "ON", the neutral brake rate adjustment is automatically assigned to the throttle trim (DT1 - DT5 or DL1).

### Operation display

An LED blinks while the neutral brake function is active.

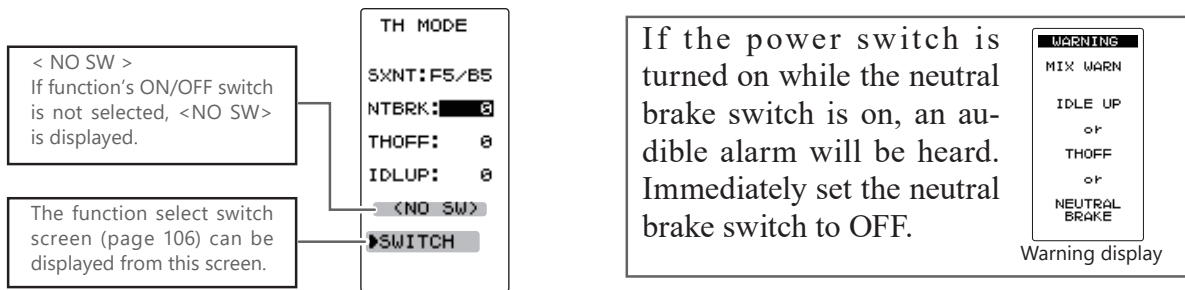

## Neutral Brake function adjustment

(Preparation)

- Use the function select switch to select the switch. ([page 106](#))

- 1 (Neutral brake rate)  
Select the setting item "NTBRK" by moving the (JOG) button up or down. Use the (+) and (-) buttons to set the neutral brake rate.

### Adjust button

- Adjust with the (+) and (-) buttons.
- Return to the initial value "0" by pressing the (+) and (-) buttons simultaneously for about 1 second.

### Brake rate (NTBRK)

0 ~ B100  
Initial value: 0

- 2 When finished with the setting, return to the MENU screen by pressing the (END) button.

### Effect of set value of other functions on neutral brake

Throttle side EPA function, or ATL function setting, also affects neutral brake side operation.

## Throttle Off (engine cut) "THOFF"

This is a function select switch function. The throttle off function ON/OFF switch must be set ([see page 106](#)).

The engine cut function stops the engine of a boat, etc. by operating the throttle servo to the slow side by switch regardless of the position of the throttle trigger and the setting of other functions (reverse function setting is effective).

### Dial / Trim Setting

The function select dial function can control the throttle-off position can be controlled with digital dial or digital trim ([See page 104](#)).

### Operation display

An LED blinks while the neutral brake function is active.

< NO SW >  
If function's ON/OFF switch is not selected, <NO SW> is displayed.

The function select switch screen (page 106) can be displayed from this screen.

TH MODE

SXNT: F5/B5

NTBRK: 0

THOFF: 0

IDLUP: 0

<NO SW>

SWITCH

If the power switch is turned on while the throttle-off switch is on, an audible alarm will be heard. Immediately set the throttle off switch to OFF.

WARNING

MIX WARN

IDLE UP

OF

THOFF

OF

NEUTRAL BRAKE

Warning display

### Engine Cut function adjustment

(Preparation)

- Use the function select switch to select the switch. ([page 106](#))

- 1** (Preset position setup)
  - Select the setting item "THOFF" by moving the (JOG) button up or down. Use the (+) and (-) buttons to set the preset position of the throttle servo.

#### Adjust button

- Adjust with the (+) and (-) buttons.
- Return to the initial value by pressing the (+) and (-) buttons simultaneously (approx. 1 sec).

#### Preset position (THOFF)

0 ~ B100  
Initial value: 0

- 2** When finished with the setting, return to the MENU screen by pressing the (END) button.

## Caution

### Always operate carefully before using this function.

While switch with preset function set is in the ON state, the servo (motor controller) is locked in the preset position and does not operate even if the throttle trigger is operated. If the servo is operated at the wrong setting, you may lose control of the car (boat).

Trigger operation with cornering on a slippery road surface is hard to get traction and smooth cornering cannot be done. By intermittently pulsing the throttle, you can smoothly navigate and on the ideal lines. Also, with a drift car, by intermittently operating the motor in the high point direction, a pseudo reverberator engine sound can be reproduced.

This function sets the ESC boost function to off (non-boost).

### Operation

- During throttle operation, the throttle servo is intermittently operated in the forward direction.
- You can set the amount of return to the slow side, the amount of delay, the speed of pumping, the operating point, and the duty ratio of pumping.
- You can choose the action on the slow side near the neutral and the action on the high point side.

Display "TRACTION" screen using the following method:

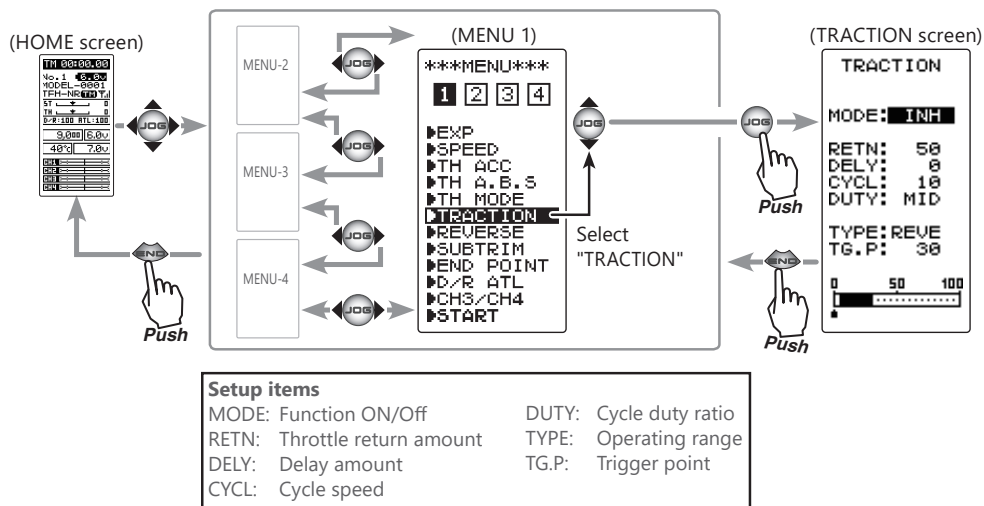

### - MODE: Function ON/OFF

Traction control functions ON/OFF setting. When using the Traction control function, set to "ON".

### - RETN : Throttle return

Set the ratio at which the servo returns to the slow side with respect to the trigger operation. If set to 0%, the traction control function will not work. At 50%, it returns to the neutral position at 50% (half), 100% of the trigger operation amount. 50% (1/2) of the trigger operation amount and when set to 100%, the servo returns to the neutral position.

### - DELY: Delay

Set the delay from when the throttle is operated until when the traction control operation starts. When set to 0%, the traction control function works without delay. At 50%, the traction control function works approximately 0.5 second later, and the traction control function works about 1.0 second later at 100%.

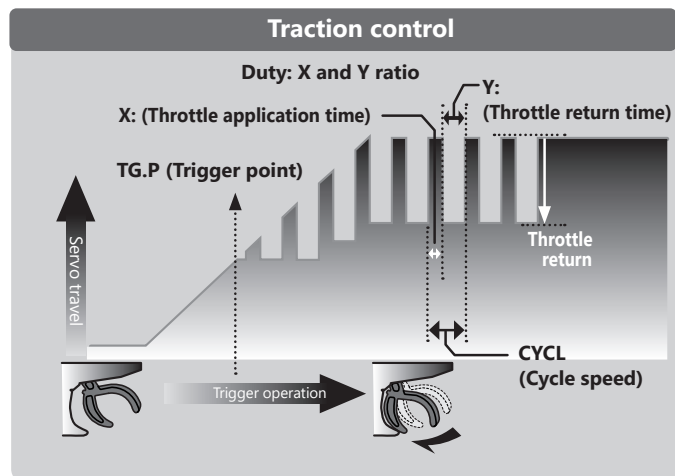

**- CYCL: Cycle speed**

Sets the pulse speed (cycle speed). The smaller the set value, the faster the pulse cycle.

**- DUTY: Duty ratio**

Set the ratio of the time to operate to the high side and the time to operate to the slow side in the pumping operation. The ratio can be set to HIGH, MID or LOW.

**- TG.P: Trigger point / TYPE: Operating range**

In the throttle operation, set the position of the trigger at which traction control starts to work. Normal / Reverse, reverse the throttle operation range where the traction control operates, with the trigger point as the boundary.

**Traction control function adjustment**

**1** (Function ON/OFF)

Select the setting item "MODE" by moving the (JOG) button up or down. Use the (+) or (-) button and set the function to the "ON" or "OFF" state.

- "INH": Function OFF.
- "ON": Function ON.
- "ON (OFF)": Switch OFF when setting switches.

**Function ON/OFF (MODE)**

INH,ON (OFF)

**Select button**

- Select with the (+) or (-) buttons.

**2** ("Throttle return" amount adjustment)

Select the setting item "RETN" by moving the (JOG) button up or down. Use the (+) and (-) buttons to adjust the delay amount.

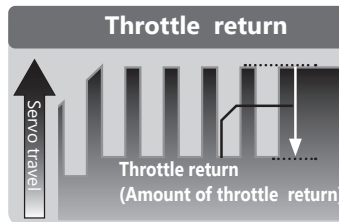

- "0": No return
- "50": Return to the 50% position of the brake operation amount
- "100": Return to the neutral position.

**Throttle return (RETN)**

1 ~ 50 ~ 100  
Initial value: 50

**Adjustment buttons**

- Use the (+) and (-) buttons to make adjustments.
- Return to the initial value by pressing the (+) and (-) buttons simultaneously (approx. 1 sec).
- The amount of throttle return varies depending on the EXP setting of the throttle etc.

**3** ("Delay" amount setup)

Select the setting item "DELY" by moving the (JOG) button up or down. Use the (+) and (-) buttons to adjust the return amount.

- "0": Function performed without any delay
- "50": Function performed after an approximate 0.5 sec delay.
- "100": Function performed after an approximate 1.0 sec delay.

**Delay (DELY)**

0 ~ 100  
Initial value: 0

**Adjustment buttons**

- Use the (+) and (-) buttons to make adjustments.
- Return to the initial value by pressing the (+) and (-) buttons simultaneously (approx. 1 sec).

**4** ("Cycle speed" adjustment)

Select the setting item "CYCL" by moving the (JOG) button up or down. Use the (+) and (-) buttons to adjust the cycle speed amount.

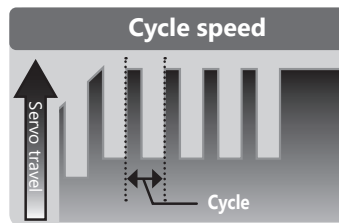

- The smaller the set value, the faster the pulse speed.

**Cycle speed (CYCL)**

1 ~ 30  
Initial value: 10

**Adjustment buttons**

- Use the (+) and (-) buttons to make adjustments.
- Return to the initial value by pressing the (+) and (-) buttons simultaneously (approx. 1 sec).

## 5 ("Duty ratio" setup)

Select the setting item "DUTY" by moving the (JOG) button up or down. Use the (+) and (-) buttons to set the duty ratio.

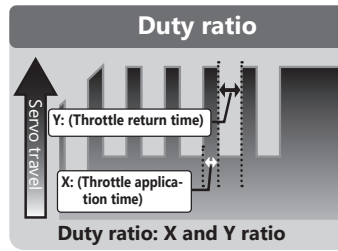

"LOW": Forward application time becomes shortest.  
"HIGH": Forward application time becomes longest.

**Duty ratio (DUTY)**  
LOW - MID - HIGH  
Initial value: MID

### Select button

- Use the (+) and (-) buttons to make adjustments.
- Return to the initial value by pressing the (+) and (-) buttons simultaneously (approx. 1 sec).

## 6 ("Trigger point" setup)

Select the setting item "TG.P" by moving the (JOG) button up or down. Use the (+) and (-) buttons to adjust the operation point.

- Sets the throttle trigger position at which the traction control function is performed. The number is the % display with the full throttle position made 100.

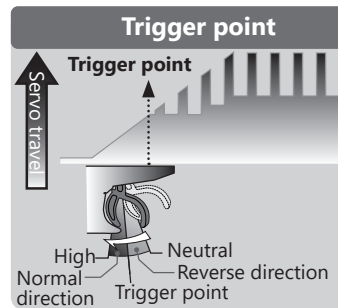

Select the setting item "TYPE" by moving the (JOG) button up or down. Use the (+) or (-) button to set the operating range.

"NORM": High range from the trigger point to the operating range.  
"REVE": Operating range from neutral to trigger point.

**Trigger point (TG.P)**  
5 ~ 95  
Initial value: 30

### Select button

- Use the (+) and (-) buttons to make adjustments.
- Return to the initial value by pressing the (+) and (-) buttons simultaneously (approx. 1 sec).

### Type (TYPE)

NORM, REVE

### Select button

- Use the (+) and (-) buttons to make adjustments.

7 When finished with the setting, return to the MENU screen by pressing the (END) button.

### Switch setting

Use SW1 or SW2 to switch the traction control function ON/OFF ([page 106](#)).

### Dial / Trim Setting

The throttle return amount, delay amount and cycle speed can be controlled with digital trim DT1 to DT5 or digital dial DL1 etc. with the dial select function ([page 104](#)).

### Fail Safe Unit

When the T4PM PULS is used with the Futaba fail safe unit (FSU), it will operate as described below. However, FSU cannot be used in the high speed mode.

- When the FSU is connected to the throttle channel, and the TRACTION function has been activated, the FSU LED will flash each time the servo operates. The reason for this is that the FSU responds to sudden data changes caused by TRACTION function pumping operation. It does not mean that the fail safe function is activated. The servo will not be affected.

# Start Function "START"

(Throttle system)

If the track is slippery and you begin to accelerate by pushing the trigger to full throttle, the car wheels will spin and the car will not accelerate smoothly. When the Start function is activated, merely operating the throttle trigger slowly causes the throttle servo to automatically switch from the set throttle position to a preset point so that the tires do not lose their grip and the car accelerates smoothly.

### Without "Start" function

Car does not accelerate



### With "Start" function

Tires grip the track firmly- Car accelerates



## Operation

- When the throttle trigger is moved to the preset position (TRIGGER POINT), the throttle servo moves to the preset position.
- When the throttle trigger is operated slowly so that the wheels will not spin, the car automatically accelerates to the set speed.
- This function is effective only for the first throttle trigger operation at starting. This function has to be activated before every start.
- When the throttle trigger is returned slightly, the Start function is automatically deactivated and the set returns to normal throttle trigger operation.

Display "START" screen using the following method:

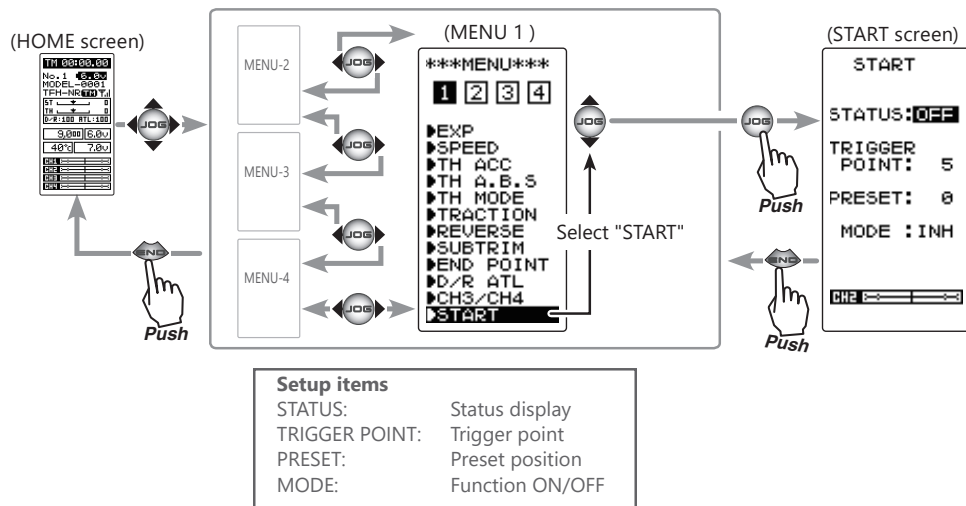

## Start function adjustment

### 1 (Function ON/OFF)

Select the setting item "MODE" by moving the (JOG) button up or down. Use the (+) or (-) button and set the function to the "ON" or "OFF" state.

"INH": Function OFF.  
"ACT": Function ON.

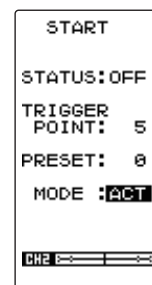

Function ON/OFF (MODE)  
INH,ACT

#### Select buttons

- Select with the (+) or (-) buttons.

## 2 ("Trigger point" setup)

Select the setting item "TRIGGER POINT" by moving the (JOG) button up or down. Use the (+) and (-) buttons to adjust the delay amount.

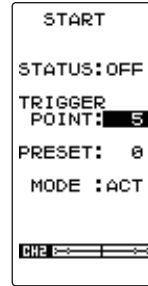

### Trigger point (TRIGGER POINT)

5 ~ 95  
Initial value: 5

#### Set button

- Use the (+) and (-) buttons to make adjustments.
- Return to the initial value by pressing the (+) and (-) buttons simultaneously (approx. 1 sec).

## 3 ("Preset position" setup)

Select the setting item "PRESET" by moving the (JOG) button up or down. Use the (+) and (-) buttons to adjust the return amount.

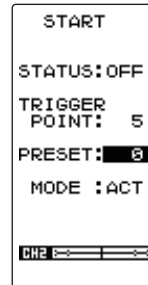

### Preset position (PRESET)

0 ~ 100  
Initial value: 0

#### Adjustment buttons

- Use the (+) and (-) buttons to make adjustments.
- Return to the initial value by pressing the (+) and (-) buttons simultaneously (approx. 1 sec).

## 4 ("Ready" setup)

Select the setting item "STATUS" by moving the (JOG) button up or down, and press the (JOG) button simultaneously for about 1 second, the display will change to [RDY] and wait for trigger operation.

To set the switch to the [RDY] state, switch settings

Set the start switch in the function [\(page 106\)](#).

In the [RDY] state, if the throttle trigger is operated to the position of the "TRIGGER POINT", the throttle servo moves to the servo operation position set with preset. It is canceled when the throttle trigger is returned.

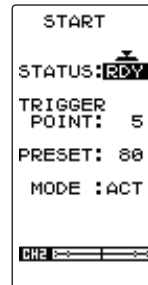

### Status display (STATUS)

OFF: Start function OFF  
RDY: Wait for trigger operation  
ON: Start function ON

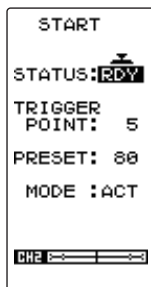

Operate (or pass) the throttle trigger from the status display "RDY" to the trigger position.

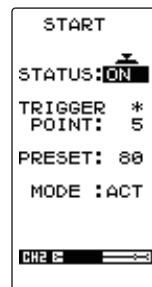

The throttle servo moves to the "PRESET" position and the status display is "ON".

Return the throttle trigger a slightly.

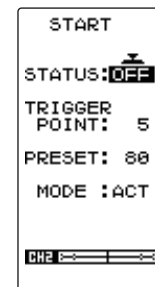

The Start function is automatically deactivated and the set returns to normal throttle trigger operation. The status display is "OFF".

## 5 When finished with the setting, return to the MENU screen by pressing the (END) button.



# Steering Dual Rate/ Throttle ATL "D/R ATL"

## D/R (Steering dual rate)

The steering left and right servo travels are adjusted simultaneously. This setting is linked to transmitter grip trim lever DT4. When DT4 is assigned another function, dual rate can be adjusted with this screen.

## ATL (Throttle ATL)

This function decreases the set value when the braking effect is strong and increases the set value when the braking effect is weak. This function is linked to transmitter grip trim lever DT5. When DT5 is assigned another function, this function can be set with this screen.

Display "D/R ATL" screen using the following method:

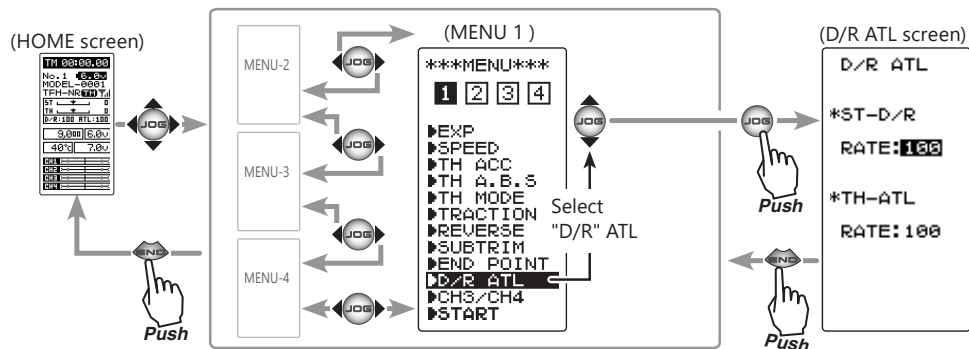

### Dual rate adjustment

- 1** (Dual rate adjustment)  
Select the setting item ST-D/R "RATE" by moving the (JOG) button up or down. Adjust the servo travel with the (+) and (-) buttons.
- 2** When finished with the setting, return to the MENU screen by pressing the (END) button.

**D/R rate (RATE)**  
0~100%  
Initial value: 100

- Adjustment buttons**
- Use the (+) and (-) buttons to make adjustments.
  - Return to the initial value by pressing the (+) and (-) buttons simultaneously (approx. 1 sec).

### ATL function adjustment

- 1** (Brake amount adjustment)  
Select the setting item TH-ATL "RATE" by moving the (JOG) button up or down. Adjust the servo travel with the (+) and (-) buttons.
- 2** When finished with the setting, return to the MENU screen by pressing the (END) button.

**ATL rate (RATE)**  
0~100%  
Initial value: 100

- Adjustment buttons**
- Use the (+) and (-) buttons to make adjustments.
  - Return to the initial value by pressing the (+) and (-) buttons simultaneously (approx. 1 sec).



The channel 3/4 servo position can be set from the this screen. When CH3/4 is assigned to a trim dial or switch by the trim dial function (page 104) or the switch function (page 106), this setting is linked to that.

When CH3/4 is not assigned to a trim dial or switch, it can be set with this screen.

When CH3/4 is assigned to a switch by the switch function, you cannot adjust the CH3/4 via the screen.

Display "CH3/CH4" screen using the following method:

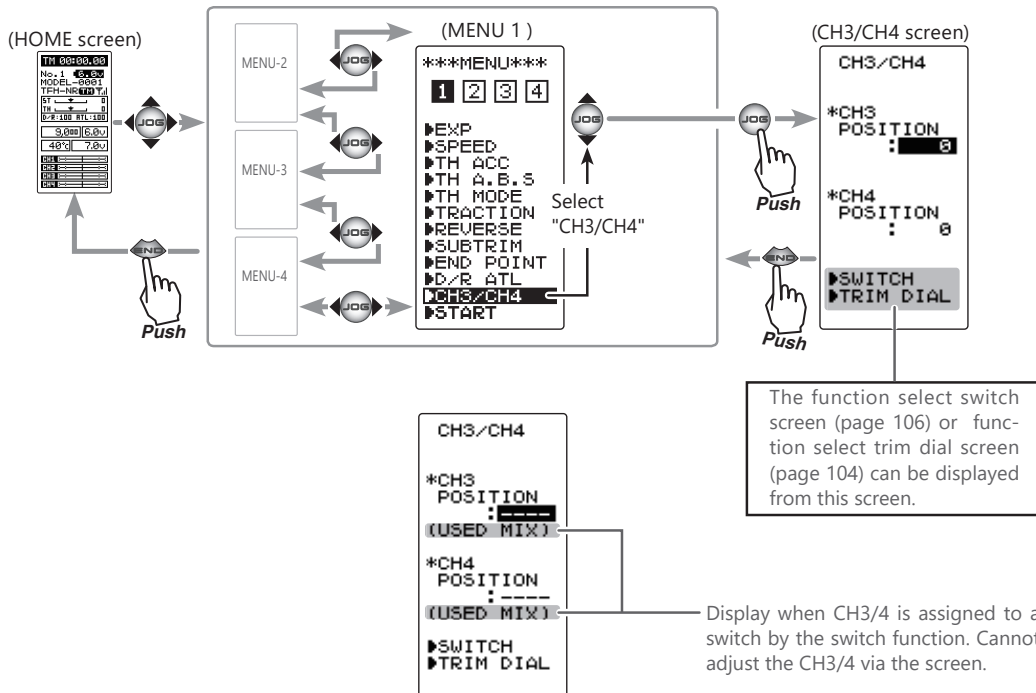

## Rate/position adjustment on channel menu screen

- 1 (Function selection)**  
On each CH3/CH4 screen select CH3 "POSI" or CH4 "POSI" by moving the (JOG) button up or down.
- 2 (Position setting/rate adjustment)**  
Use the (+) and (-) buttons to adjust the channel 3 or channel 4 position.
- 3** When finished with the setting, return to the MENU screen by pressing the (END) button.

**Channel 3 position (POSI)**  
**Channel 4 position (POSI)**  
0~100%  
Initial value: 0

**Adjust button**  
- Adjust with the (+) and (-) buttons.  
- Return to the initial value by pressing the (+) and (-) buttons simultaneously (approx. 1 sec).

# Model Selct "MDL SELE"

Forty model data (data for 40 R/C cars) can be saved in the T4PM PULS transmitter. This menu selects the model and copies data between models.

Display "MDL SELE" screen using the following method:

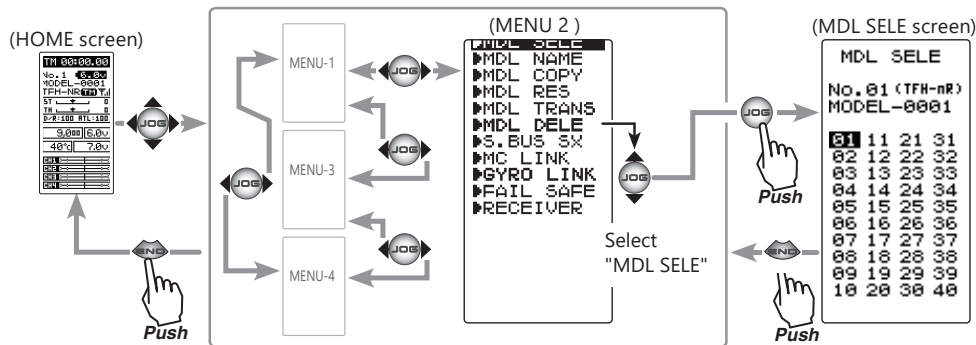

## Using the model select function

- 1 (Model #. selection)**  
Select the model number by moving the (JOG) button up/down or left/right. "01" ~ "40" are displayed.

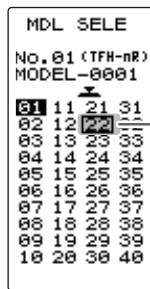

**Model #.**  
01~40  
Move the cursor to select model # with the (JOG) button.

- 2 (Model select execution)**  
Press the (JOG) button for approximately 1 second. A beeping sound is generated and the model is selected.

- Model change is complete when the model number and model name on the screen change.

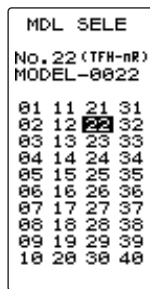

- 3** When finished with the setting, return to the MENU screen by pressing the (END) button.

# Model Name "MDL NAME"

This function allows you to assign a ten character name to each model memory and user name.

Display "MDL NAME" screen using the following method:

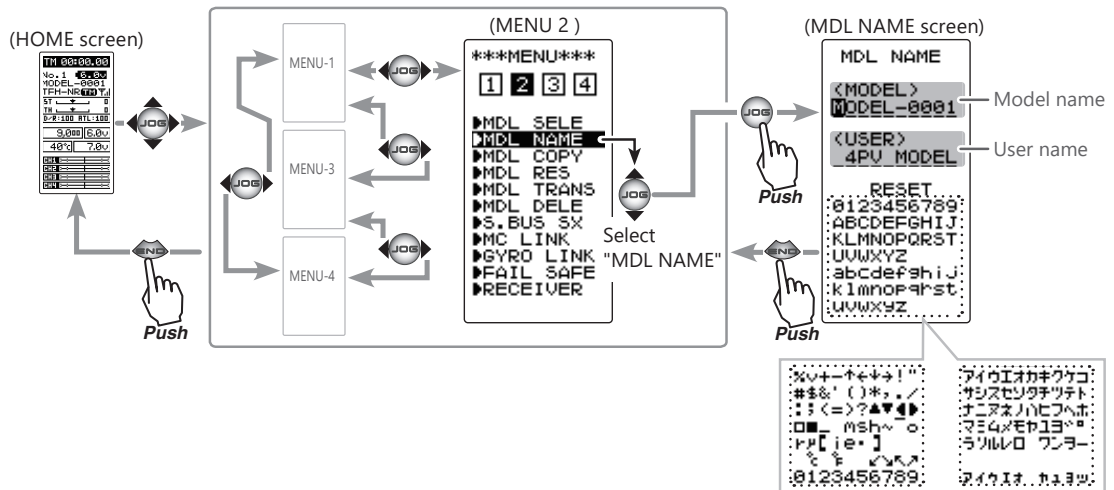

## Setting the model name and user name

- (Move the cursor to the character you want to change.)  
Select the model name or user name character you want to set or change by moving the cursor by the (+) or (-) button. The selected character blinks.

When (JOG) button left or right operation is performed from both the left and right ends of the character list, the page (all 3 pages) is changed and the character set is selected.

(KATAKANA of the 3rd page is displayed when "KANA" is set by the "SYSTEM" function "MENU".)

Move the cursor to the character you want to change by (+) or (-) button.

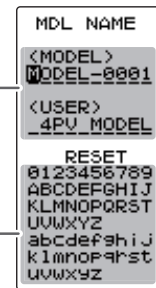

Select the character by (JOG) button.

- (Selecting the character to be used)

Move the (JOG) button up, down, left or right to select the character you want to use from the list at the bottom of the screen. The selected character blinks. Now, press the (JOG) button. The character is entered and the model name or user name character. The cursor will automatically move to the right for the next characters.

Use the (JOG) button also to move the cursor to "RESET". Press the button approximately 1 second. You'll hear a beeping sound, which indicates that the model name has been initialized into the factory settings. A beeping sound is generated and the model name is initialized to the factory setting.

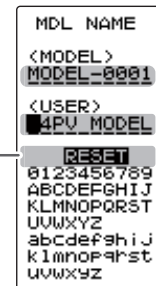

Move the cursor to "RESET" by the (JOG) button up or down operation.

- When finished with the setting, return to the MODEL screen by pressing the (END) button.

# Model Copy "MDL COPY"

The contents of the currently selected model data can be copied to another model.

-The models copied in the microSD card can not be used by directly calling from the card. Please copy it to the T4PM PULS main unit when using it.

-If the model data of another transmitter is saved to the microSD card, the model data is not displayed in this list.

-There is no limit to the number of model data on the microSD card, but it differs depending on the capacity size of the card. However, the model data displayed in the list is a maximum of 100 models. In addition, there is no rule in the display order.

-When displaying the copy menu or while executing the copy operation, the buzzer with the same pitch as the key operation may sound continuously, but this is not a malfunction.

Display "MDL COPY" screen using the following method:

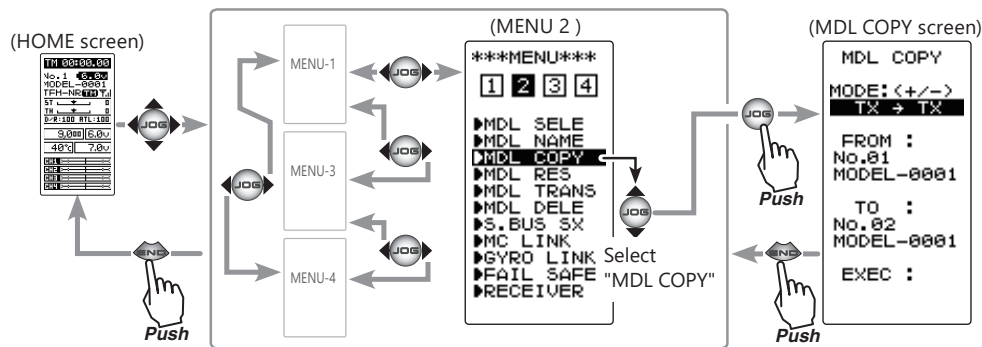

## Using the model copy function

### 1 (Select a mode)

In "MODE", select the copy source and copy destination devices.

Select the setting item "MODE" by moving the (JOG) button up or down. Use the (+) or (-) button and set the copy source and copy destination devices.

"TX → TX": Copy data from any model to another model on the T4PM PULS main unit.

"TX → SD": Copy the model data in the T4PM PULS memory to the SD card.

"SD → TX": Copy the model data in the SD card to the T4PM PULS main unit memory.

"SD → SD": Make a copy of the model data in the SD card to the same SD card.

#### MODE

- TX → TX
- TX → SD
- SD → TX
- SD → SD

#### Select button

- Select with the (+) or (-) buttons.

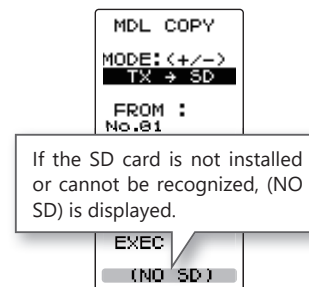
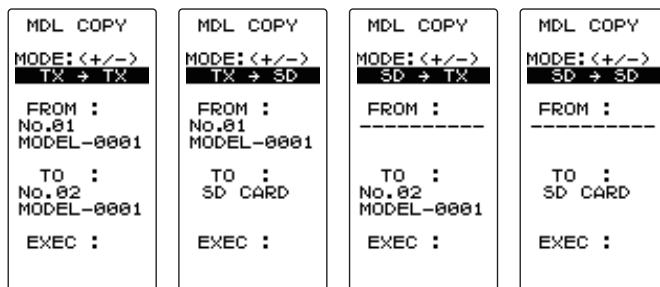

## 2 (Copy source model selection)

Select the setting item "FROM" by moving the (JOG) button up or down, and press the (JOG) button to display a list of model numbers.

- When the copy source is "TX", a list of 1 to 40 models is displayed.
- When the copy source is "SD", the model name is displayed. (If the number of models that do not fit on one page is stored, arrows will be displayed on the left and right of the page number on the screen. (JOG) Move the page by moving the button left or right.)

### Select button

- Select with the (JOG) button.

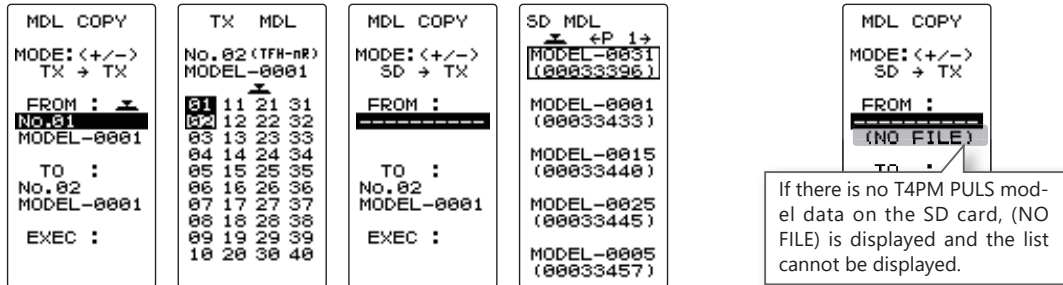

Select the copy destination model with the (JOG) button up / down or left / right operation, and press the (JOG) button. Return to the copy screen.

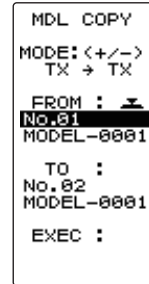

### Select button

- Select with the (JOG) button.

## 3 (Copy destination model selection)

Select the setting item "TO" by moving the (JOG) button up or down, and press the (JOG) button to display a list of model numbers.

- When the destination is "TX", a list of 1 to 40 models is displayed.
- When the copy destination is "SD", the list is not displayed even if the (JOG) button is pressed for additional copying to the SD card.

Select the copy destination model with the (JOG) button up / down or left / right operation, and press the (JOG) button. Return to the copy screen.

### Select button

- Select with the (JOG) button.

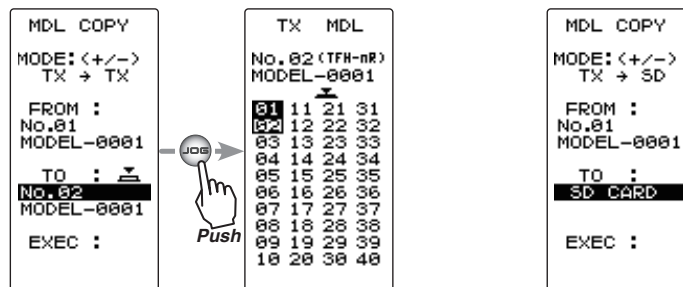

---

#### 4 (Model copy execution)

Select the setting item "EXEC" by moving the (JOG) button up or down, and press the (JOG) button. A beeping sound is generated and the copying is complete.

**Select button**  
- Select with the (JOG) button.

-Copying is complete when "COMPLETE!" is displayed on the screen.

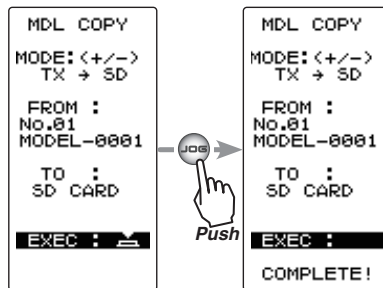

---

#### 5 When finished, return to the MENU screen by pressing the (END) button.

## Model Reset "MDL RES"

This function resets and initializes the contents of the currently selected model data. However, the adjuster function (ADJUSTER), system setting (SYSTEM), and type of receiver system (RECEIVER) are not initialized.

Display "MDL RES" screen using the following method:

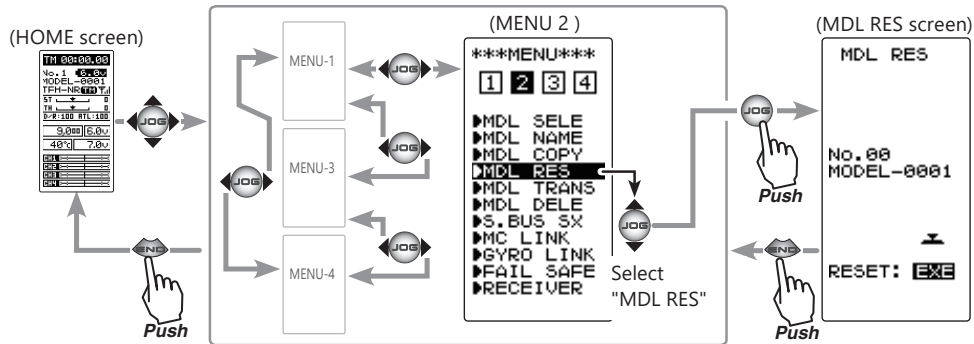

### Using the model reset function

#### 1 (Model reset execution)

Press the (JOG) button for approximately 1 second. A beeping sound is generated and the model is selected.

-Resetting is complete when "COMPLETE!" is displayed on the screen.

Reset execution button  
- (JOG) button pressed.

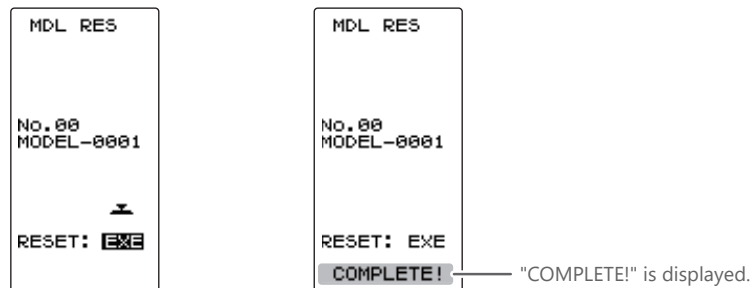

#### 2 When finished with the setting, return to the MENU screen by pressing the (END) button.

The set receiver system and T-FHSS receiver ID remain even if the model is reset. The same receiver can be used as is without re-linking.

## Data Transfer "MDL TRANS"

This function copies the model memory data of one T4PM PULS to another T4PM PULS. Connect the communication port of both T4PM PULSs with the optional DSC cable (For updating transmitter with CIU-3).

**Note:** If the T4PM PULS battery voltage drops, the display switches to low battery display. Therefore, use this function when there is ample battery capacity remaining.

**Note:** Since the receiving side writes the new contents of the currently selected model memory, always check the model number before executing this function.

Data is not interchangeable with another type of transmitter.

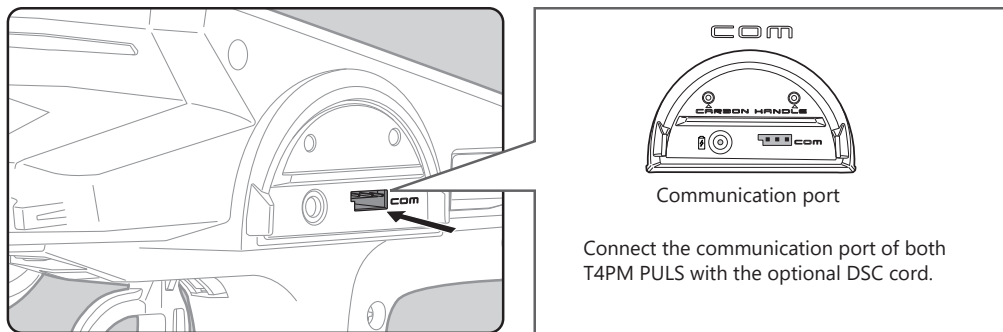

Display to "MDL TRANS" screen using the following method:

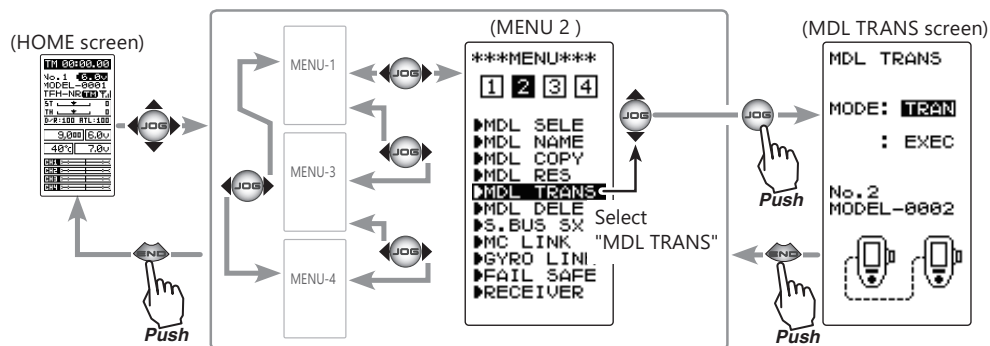

### Using the Data Transfer function

(Preparation)

- Connect the communication port of both transmitters with the optional DSC cord.
- Turn on the power of both T4PM PULSs. Select the model number of the transfer side and the receiving side with the model select function ([page 74](#)).

- 1 Display the data transfer function screen in the above manner.

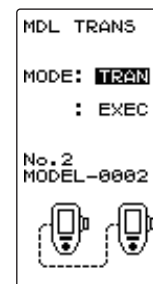



## 2 (Select the setting item)

Select "MODE" by moving the (JOG) button up or down, and select the transfer side and receiving side using the (+) or (-) button.

"TRAN": Data transfer side.  
"RECV": Data receiving side.

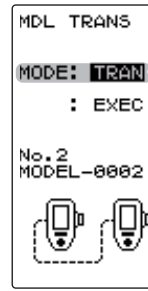

**Mode selection**  
"TRANSFER" "RECEIVE"  
**Setup item selection**  
- Select by (JOG) button up or down operation.  
**Mode change button**  
- Use the (+) and (-) buttons to make adjustments.

## 3 (Data transfer execution)

Select the setting item "EXEC" by moving the (JOG) button up or down on both transmitters.

First, press the receiving side "RECV" transmitter (JOG) button. The message "RCV WAIT.." appears and countdown begins.

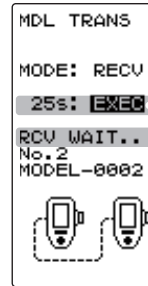

**Transfer execution button**  
- (JOG) button pressed.  
\*30 seconds wait is displayed on the receive side screen.

Within 30 seconds, press the transfer side "TRANS" transmitter (JOG) button. (If data transfer is not executed within 30 seconds, an error will be displayed at the receiving side "RECV" transmitter.)

- "COMPLETE!" is displayed on the screen of the receiving side "RECV" transmitter and data transfer is ends.

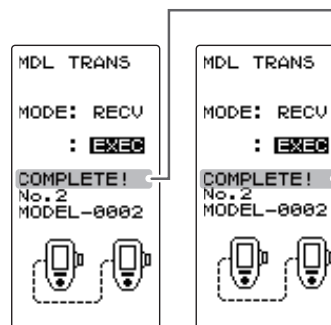

"COMPLETE!" is displayed.

-If "RCV ERROR!" is displayed on the screen of the receiving side "RECEIVE" transmitter, data transfer was not performed normally. Check the connection and repeat steps 1 → 3. Since the transfer side "TRANS" transmitter only sends, "COMPLETE!" is displayed even when data transfer was not performed normally.

Data transfer can also be canceled before the end of transfer by operating the (JOG) button at a T4PM PULS that is waiting to receive data.

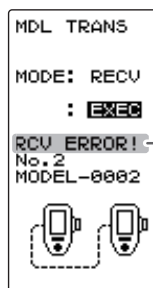

"RCV ERROR!" is displayed.

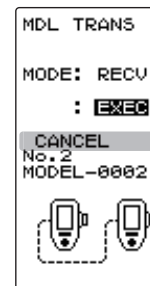

"CANCEL" is displayed.

## 4 When finished with the setting, return to the MENU screen by pressing the (END) button.

# Model Delete (Saved on SD card) "MDL DELE"

This function deletes model data saved on the SD card.

Display to "MDL DELE" screen using the following method:

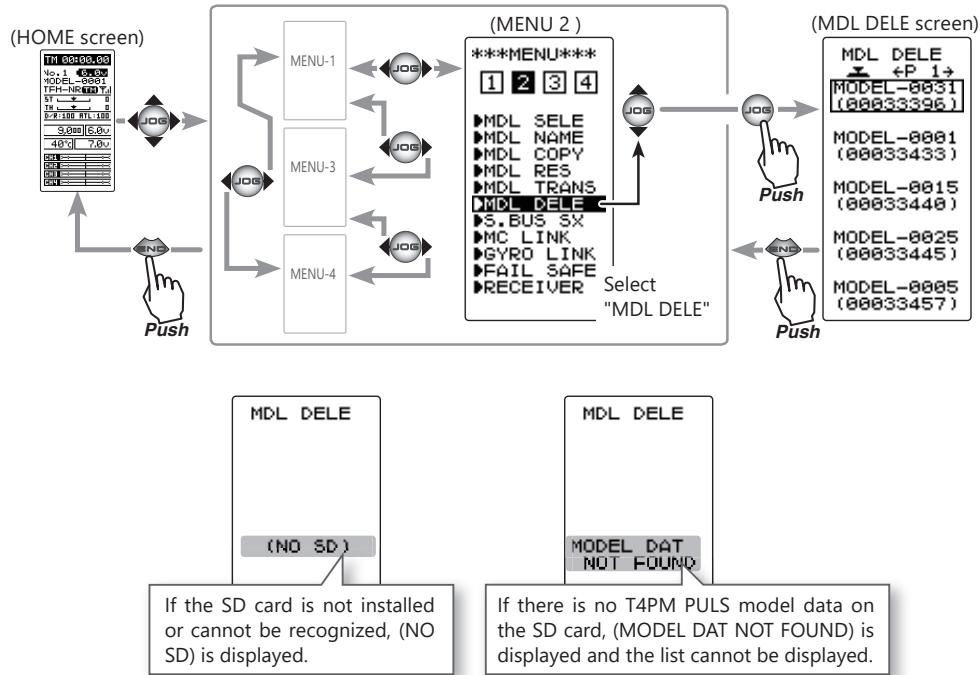

## How to delete model data in the SD card

- 1 (Select model to delete)**  
 Select the model to delete by moving the (JOG) button up or down.  
 -When the number of models that do not fit on one page is saved, arrows are displayed on the left and right of the page number on the screen. Operate the (JOG) button left or right to move the page.

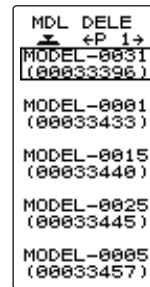

**Select button**  
 - Select with the (JOG) button.

- 2 (Perform delete)**  
 After selecting the model to delete, press the (JOG) button. The message "DELETE ARE YOU SURE?" is displayed. When you press the (JOG) button, a beep sounds and the model data is deleted.

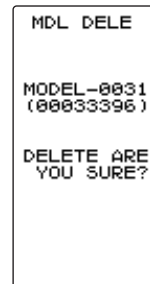

**Execution button**  
 - Pressing the (JOG) button.

- 3** When finished with the setting, return to the MENU screen by pressing the (END) button.

## Fail-safe Mode (F/S)

This function moves each servo to a preset position when the receiver cannot receive the signals from the transmitter for some reason.

-The fail-safe data is transferred from the transmitter to the receiver 10 seconds after the transmitter power was turned on. The data is transferred every 5 seconds after that. Be careful because normally the transmitter power is turned on first and the receiver power is turned on next and the data is transferred for approximately 10 seconds after the receiver power is turned on.

-For gas power cars, for safety we recommend that this fail-safe function be used to set the throttle channel in the direction in which the brakes are applied.

## Hold mode (HOLD)

This function holds the receiver in its position immediately before reception was lost.

## Off mode (OFF)

This function stops output of signals to the servos and places the servos into the free state when the receiver cannot receive.

\*The F/S, HOLD, and OFF modes are automatically reset when signals from the transmitter can be received again.

## Battery fail-safe function (B-FS)

If the receiver battery voltage drops below a certain value when this function is enabled, the throttle servo moves to the position set by fail-safe function. When the battery voltage recovers, the battery fail-safe function is automatically reset.

-This function cannot be used when the throttle (TH) is not set to fail-safe (F/S).

Display to "FAIL SAFE" screen using the following method:

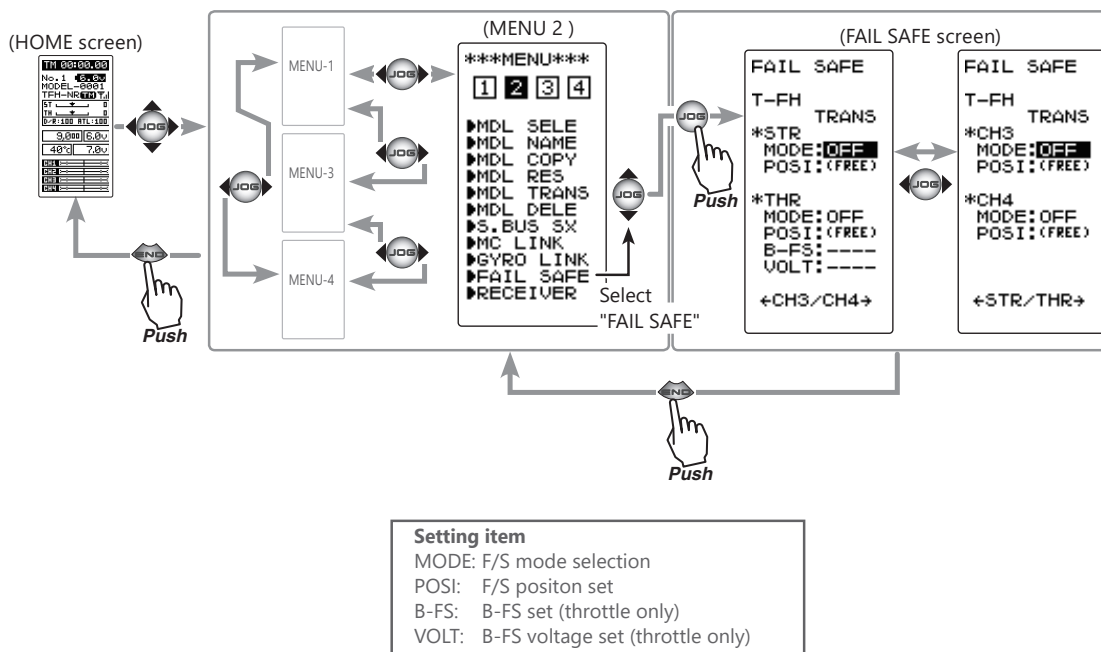

## Fail-safe mode selection

(Preparation)

- Select the channels "MODE" to be set by moving the (JOG) button up, down, left or right.

### 1 (Mode selection)

Select the mode by (+) or (-) button.  
(Each channel can be individually set.)

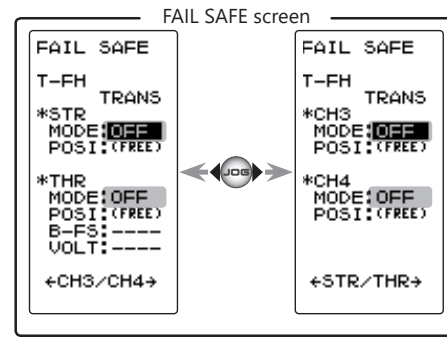

- ### 2
- When finished with the setting, return to the MENU screen by pressing the (END) button.  
When setting fail-safe, set the servo position by the following method.

## Fail-safe function setup

### 1 (Servo position setup)

When the fail-safe function operates, select the setting item "POSI" by moving the (JOG) button up or down. The steering wheel, the throttle trigger or 3rd, 4th channel dial remains in the desired operation position. When the (JOG) button is pressed for approximately 1 second, the servo position is displayed and you can confirm that the function was set.

(Each channel can be set similar.)

- ### 2
- When finished with the setting, return to the MENU screen by pressing the (END) button.

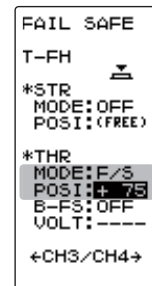

**F/S mode**  
OFF, HOLD, F/S

**F/S mode selection**  
- Select with the (+) or (-) buttons.

**F/S position setup button**  
- The (JOG) button is pressed for approximately 1 second.

## Battery fail-safe function ON/OFF

(Preparation)

- Select the setting item by moving the (JOG) button up or down. For Battery F/S function select "OFF" or "ACT" of "B-FS".

For voltage setting, select VOLT. (This applies to the T-FHSS system only.)

The S-FHSS system is fixed at 3.8v.

### 1 (Battery fail-safe function ACT/OFF)

The battery fail-safe function ACT/OFF and voltage setting which activates the B-FS function can be switched by (+) or (-) button.

- ### 2
- When finished with the setting, return to the MENU screen by pressing the (END) button.

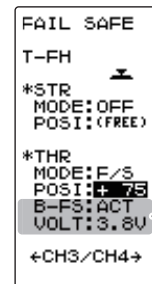

#### Battery fail-safe function

OFF, ACT  
Initial value: OFF

#### Select button

- Select with the (+) or (-) buttons.

#### B-F/S Voltage

3.8, 4.0, 4.2, 4.4, 4.6, 4.8, 5.0, 5.3, 5.6, 5.9, 6.2, 6.5, 6.8, 7.1, 7.4(V)  
Initial value 3.8v

#### Select button

- Select with the (+) or (-) buttons.

Example:

Ni-MH /Ni-Cd 4cell---3.8V

Ni-MH /Ni-Cd 6cell---4.4V

LiFe 2cell---4.8V

Li-Po 2cell---5.6V



## S.BUS Link Function "S.BUS SX"

This is a special function which allows Futaba S.BUS/S.BUS2 servo parameter changes to be set by the T4PM PULS transmitter. However, some data changes require a PC and S-Link software. There are two ways to set Futaba S.BUS / S.BUS 2 servo directly by connecting it to the communication port of the transmitter and wirelessly setting it with the servo still connected to the receiver. When setting with wires, please use optional extension cord for servo as necessary. (SR mode setting is for T4PM PULS only; it cannot be set with S-Link software.) Also, there are restrictions on wireless setting, so read the following "Notes" below.

### NOTE:

- If shutting off while writing the parameters, the servo may fail. Please use this function with sufficient battery power.
- For safety reasons, it is not possible to change between normal mode and SR mode with wireless setting. To change the mode, connect the servo to the communication port and switch. However, for servos set to SR mode, SR1 / SR2 / SR3 can be switched by wireless setting.
- Wireless setting cannot be used if a device that converts signals such as gyro and FSU (Failsafe Unit) etc. are connected between the receiver and the servo.
- A receiver compatible with the wireless setting function is required. (As of August 2022, R334SBS / R334SBS-E is compatible with wireless setting. Please update the previous receiver to version 2.0 or later.)
- For the servo set to SR mode, attach the attached SR label so that the mode can be recognized. (SR label included only with R334SBS / R334SBS-E)

### Warning

- ❗ In the wireless setting, there is a danger that a car (boat) can become unexpectedly uncontrollable, because the servo temporarily stops working during communication. For safety, in case of electric car (boat), please set with driving wheel (boat propeller) not touching the road surface (water surface). Also, in the case of an internal combustion engine car (boat), be sure to stop the engine before entering wireless set-up mode.

### Caution

- ❗ When connecting an S-BUS servo that does not support high voltage, connect a battery matched to the servo specifications.

High voltage servo support voltage is supplied from the transmitter. If a servo that does not support high voltage is connected, unreasonable force will be applied to the servo and will cause trouble.

- ⊘ Do not disconnect the servo connector or turn off the transmitter power while writing parameters.

It may cause the servo to malfunction.



## Connection between wired transmitter and servo

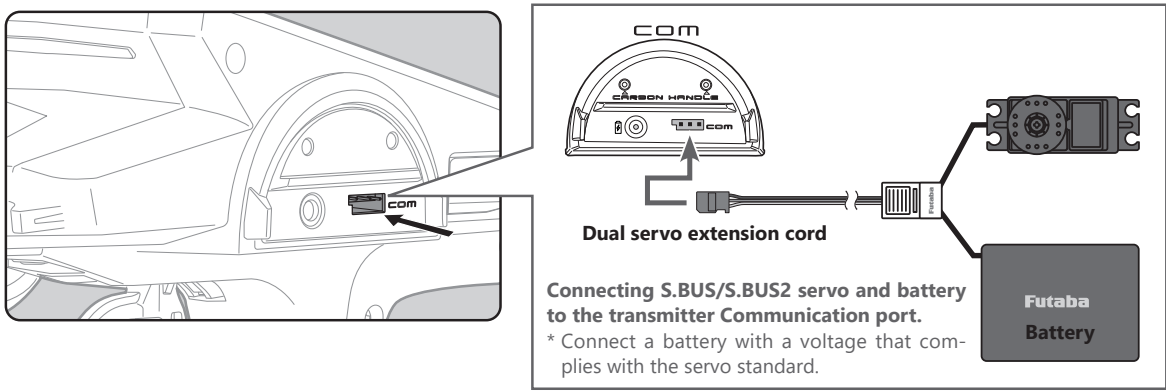

## Connection between wireless receiver and servo

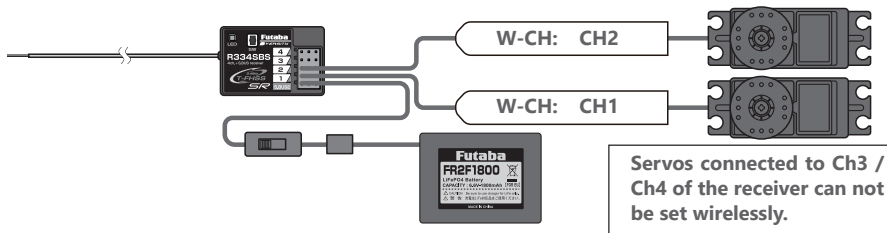

Display "S.BUS SX" screen using the following method:

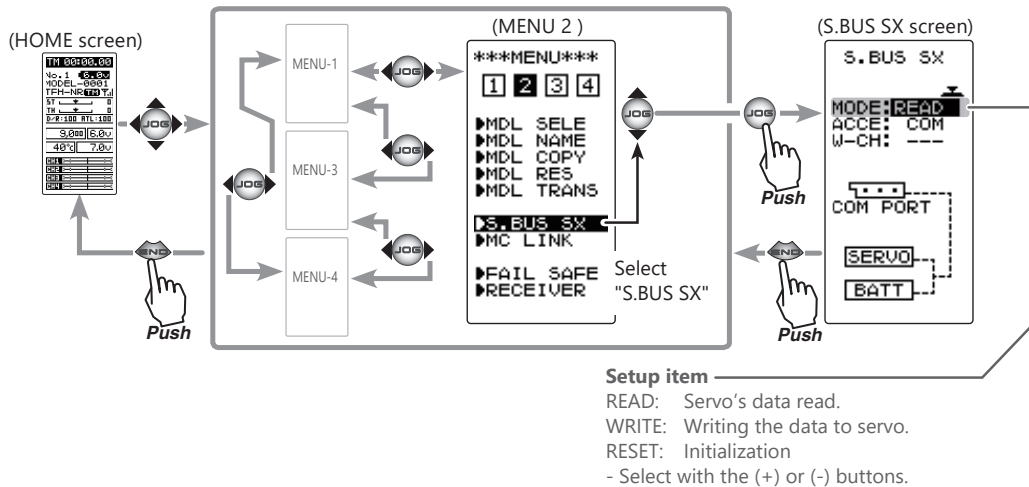

## Using the S.BUS servo function

(Preparation)

- Connect S.BUS or S.BUS2 servo with reference to the above connection diagram.
- Connect the battery to a S.BUS/S.BUS2 servo.
- Be sure to use the wired method when changing the setting of SR mode. The mode can not be changed with wireless setting.

- 1 Turn on the power switch of the transmitter.  
In the case of wireless, turn on the battery switch of the receiver and check the operation of the servo. The S.BUS SX screen is displayed.

**2** Execute this function to read the connected servo type and the data currently set at the servo. Select the setting item "ACCE" by moving the(JOG) button up or down, and select the reading method with (+) or (-) button.

- Wired: COM
- Wireless: W-LES

For wireless, move the cursor to the setting item "W-CH" and select the servo connection channel with the (+) or (-) button.

- Channel 1 servo: CH1
- Channel 2 servo: CH2

Select the setting item "MODE" by moving the (JOG) button up or down. Select "READ" by (+) or (-) button, and press the (JOG) button.

- "COMPLETE!" blinks on the screen and the servo ID and currently set contents are read.

- If "COM-ERROR" blinks on the screen, communication with the servo is not being performed normally. Check the T4PM PULS and servo connection and the battery connection to servo and repeat READ.

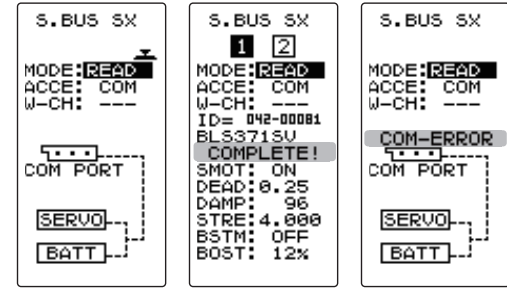
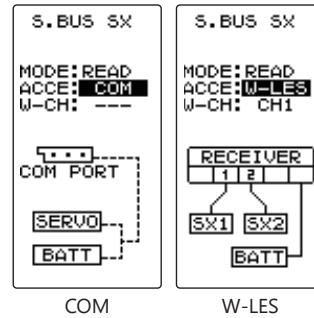

**3** (Writing to S.BUS/S.BUS2)

Execute this function to write the setting data to the servo. See pages 89 to 90 for the setting data contents. Select the setting item "MODE" by moving the (JOG) button up or down. Select "WRITE" by (+) or (-) button, and press the (JOG) button.

- "COMPLETE!" blinks on the screen and the setting data is written to the servo.

- If "COM-ERROR" blinks on the screen, communication with the servo is not being performed normally. Check the T4PM PULS and servo connection and the battery connection to servo and repeat WRITE. In addition, if (NO DATA) is displayed on the T4PM PULS screen, "WRITE" cannot be selected because there is no setting data to be written.

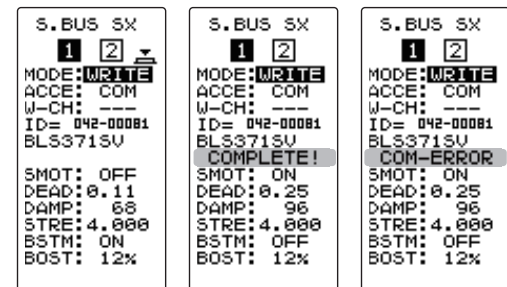

**4** (Initialization)

This function writes the servo setting data set at the factory to the connected servo. Perform "READ" before performing initialization.

Select the setting item "MODE" by moving the (JOG) button up or down. Select "RESET" by (+) or (-) button, and press the (JOG) button.

- "COMPLETE!" blinks on the screen and the initial data is written to the servo.

- If "COM-ERROR" blinks, communication with the servo was not performed normally. Check the T4PM PULS and servo connection and the battery connection to servo, and repeat RESET, when (NO DATA) is displayed on the T4PM PULS screen "RESET" cannot be selected because there is no write initial data.

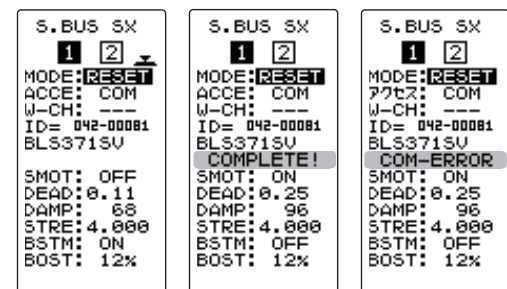



## Display data list

- The type and data of the loaded servo are displayed. Since there are page two setting items, change the page as follows.

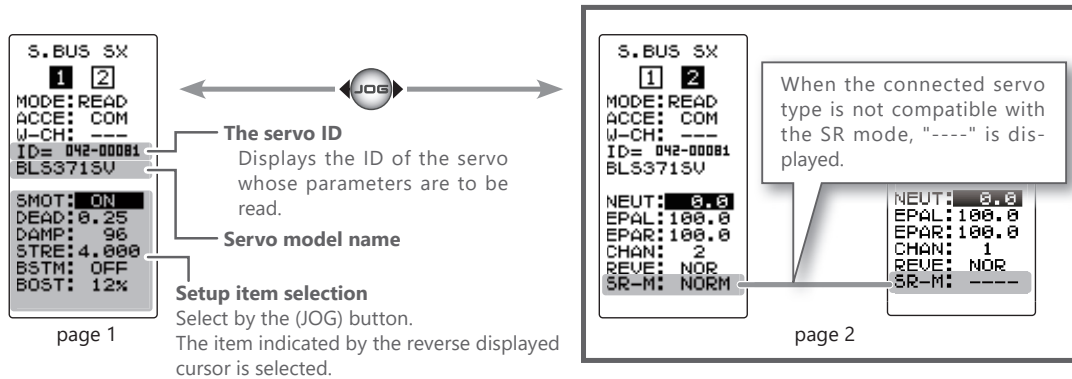

- Do not plug in or disconnect servos, or connect other servos while keeping the screen where data was read by "READ". Be sure to connect the servo in the state where "WRITE" or "RESET" is finished, or press the HOME button to access the accessory menu screen.
- The loaded data can not be written to another servo.

## SR mode setting (Wired only)

- Since the change function of SR and normal takes precedence over other parameter settings, this setting is done first. Also, when SR mode is changed, it is initialized to that mode. The reading the servo referring to page 87.

- Select the setting item "SR-M" on page 2 by moving the(JOG) button left, right, up or down, and select the NORM, SR1, SR2, or SR3 with (+) or (-) button.

- There is one type of servo for SR-1 selection of SR mode.
- When servo is set to SR mode, SR 1, SR 2 or SR 3 can be changed by wireless setting.

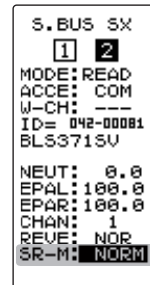

- (Writing to S.BUS/S.BUS2)

Since "CHANGE?" Is displayed at the bottom of the screen, press the (JOG) button.

-After "WAIT ..." is displayed, the "COMPLETE!" blinks on the screen and the setting data is written to the servo.

-If "COM-ERROR" blinks on the screen, communication with the servo is not being performed normally. Check the T4PM PULS and servo connection and the battery connection to servo and repeat writing.

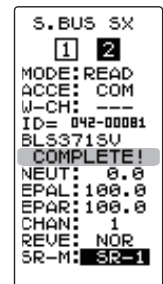
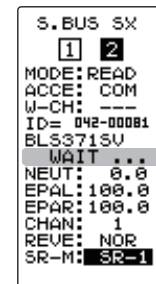
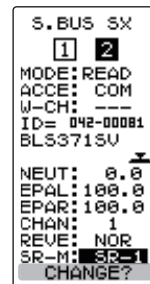

## ⚠ Caution

- Do not connect any servos that are on SR mode to a receiver via S.BUS/S.BUS2 terminal. You cannot use an SR servo in the SBUS/S.BUS2 ports, as they are not compatible with SR mode. The SR servo can be damaged if it is connected into the S.BUS/S.BUS2 ports.



1 Select the setting item by moving the (JOG) button. Set the value by (+) and (-) button.

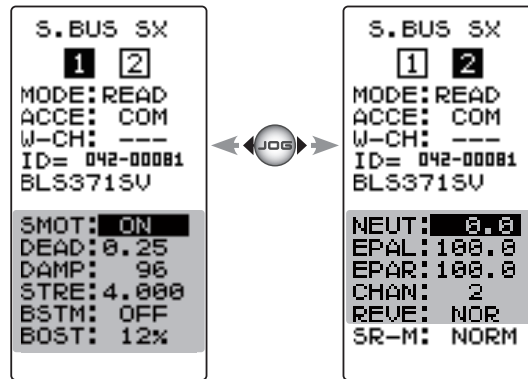

### SMOT (Smoother)

This function makes servo operation smooth. Set it according to your taste. Normally set it to "ACT". Set it to "INH" when you want especially quick operation. When the smoother function is set to "ACT" and the servo is operated, the distance up to the target position is changed in steps so movement is smooth.

### DEAD (Dead band)

The dead band angle at stopping can be specified.

[Relationship between dead band set value and servo operation]

Small - Dead band angle is small and the servo is immediately operated by a small signal change.

Large - Dead band angle is large and the servo does not operate at small signal changes.

**(Note)** If the dead band angle is too small, the servo will operate continuously and the current consumption will increase and the life of the servo will be shortened.

### DAMP (Damper)

The characteristic when the servo is stopped can be set.

When smaller than the standard value, the characteristic becomes an overshoot characteristic. If the value is larger than the standard value, the brake is applied before the stop position.

Especially, when a large load is applied, overshoot, etc. are suppressed by inertia and hunting may occur, depending on the conditions. If hunting (phenomena which cause the servo to oscillate) occurs even though the Dead Band, Stretcher, Boost and other parameters are suitable, adjust this parameter to a value larger than the initial value.

[Relationship between damper set value and servo operation]

Small - When you want to overshoot. Set so that hunting does not occur.

Large - When you want to operate so that braking is not applied. However, it will feel like the servo response has worsened.

**(Note)** If used in the hunting state, not only will the current consumption increase, but the life of the servo will also be shortened.

### STRE (Stretcher)

The servo hold characteristic can be set. The torque which attempts to return the servo to the target position when the current servo position has deviated from the target position can be adjusted.

This is used when stopping hunting, etc., but the holding characteristic changes as shown below.

[Relationship between stretcher and servo operation]

Small - Servo holding force becomes weaker.

Large - Servo holding force becomes stronger.

**(Note)** When this parameter is large, the current consumption increases.

**BSTM (Boost/-N/OFF)**

OFF: It is the boost ON at the time of low-speed operation. (In the case of usual)

ON: It is always the boost ON. (When quick operation is hope).

**BOST (Boost)**

The minimum current applied to the internal motor when starting the servo can be set. Since a small travel does not start the motor, it essentially feels like the dead band was expanded. The motor can be immediately started by adjusting the minimum current which can start the motor.

[Relationship between boost set value and servo operation]

Small - Motor reacts to a minute current and operation becomes smooth.

Large - Initial response improves and output torque increases. However, if the torque is too large, operation will become rough.

**NEUT (Neutral)**

The neutral position can be changed. When the neutral offset is large value, the servo's range of travel is restricted on one side.

**EPAL (Travel-left side)**

The maximum left travels centered about the neutral position can be set independently.

**EPAR (Travel-right side)**

The maximum right travels centered about the neutral position can be set independently.

**REVE (Reverse)**

The direction in which the servo rotates can be changed.

**SR-M (SR mode)**

It is a dedicated setting to change SR mode. See ["SR mode setting" \(Page 88\)](#). It is not changed in ["WRITE" \(page 87\)](#) of MODE of the setting item.



## ESC Link Function "MC LINK"

This is a special function which lets you set the contents of the Link software which performs Futaba electronic motor speed controller (ESC), MC960CR, MC940CR, MC950CR, MC851C, MC602C, MC402CR, etc. variable frequency and other data changes at the T4PM PULS transmitter. However, some data changes require a PC and Link software. This function is used by connecting the ESC directly to the transmitter. The T4PM PULS power switch is used at the display side. Use the various optional servo extension cords according to the distance between the transmitter and ESC. The last data read from ESC to T4PM PULS or the last data written from T4PM PULS to ESC is saved to the T4PM PULS. Since the data for each model memory can be saved, the data of up to 40 models can be saved.

-When the T4PM PULS battery voltage drops, the display switches to low battery display. Therefore, use this function when there is ample battery capacity remaining.

-Also connect the battery at the ESC side.

**-Note:** Do not read to the T4PM PULS an MC940/960CR whose speed was set to over 99990rpm by Link software side Boost Angle rpm setting.

The MC (ESC) Link function is now compatible with Acuvance ESC Xarvis and XarvisXX.

\* Please contact Acuvance for details of Xarvis / XarvisXX functions.

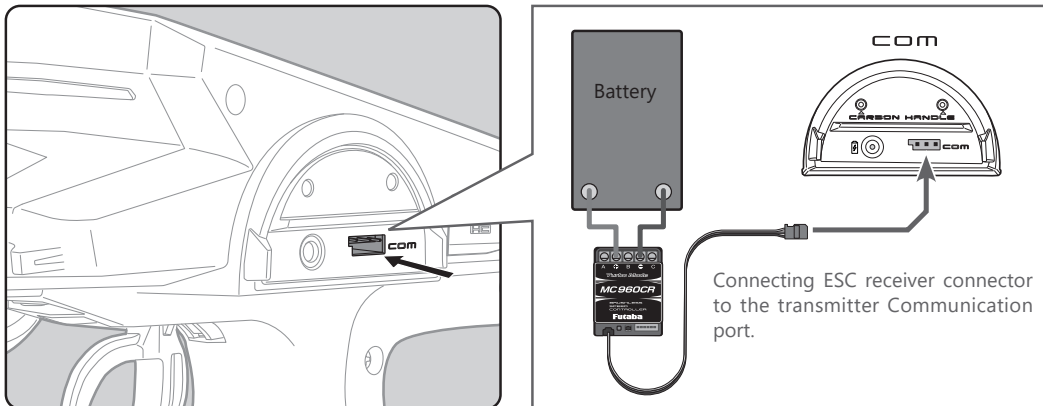

Display "MC LINK" screen using the following method:

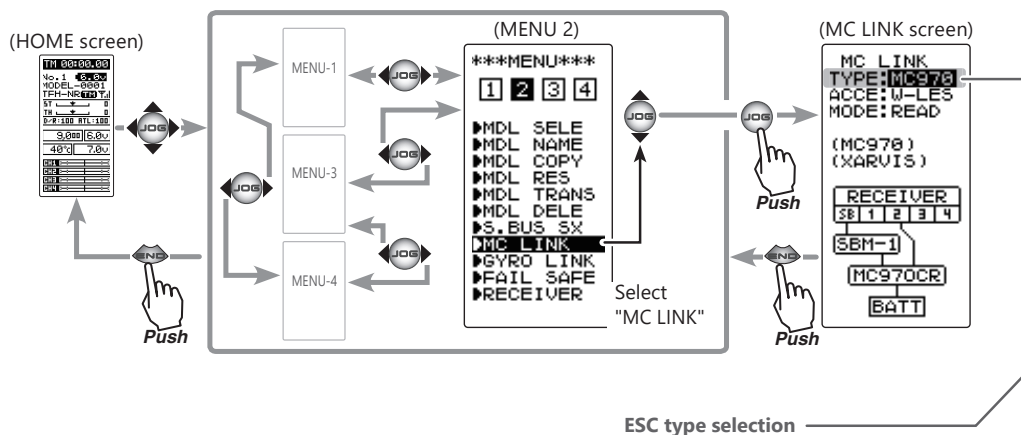

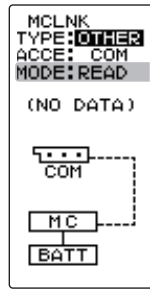

**Setup item**

- READ: ESC's data read
- WRITE: Writing the data to ESC
- RESET: Initialization
- Select with the (+) or (-) buttons.

- When using the MC970CR or Acuvance Xarvis, select "MC970CR", and when using Acuvance XarvisXX, select "XarvisXX".
- For Futaba ESC MC960CR, MC950CR, MC851C, MC602C, MC402CR, etc., please choose Other.

\* MC970CR is available only in the Japanese market. (As of August 2022)

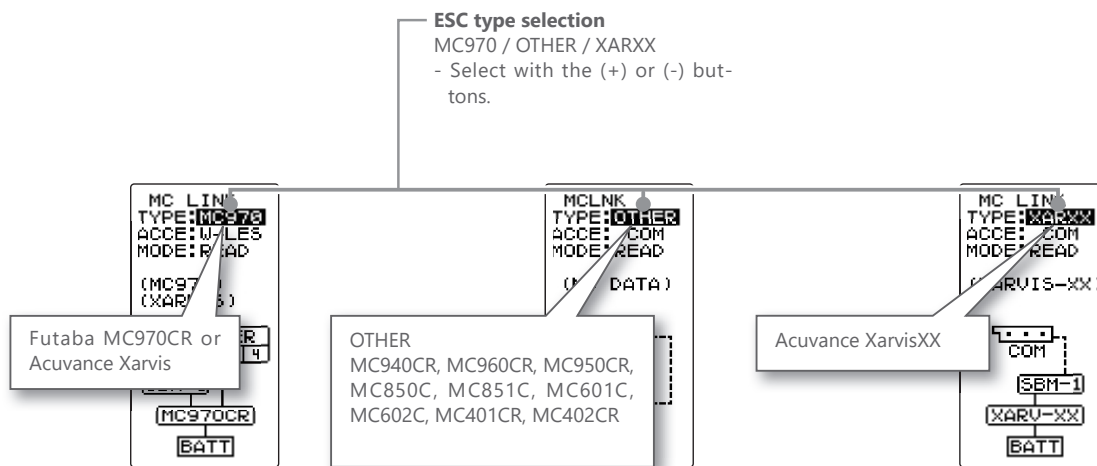

**Using the ESC Link function**

(Preparation)

-Connect the T4PM PULS and ESC in accordance with the connection diagram, and connect the battery to ESC.

**1** Display the MC LINK function screen in the above manner.

**2** (ESC read)

Execute this function to read the connected ESC type and the data currently set at the ESC. Select the setting item "MODE" by moving the (JOG) button up or down. Select "READ" by (+) or (-) button, and press the (JOG) button.

- "COMPLETE!" blinks on the screen and the ESC type and currently set contents are read.

- If "COM-ERROR" blinks on the screen, communication with the ESC is not being performed normally. Check the T4PM PULS and ESC connection and the battery connection to ESC and the ESC power switch and repeat READ.

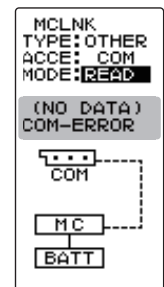
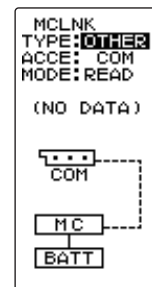

### 3 (Writing to ESC)

Execute this function to write the setting data to ESC. See pages 94 to 99 for the setting data contents.

Select the setting item "MODE" by moving the (JOG) button up or down. Select "WRITE" by (+) or (-) button, and press the (JOG) button.

- "COMPLETE!" blinks on the screen and the setting data is written to ESC.

- If "COM-ERROR" blinks on the screen, communication with the ESC is not being performed normally. Check the T4PM PULS and ESC connection and the battery connection to ESC and the ESC power switch and repeat WRITE. In addition, if (NO DATA) is displayed on the T4PM PULS screen, "WRITE" cannot be selected because there is no setting data to be written.

- Different type of ESC data cannot be written. If writing is attempted, "COM-ERROR" will link on the screen to show that the ESC type is wrong.

```
MCLNK
TYPE: OTHER
ACCE: COM
MODE: WRITE
(MC968CR)
Min: 5.0 CLM: OFF
Max: 3.0 REV: BRk
BRk: 1.5 RND: 100
DBR: 8 RND: 100
LBP: 2.8 Bk5: 0
NTB: 0 SEC: 6.0
TBN: OFF
P2 →
```

```
MCLNK
TYPE: OTHER
ACCE: COM
MODE: READ
(MC968CR)
COMPLETE!
```

```
MC(ESC)
9179: 9179
7272: COM
E-ト: 0173
(MC968CR)
COM-ERROR
```

### 4 (Initialization)

This function writes the ESC setting data set at the factory to the connected ESC and T4PM PULS. Perform "READ" before performing initialization.

Select the setting item "MODE" by moving the (JOG) button up or down. Select "RESET" by (+) or (-) button, and press the (JOG) button.

- "COMPLETE!" blinks on the screen and the initial data is written to the ESC. If "COM-ERROR" blinks, communication with the ESC was not performed normally. Check the T4PM PULS and ESC connection and the battery connection to ESC and the ESC power switch, and repeat RESET. In addition, when (NO DATA) is displayed on the T4PM PULS screen "RESET" cannot be selected because there is no write initial data.

```
MCLNK
TYPE: OTHER
ACCE: COM
MODE: RESET
(MC968CR)
```

```
MCLNK
TYPE: OTHER
ACCE: COM
MODE: RESET
(MC968CR)
COMPLETE!
```

```
MCLNK
TYPE: OTHER
ACCE: COM
MODE: RESET
(MC968CR)
COM-ERROR
```



- 1 Select the setting item by moving the (JOG) button up or down.  
Set the value by (+) and (-) button.

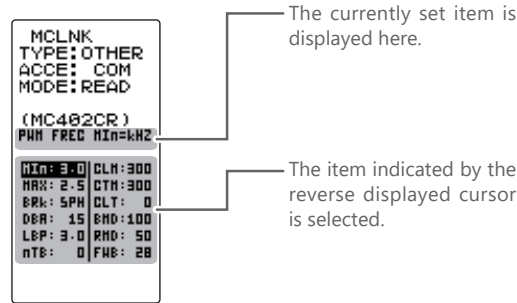

**Setup item selection**  
- Select by the (JOG) button.

**Adjustment buttons**  
- Use the (+) and (-) buttons to make adjustments.  
- Return to the initial value by pressing the (+) and (-) buttons simultaneously (approx. 1 sec).

**Setup item**

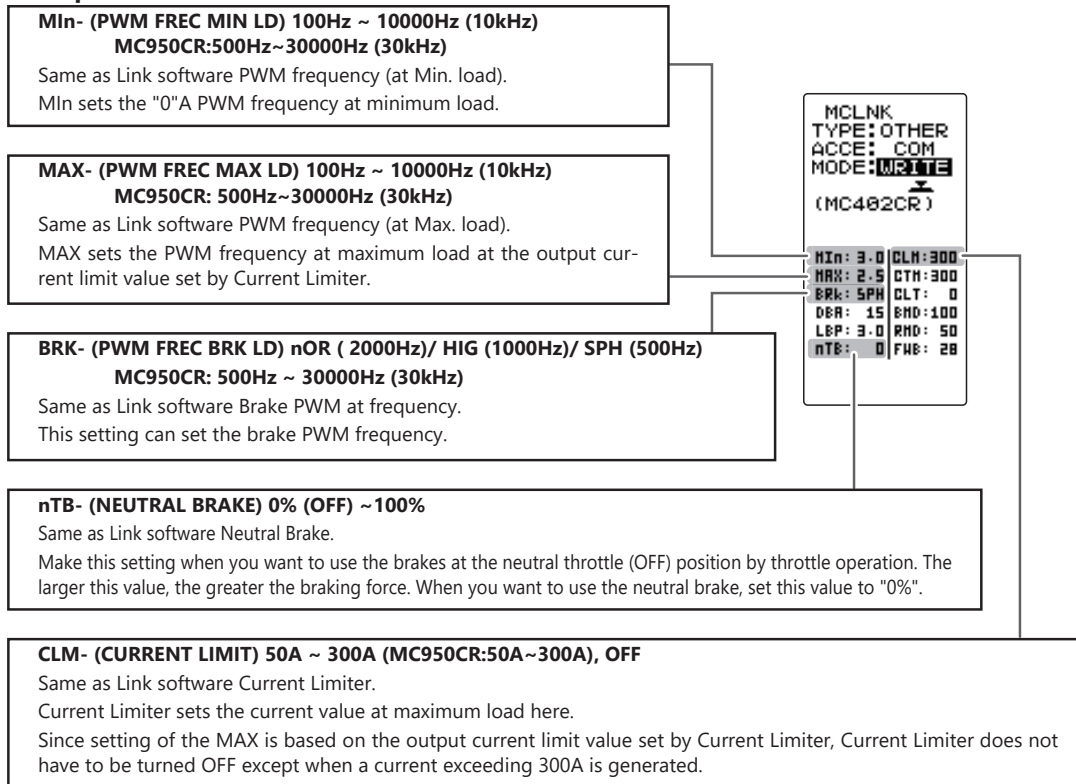

"Min", which sets the frequency when the load is small, is set to the high frequency side (large value) when extension is desired after straightaways and curves.

"MAX", which sets the frequency when the load is large, is set to the high frequency side (large value) when you want to suppress the rise from low speed and when motor heating and commutator roughness are sensed. When the rise from low speed is poor, and becomes bad even when "MAX" is set to the low frequency side, use the log data to check if there was a momentary voltage drop. When you want to suppress the overall power, lengthen the run time, and otherwise improve efficiency, set both "MAX" and "Min" to the high frequency side. When you want to set a fixed PWM frequency at full range regardless of the load current, set PWM frequency (at Max. load) and PWM frequency (at Min. load) to the same value.

**LBP- (LOW BATTERY VOLT) 2.5V ~ 6V  
2.5V ~ 7.5V for MC950CR**  
Same as Link software Low Bat Protection.  
This setting cuts off the output to the motor when the running battery voltage drops to the set voltage to prevent the receiver from stopping operation when the supply of voltage to the receiver becomes insufficient while running due to a drop in the power supply voltage. When the power supply voltage recovers, power is supplied to the motor once more.

**DBA- (DEAD BAND)  $\pm 2\mu s \sim \pm 50\mu s$**   
Same as Link software Dead Band.  
This sets the range (neutral point range) over which the ESC does not respond to transmitter throttle operation.  
The larger the set value, the wider this range.

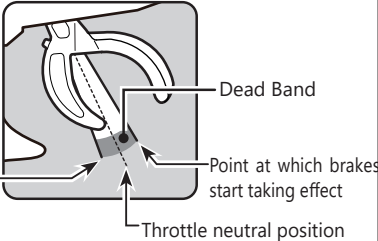

```

MC_LNK
TYP: OTHER
ACC: COM
MOD: WRITE
(MC482CR)

MIN: 3.0 | CLN: 300
MAX: 2.5 | CTN: 300
BRK: 5PH | CLT: 0
DBA: 15 | RND: 100
LBP: 3.0 | RMD: 50
NTE: 0 | FNB: 28
  
```

**CTM- (C.L. TIME LIMIT) 50A~300A / CLT -(C.L. TIMER) 0sec (OFF) ~ 240sec (except MC950CR)**  
Same as Link software Current Limiter (Time Limit) / Current Limit timer.  
The output current can be limited up to the set time lapse from the start of running. This is effective in preventing the motor from outputting wasted energy when the voltage is high immediately after the power battery was recharged.  
- "CTM" (Time Limit) sets the maximum output current within the time the output current is limited.  
- "CLT" sets the time the output current is limited. This function is disabled when set to "0" sec.  
Since the Current Limit Timer starts when the throttle is operated to the forward side and current is output to the motor, this function begins to operate when the motor is run during trim adjustment, etc.

**FWB- (FORWARD BOOST) 0 ~ 100 (except MC850C)**  
Same as Link software Forward Boost.  
Operation near the throttle trigger (stick) neutral position becomes a sharp rise.

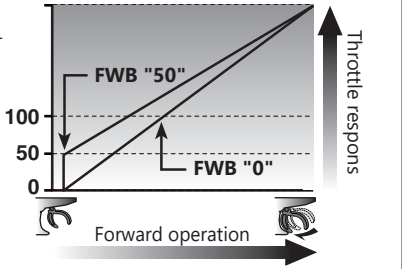

**BMD- (BRAKE MAX DUTY) 0% ~ 100%**  
Same as Link software Brake Max. Duty.  
This setting can set the braking force between the neutral point and Max brake point. The larger this value, the greater the braking force. When set to "0%", the brakes are not effective.  
**RMD- (REVERSE MAX DUTY) w/back only 0% ~ 100%**  
Same as Link software Reverse Max. Duty.  
This setting can set the reverse power between the neutral point and Max reverse point. The larger this value, the greater the reverse power. When set to "0%", the reverses are not effective.

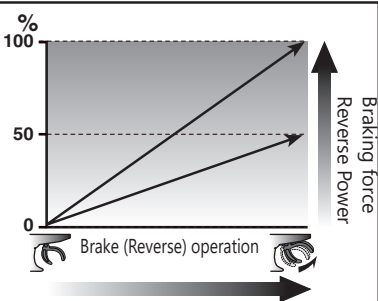

**MC950CR only setup item**

```

MIN: 5.0 | CLN: OFF
MAX: 3.0 | REV: BRK
BRK: 1.5 | LA: 0
DBA: 0 | RND: 100
LBP: 2.5 | RMD: 100
NTE: 2 | FNB: 6
  
```

**REV- (REV CANCEL) BRK /REV** Same as Link software Reverse Cancel.  
When set to BRK, reverse operation is not performed.  
**LA- (LEAD ANGLE) 0 ~ 1500** Same as Link software Lead Angle.  
The lead angle of the motor can be set at the MC950CR side. However, we recommend that it normally be set to "0". Since this setting is premised on setting by referring to the speed log by the Link software, independent use of the MC LINK function of the T4PM PULS is recommended.

- 1 Select the setting item by the (JOG) button up or down.  
Set the value by (+) and (-) button.  
Operate the following (JOG) button and switch between Page 1 and Page 2 of the setup screen.

**Setup item selection**  
- Select by the (JOG) button.

**Adjustment buttons**  
- Use the (+) and (-) buttons to make adjustments.  
- Return to the initial value by pressing the (+) and (-) buttons simultaneously (approx. 1 sec).

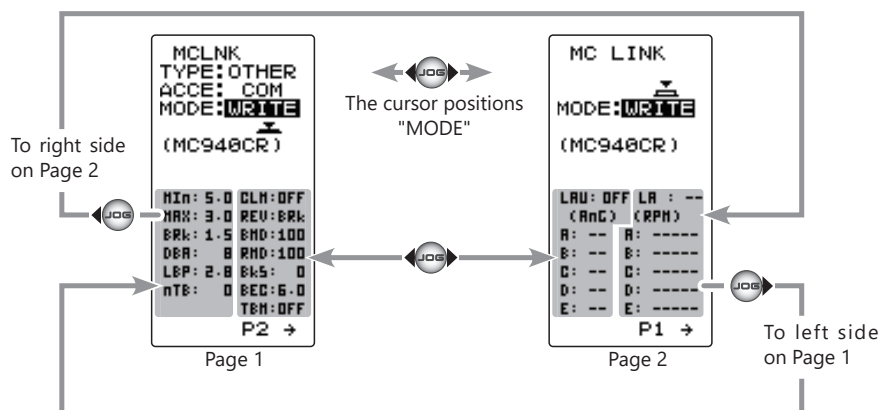

**Setup item**

**Min- (PWM FREQ MIN LD) 1kHz (1000Hz) ~ 30kHz (30000Hz)**  
Same as Link software PWM frequency (at Min. load).  
Min sets the "0"A PWM frequency at minimum load.

**MAX- (PWM FREQ MAX LD) 1kHz (1000Hz) ~ 30kHz (30000Hz)**  
Same as Link software PWM frequency (at Max. load).  
MAX sets the PWM frequency at maximum load at the output current limit value set by Current Limiter.

**BRK- (PWM FREQ BRK LD) 1kHz (1000Hz) ~ 30kHz (30000Hz)**  
Same as Link software Brake PWM at frequency.  
This setting can set the brake PWM frequency.

**nTB- (NEUTRAL BRAKE) 0% (OFF) ~ 100%**  
Same as Link software Neutral Brake.  
Make this setting when you want to use the brakes at the neutral throttle (OFF) position by throttle operation. The larger this value, the greater the braking force. When you want to use the neutral brake, set this value to "0%".

**CLM- (CURRENT LIMIT) 50A ~ 500A**  
Same as Link software Current Limiter.  
Current Limiter sets the current value at maximum load here.  
Since setting of the MAX is based on the output current limit value set by Current Limiter, Current Limiter does not have to be turned OFF except when a current exceeding 300A is generated.

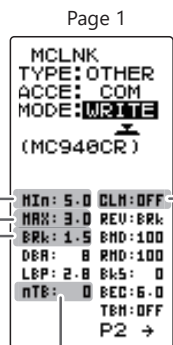



"**Min**", which sets the frequency when the load is small, is set to the high frequency side (large value) when extension is desired after straightaways and curves.

"**MAX**", which sets the frequency when the load is large, is set to the high frequency side (large value) when you want to suppress the rise from low speed and when motor heating and commutator roughness are sensed.

When the rise from low speed is poor, and becomes bad even when "**MAX**" is set to the low frequency side, use the log data to check if there was a momentary voltage drop. When you want to suppress the overall power, lengthen the run time, and otherwise improve efficiency, set both "**MAX**" and "**Min**" to the high frequency side. When you want to set a fixed PWM frequency at full range regardless of the load current, set PWM frequency (at Max. load) and PWM frequency (at Min. load) to the same value.

**LBP- (LOW BATTERY VOLT) 2.5V ~ 7.5V**

Same as Link software Low Bat Protection.

This setting cuts off the output to the motor when the running battery voltage drops to the set voltage to prevent the receiver from stopping operation when the supply of voltage to the receiver becomes insufficient while running due to a drop in the power supply voltage. When the power supply voltage recovers, power is supplied to the motor once more.

```

MCLNK
TYPE: OTHER
ACCE: COM
MODE: WRITE
(MC948CR)

Min: 5.0 CLN: OFF
Max: 3.0 REV: BRK
Brk: 1.5 RMD: 100
DBA: 8 RND: 100
LBP: 2.8 Bk5: 0
nTB: 0 BEC: 6.0
TBM: OFF
P2 →
    
```

Page1

**DBA- (DEAD BAND) ±2µs ~ ±50µs**

Same as Link software Dead Band.

This sets the range (neutral point range) over which the ESC does not respond to transmitter throttle operation. The larger the set value, the wider this range.

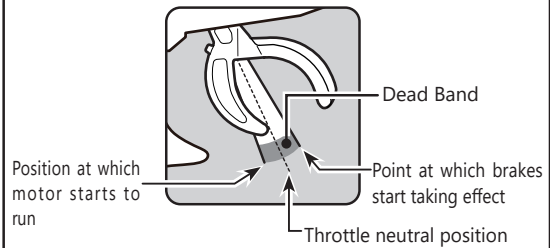

**REV- (REV CANCEL) Brk / REV**

Same as Link software Reverse Cancel.

When set to BRk, reverse operation is not performed.

**BMD- (BRAKE MAX DUTY) 0% ~ 100%**

Same as Link software Brake Max. Duty.

This setting can set the braking force between the neutral point and Max brake point. The larger this value, the greater the braking force. When set to "0%", the brakes are not effective.

**RMD- (REVERSE MAX DUTY) w/back only 0% ~ 100%**

Same as Link software Reverse Max. Duty.

This setting can set the reverse power between the neutral point and Max reverse point. The larger this value, the greater the reverse power. When set to "0%", the reverses are not effective.

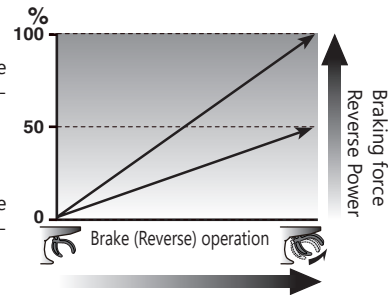

```

MCLNK
TYPE: OTHER
ACCE: COM
MODE: WRITE
(MC948CR)

Min: 5.0 CLN: OFF
Max: 3.0 REV: BRK
Brk: 1.5 RMD: 100
DBA: 8 RND: 100
LBP: 2.8 Bk5: 0
nTB: 0 BEC: 6.0
TBM: OFF
P2 →
    
```

Page 1

**BKS- (BRAKE SLOPE) 0~300 (Only when used TBM-LEV2)**

Same as Link software Brake Slope.

This function adjusts the braking effect when the throttle was returned (throttle off). It cancels operation like that called engine brake of actual vehicles.

**BEC- (BEC VOLT) 6.0V /7.4V**

Same as Link software BEC Volt.

The receiver BEC voltage can be selected from 6.0V and 7.4V. Match the voltage to the rating of the servo connected to the same receiver. This BEC voltage cannot output a voltage higher than the input voltage.

```

MCLNK
TYPE: OTHER
ACCE: COM
MODE: WRITE
(MC948CR)

Min: 5.0 CLM: OFF
MAX: 3.0 REV: 8Rk
BRk: 1.5 BMD: 100
DBA: 8 BMD: 100
L&P: 2.8 Bk5: 0
nTB: 0 BEC: 6.0
TBM: OFF
P2 →

```

Page 1

**TBM- (TURBO MODE) OFF / LV1 / LV2**

Same as Link software Turbo Mode.

This function sets the turbo mode. More power can be displayed by using the turbo mode. Depending on the setting, the motor and ESC may be damaged so make this setting carefully.

(Note) When LAU (LEAD ANGLE USE) is off, lead angle setting will not operate even if set to LEV1 or LEV2. (Turbo mode disabled, TBM=OFF)

**OFF mode: (No Lead Angle mode) Lead angle - No**

When used in races in which the lead angle setting function is inhibited by ESC, set to this mode. The lead angle function is disabled the same as if LAU (LEAD ANGLE USE) was turned off.

When the lead angle function was disabled by the method described above, the MC960CR shows that the lead angle function is off by blinking a blue LED at an ON 0.1 second, OFF 0.9 second cycle at the neutral point.

**LV1 turbo mode: (Lead Angle mode) Lead angle – Yes**

The output can be increased by setting a lead angle.

Depending on the set value, the motor may be damaged so increase the lead angle value in steps from a small value while observing the conditions.

Turn on LAU (Lead Angle Use) and adjust the lead angle by LA-(LEAD ANGLE) and A, B, C, D, E BA-(A, B, C, D, E BOOST ANGLE) value.

**LV2 power mode: (Power Mode) Lead angle – Yes**

Displays still more power than a turbo.

However, since even a motor applies a large load on the ESC, make the lead angle larger in steps from a small value while observing the conditions.

Turn on LAU (LEAD ANGLE USE) and adjust the lead angle by LA-(LEAD ANGLE) and A, B, C, D, E BA-(A, B, C, D, E BOOST ANGLE) value.

When "LAU" (LEAD ANGLE USE) is turned on, "LA" (LEAD ANGLE) is the lead angle that can be set. In addition, the "BOOST ANGLE" and "BOOST ANGLE RPM" can be set.

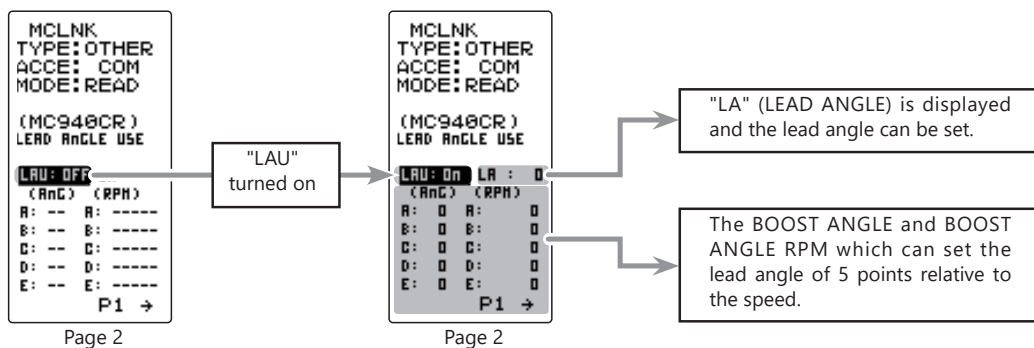



Page 2

**LAU -(LEAD ANGLE USE) ON /OFF**

Same as Link software Lead Angle Use.

This function is effective when TBM (Turbo Mode) is LEV1 or LEV2 and sets whether or not lead angle is used. This setting has priority over the TURBO MODE setting. When used in races in which the lead angle function is inhibited by the ESC, set this function to OFF.

- OFF : Lead angle function not used.
- ON : Lead angle used.

**LA- (LEAD ANGLE) 0~59deg**

Same as Link software Lead Angle.

When LAU (LEAD ANGLE USE) is turned on the motor lead angle can be set at the MC960CR. The lead angle can be set up to 59 degrees in 1 degree increments.

**A,B,C,D,E BA- (A,B,C,D,E BOOST ANGLE) 0 ~ 59deg**

Same as Link software Boost Angle.

**A,B,C,D,E RPM-(A,B,C,D,E BOOST ANGLE RPM) 0 ~ 99990rpm**

Same as Link software Boost Angle rpm.

When LAU (LEAD ANGLE USE) is turned on the lead angle versus motor speed of the 5 points A to E can be set. The lead angle can be set up to 59 degrees in 1 degree increments.

**Note:** Do not read to the T4PM PULS an MC940 / 960CR whose speed was set to over 99990rpm by Link software side Boost Angle rpm setting.

The LA-(LEAD ANGLE) and A, B, C, D, E BA- (A, B, C, D, E BOOST ANGLE) relationship are shown on the graphs below. Graph [A] shows the relationship when the same value is set at points A, B, C, D, E BA-(A, B, C, D, E BOOST ANGLE) of [A] and [B] and the LA-(LEAD ANGLE) is set to "0". Graph [B] shows the relationship when a value other than "0" is set at LA-(LEAD ANGLE). As shown in the graphs, [B] is added to the A, B, C, D, E BA-(A, B, C, D, E BOOST ANGLE) set lead angle and [A] is added to the LA-(LEAD ANGLE) set lead angle. For example, if "3" is set at ABA and LA of [B] is set to "2", the actual ABA becomes 3+2=5 (deg). Since LA of [A] is "0", the actual ABA also becomes 3+0=3 (deg).

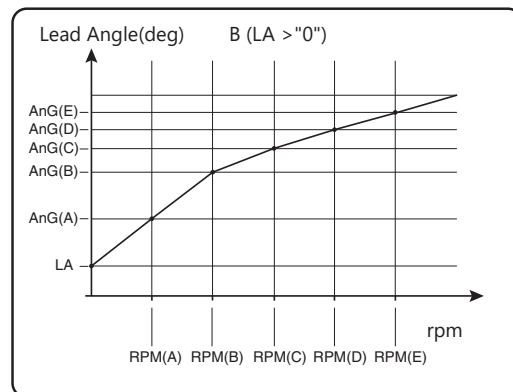
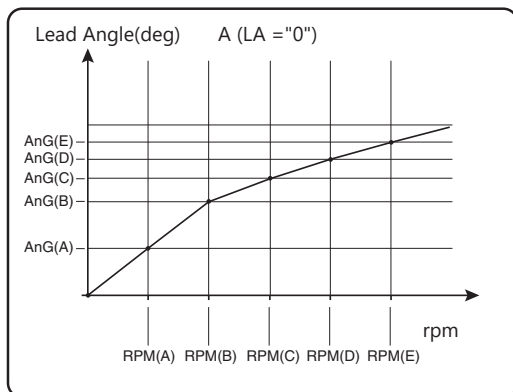

When using in races in which the lead angle setting function is inhibited by the ESC, set LAU (LEAD ANGLE USE) to OFF. The LAU setting has priority over TBM-(TURBO MODE). If LAU is set to "OFF", the lead angle setting function can be turned off even if TBM is set to "LV1" or "LV2".

The MC940,960CR shows that the lead angle setting function is OFF ("0" timing) by blinking a LED.

# Gyro Link Function "GYRO LINK"

The Gyro Link is a function that allows you to set the parameters of the car gyro wirelessly from the transmitter.

\* A gyro compatible with the wireless setting: GYD550 (As of August 2022)

-Up to five presets can be switched while driving. (Gyro data switching function)

-The S.BUS servo data can be set wirelessly from the transmitter via the gyro.

\* A receiver compatible with the wireless setting function is required. (As of August 2022, R334SBS / R334SBS-E is compatible with wireless setting. Please update the previous receiver to version 4.0 or later.)

\* While using Gyro Link wireless (SBUS connection) SBUS servo adjustment will not function.

-To be able to control gyro gain, etc. from the transmitter, it is necessary to enable the gyro mixing function of the transmitter.

Display "GYRO LINK" screen using the following method:

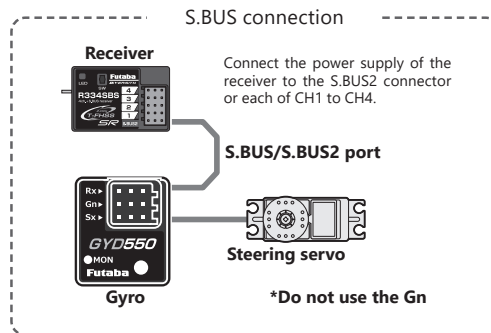
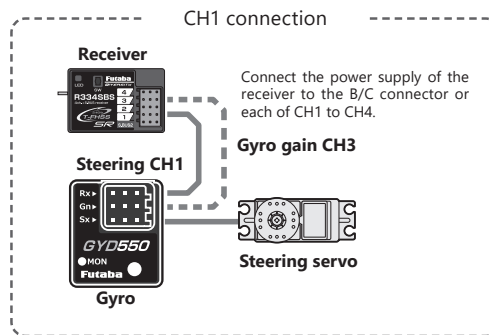
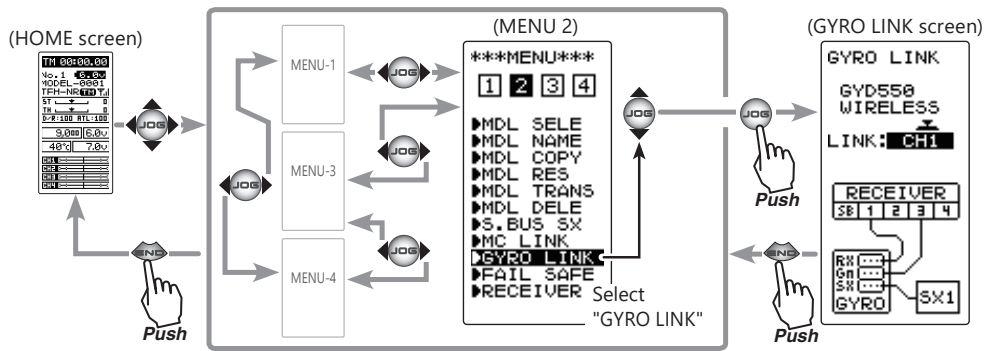

## Using the Gyro Link function

(Preparation)

- Connect the receiver and gyro according to the connection diagram below.

\* The connection diagram is a reference diagram for selecting the gyro link connection method. Please read the gyro instructions for details or cautions.

- 1 Turn on the power switch of the transmitter to display the Gyro Link screen. Turn on the receiver power switch.

- 2 (Gyro read)

Execute this function to read the data currently set at the gyro. Select the setting item "LINK" by moving the (JOG) button up or down. Select the connection type by (+) or (-) button, and press the (JOG) button. A beep sounds and the gyro data is read.

- If "COM-ERROR" blinks on the screen, communication with the gyro is not being performed normally. Check the connection between the receiver, gyro, and battery, turn on the power of the transmitter and receiver, and repeat READ.

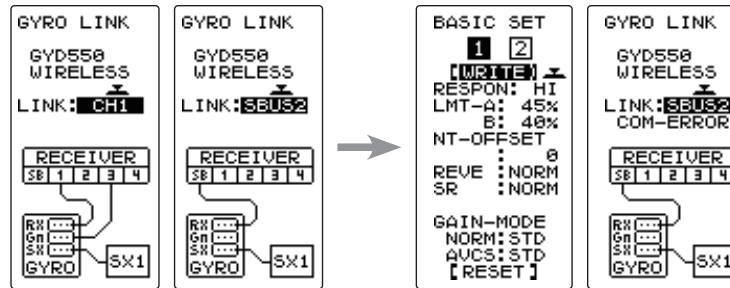

- 3 (Writing to gyro)

Execute this function to write the setting data to the gyro.

Select the setting item "WRITE" by moving the (JOG) button up or down, and press the (JOG) button. A beep sounds and the gyro data is written.

If "COM-ERROR" blinks on the screen, communication with the gyro is not being performed normally. Check the connection between the receiver, gyro, and battery, turn on the power of the transmitter and receiver, and repeat WRITE.

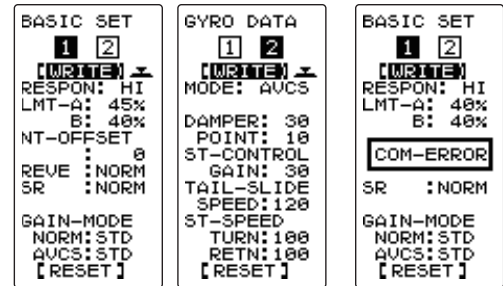

- 4 (Initialization)

This function writes the gyro setting data set at the factory to the connected gyro.

Select the setting item "RESET" by moving the (JOG) button up or down, and press the (JOG) button. A beep sounds and the gyro data is initialization.

- If "COM-ERROR" blinks on the screen, communication with the gyro is not being performed normally. Check the connection between the receiver, gyro, and battery, turn on the power of the transmitter and receiver, and repeat RESET.

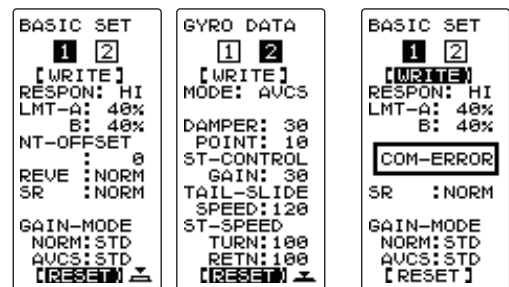

Select the setting item by moving the (JOG) button up or down. Set the value by (+) and (-) button.

Example: (BASIC SET screen)

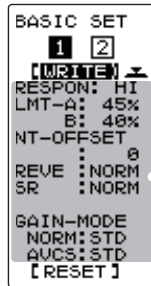

**Setup item selection**

Select by the (JOG) button.  
The item indicated by the reverse displayed cursor is selected.

**Set button**

- Use the (+) and (-) buttons to make adjustments.
- Return to the initial value by pressing the (+) and (-) buttons simultaneously (approx. 1 sec).

(BASIC SET screen)

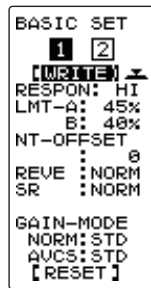

(GYRO DATA screen)

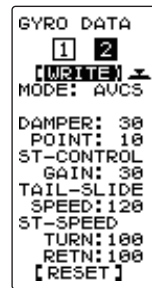

※ **BASIC SET**

\* In the T-FHSS SR mode, the servo position will not adjust until "WRITE", even if the "LMT" and "NT-OFFSET" functions are adjusted with (+) and (-) buttons .

**-RESPON (Response mode)**

Gyro sensor response setting.

\* LOW → MID → HI speeds up response.

\* In high mode, using the dead band angle is too small, the servo will work continuously, but there is no problem in running. However, if strong the servo will work continuously occurs, set to middle or low mode.

**-LMT A/B (Limit A/B)**

Adjustment function of maximum steering angle.

\* Operate the steering and adjust the left and right separately so that the maximum steering angle is obtained as long as the tires do not interfere with the arms.

\* If the adjustment value of the limit is small (the maximum steering angle is not adjusted), it becomes easier to spin.

\* During limit adjustment, the steering angle is amplified by 1.5 times, but this is not a malfunction. However, perform drive after completing the limit adjustment.

**-NT-OFFSET (Neutral offset)**

Neutral adjustment function of the steering servo.

\* Do not use transmitter trim and sub trim. Make the neutral setting with a gyro.

**-REV (Reverse)**

Gyro control direction setting.

\* If the car is turned to the left by hand steering goes out on the right.

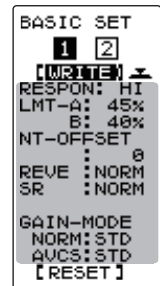

### -GAIN-MODE (Gain mode)

Gyro internal control gain switching.

\* High gain is 1.5 times more sensitive than standard gain.

\* Normally set to standard.

Set to high gain if increasing the sensitivity setting of the transmitter to the maximum value is not enough.

### -SR (SR mode setting)

Set to SR mode.

\* Set the SR compatible servo to SR only when using SR mode.

## ※ GYRO DATA

The data can be set independently in each gyro operation mode (AVCS / NORMAL).

### -AVCS and normal mode change button

The AVCS / NORMAL modes setting.

The gyro has 2 operating modes: NORMAL mode and AVCS mode.

In the AVCS mode, gyro control is firmer.

\* The feel of operation is different, choose your favorite mode.

\* NORMAL: The driver needs to perform counter-steer → Operation opposite to the turn direction.

\* AVCS: The gyro performs countersteer → Steer in the turn direction.



### -DAMPER (Damper)

Hunting suppression

The higher the value, the stronger the hunting suppression. However, it will feel like the servo response has worsened.

### -DAMPER POINT (Damper point)

Adjust the servo response due to the effect of the damper against the gyro effect.

\* The smaller the value, the stronger the influence of the Damper and the slower the servo speed.

\* The higher the value, the slower the Damper will operate and the better the response, but the more likely it is that hunting will occur.

### -ST-CONTROL GAIN (Steering control gain)

Adjustment of intervention ratio of steering operation to gyro control.

When the numerical value is increased, the steering operation of the driver is largely reflected.

\* The steering response feels fast.

### -TAIL- SLIDE SPEED (Tail slide speed)

Adjust the speed of the tail slide (shake the tail) when driving.

\* Decreasing the numerical value decreases the speed of the tail slide, and increasing the numerical value increases the speed.

\* Effective for adjusting the tail slide amount during steering operation.

### -ST-SPEED (Steering speed)

The function to adjust servo speed for steering operation (same the function as servo speed of the transmitter).

\* The smaller the value, the slower the servo speed.



# Select TRIM Dial Function "TRIM DIAL"

Selection of the function to be performed by trims and dial (DT1, DT2, DT3, DT4, DT5, DL1).

- The functions that can be assigned to dial and digital trim are listed on the next page.
- The dial and digital trim step amount can be adjusted (The relationship between set value and step amount is shown in the table on the next page).
- The operation direction can be reversed (NOR/REV).

Display "TRIM DIAL" screen using the following method:

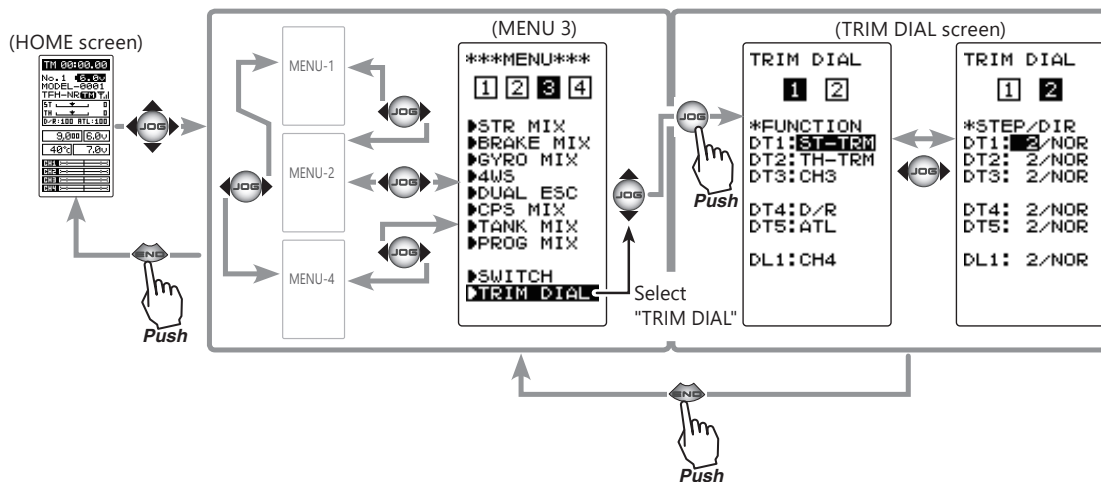

## Function select trim/dial setting

### 1 (Setting trim/dial selection)

Select the trim or dial you want to set by moving the (JOG) button up or down.

### 2 (Function setting)

Select the function with the (+) or (-) button.

- Refer to the list on the next page for the abbreviations of the functions.

(Step amount setting)

Select the step amount you want to set by moving the (JOG) button up or down. Use the (+) or (-) button to set the step amount.

- Refer to the next page for the relationship between set value and step amount.

(Changing the direction of operation)

Select the direction of operation you want to set by moving the (JOG) button up or down. Use the (+) or (-) button to trim/dial the direction.

### Adjustment buttons

- Use the (+) and (-) buttons to make adjustments.
- Return to the initial value by pressing the (+) and (-) buttons simultaneously (approx. 1 sec).

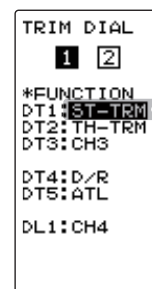

\*Function selection

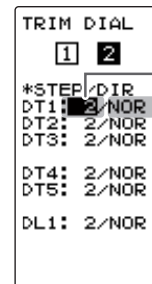

\*Step amount setting

\*Direction of operation setting

### 3 When finished with the setting, return to the MENU screen by pressing the (END) button.



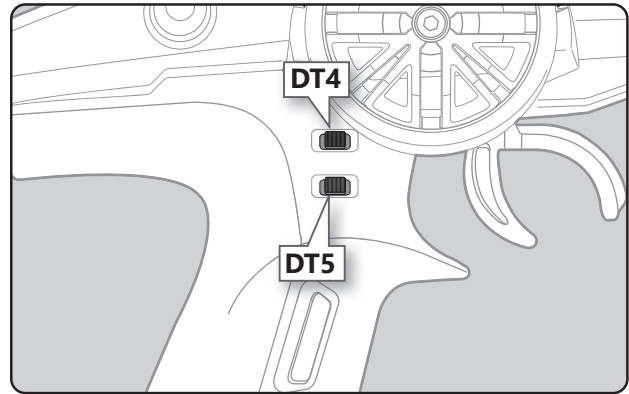
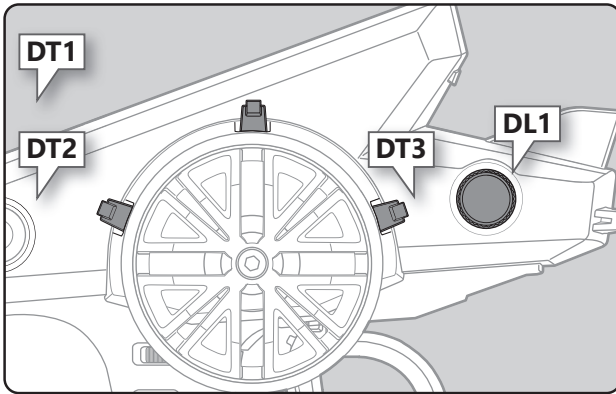

Set table functions (DL1, DT1/DT2/DT3/DT4/DT5)	
Abbreviation used on setup screen	Function name, etc
D/R	Dual rate function
ATL	ATL function
EXP-ST	Steering EXP
EXP-FW	Throttle EXP (Forward side)
EXP-BK	Throttle EXP (Brake side)
SPD-TN	Steering speed (Turn side)
SPD-RN	Steering speed (Return side)
ABS.PS	A.B.S. function (Return amount)
ABS.DL	A.B.S. function (Delay)
CYCLE	A.B.S. function (Cycle speed)
ACC-FW	Throttle acceleration (Forward side)
ACC-BK	Throttle acceleration (Brake side)
ACC-B3	Throttle acceleration (3rd channel Brake side/Brake MIX-ACT)
ACC-B4	Throttle acceleration (4th channel Brake side/Brake MIX-ACT)
TSP-TN	Throttle speed (Turn side)
TSP-RN	Throttle speed (Return side)
ST-TRM	Steering trim
TH-TRM	Throttle trim
CH3	Channel 3
CH4	Channel 4
SUBTR1	Sub trim (CH1)
SUBTR2	Sub trim (CH2)
SUBTR3	Sub trim (CH3)
SUBTR4	Sub trim (CH4)
IDLE	Idle up function
ESC-RT	Dual ESC mixing (4ch ESC rate)
TH-OFF	Throttle off (engine cut)
PMX-1A	Program 1 mixing (RGHT/BRAK/DOWN sides)
PMX-1B	Program 1 mixing (LEFT/FWRD/UP sides)
PMX-2A	Program 2 mixing (RGHT/BRAK/DOWN sides)
PMX-2B	Program 2 mixing (LEFT/FWRD/UP sides)
BK3-RT	Brake mixing (3ch brake rate)
BK4-RT	Brake mixing (4th brake rate)
4WS-RT	4WS mixing (3ch steering rate)
ESC-MD	Dual ESC mixing (Drive mode select)
GYRO	Gyro mixing (Gain rate)
ACKMAN	Ackermann mixing (ackermann rate)
TRC.PS	Traction function (Return amount)
TRC.DL	Traction function (Delay)
TRC.CY	Traction function (Cycle speed)
M.ST.F	Steering force adjustment for MINI-Z FHSS
M.GAIN	Gyro gain adjustment of MINI-Z FHSS
OFF	Not used

### Relationship between set value and step amount

(Setting range: 1~10, 20, 30, 40, 50, 100, 2P)

-Steering trim/throttle trim

When set to the minimum "1", the total trim operating width is 200 clicks. For "100", the total operating width is 2 clicks and for 2P, the total operating width is 1 click.

-Rate, etc. setting

This is the % value which is operated by 1 click relative to the set value of each rate. Since the total operating width of functions having a rate of -100~0~+100 is 200%, when set to "100", the total operating width is 2 clicks. Since the total operating width of functions with a 0~100 rate is 100%, "100" and 2P are operated by 1 click.

-Channel 3/4

When set to the minimum "1", the total operating width of channel 3 is 200 clicks. For "100", the total operating width is 2 clicks and 2P is operated by 1 click.

# Select Switch Function "SWITCH"

Selection of the function to be performed by the switches (SW1, SW2).

- SW1 ON/OFF direction can be reversed (NOR/REV).
- SW2 alternate operation (operation which switches between ON and OFF each time the switch is pressed) is possible.

NOR (Normal) -ON only while pressed, OFF when released.

ALT (Alternate) -Switched between ON and OFF each time pressed.

Display "SWITCH" screen using the following method:

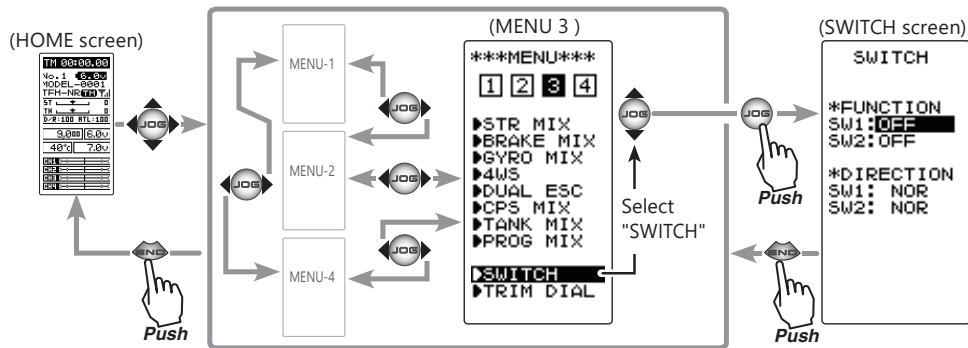

## Function select switch setting

**1** (Setting switch selection)  
Select the switch you want to set by moving the (JOG) button up or down.

**2** (Function setting)  
Select the function with the (+) or (-) button.  
- Refer to the list on the next page for the abbreviations of the functions.

(Changing the SW1 operation direction)  
Select "DIRECTION" of "SW1" by moving the (JOG) button up or down. Select REV or NOR with the (+) or (-) button.

(Changing the SW2 operation system)  
Select "DIRECTION" of "SW2" by moving the (JOG) button up or down. Select ALT or NOR with the (+) or (-) button.

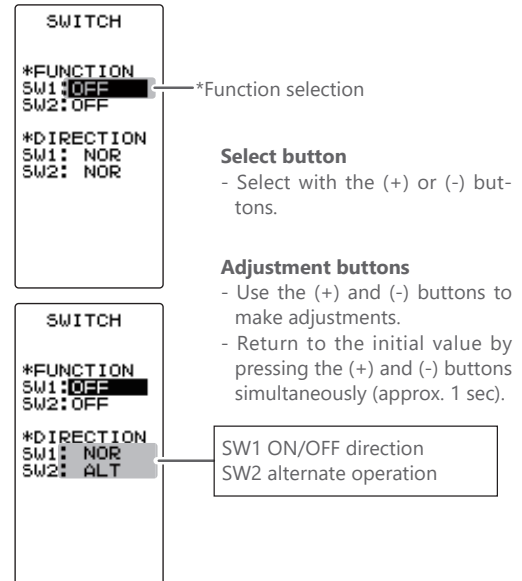

**3** When finished with the setting, return to the MENU screen by pressing the (END) button.

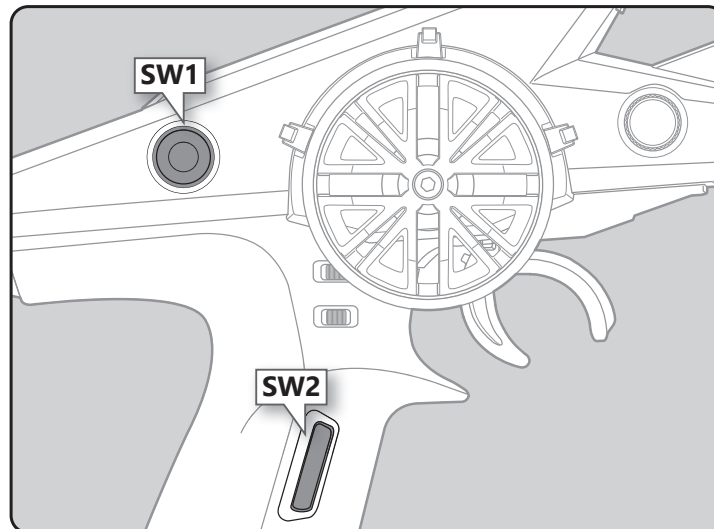

Set table functions (SW1)	
Abbreviation used on setup screen	Function name, etc
NT-BRK	Neutral brake function ON/OFF
ABS	A.B.S function ON/OFF
IDLE	Idle up function ON/OFF
PMIX-1	Program mixing 1 function ON/OFF
PMIX-2	Program mixing 2 function ON/OFF
TH-OFF	Throttle off (engine cut) function ON/OFF
CH3	Channel 3
CH4	Channel 4
TRAC	Traction function ON/OFF
GYRO	Switching GYRO mode
OFF	Not used

Set table functions (SW2)	
Abbreviation used on setup screen	Function name, etc
NT-BRK	Neutral brake function ON/OFF
ABS	A.B.S function ON/OFF
IDLE	Idle up function ON/OFF
PMIX-1	Program mixing 1 function ON/OFF
PMIX-2	Program mixing 2 function ON/OFF
TH-OFF	Throttle off (engine cut) function ON/OFF
CH3	Channel 3
CH4	Channel 4
TRAC	Traction function ON/OFF
GYRO	Switching GYRO mode
4WS	4WS mixing type select
TIMER	Timer function start/stop
LOGGER	Telemetry log start/stop
OFF	Not used

This mixing function uses 2 servos to individually control the left and right steering. Left and right steering can be set independently so smooth cornering is possible.

The right side steering servo or the left side steering servo connects to receiver CH1 and the other side connects to receiver CH4. The channel to which the left and right servo connects is not specified. After the left and right servos are adjusted individually, Ackerman can also be adjusted by Ackerman rate.

### Setting Special mixings

When the 4th CH is set to ACT by [BRAKE MIX \(page 110\)](#), or when [DUAL ESC \(page 116\)](#) and [CPS MIX \(page 118\)](#) are used, this steering mixing function cannot be used.

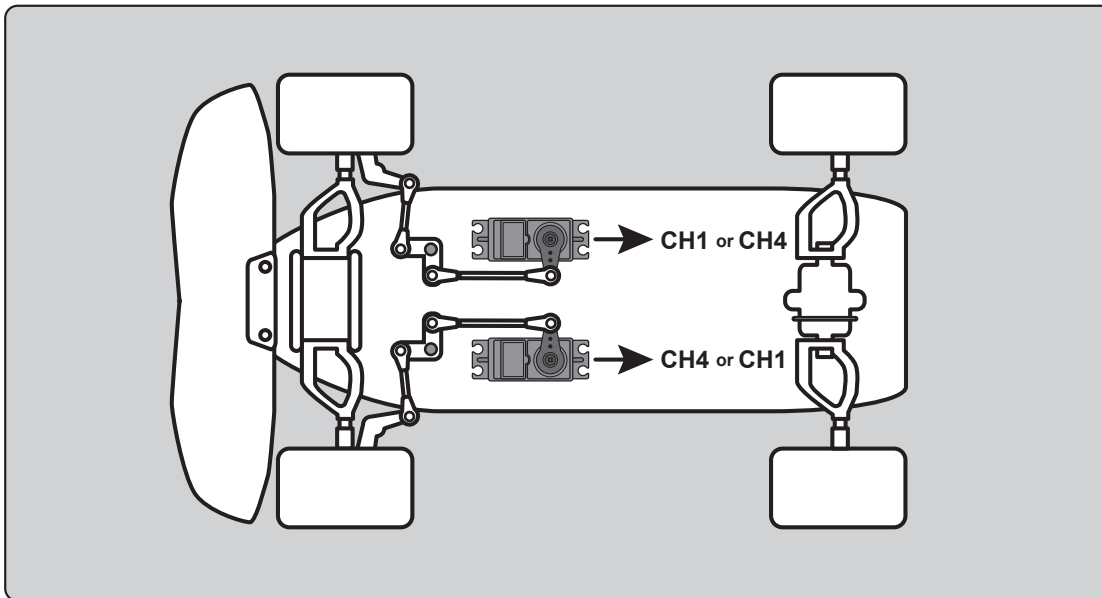

Display "STR MIX" screen using the following method:

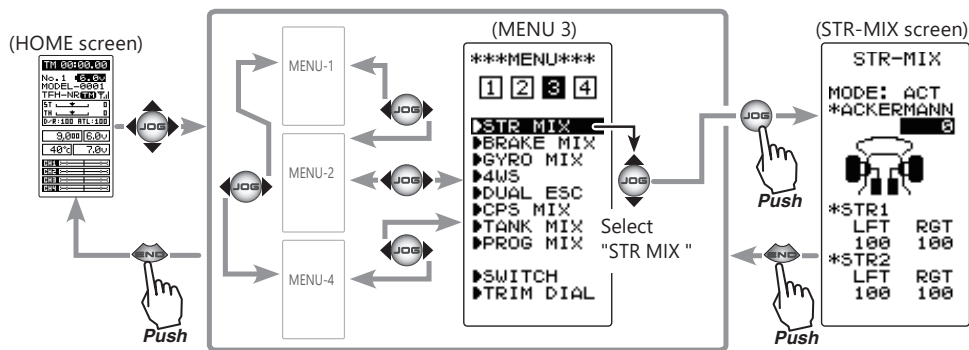

Setup items	
MODE:	Function ON/OFF
STR1 LFT:	Steering 1 Left side
STR1 RGT:	Steering 1 Right side
STR2 LFT:	Steering 2 Left side
STR2 RGT:	Steering 2 Right side

## Steering mixing adjustment

- 1 (Steering mixing function ON/OFF)  
Select the setting item "MODE" by moving the (JOG) button up or down. Set the function by pressing the (+) or (-) button.

"INH": Function OFF.  
"ACT": Function ON.

- When "(ESC>INH)" is displayed, the STR MIX cannot be used if the DUAL ESC function is not set to "INH".
- When "(CPS>INH)" is displayed, the STR MIX cannot be used if the CPS function is not set to "INH".
- When "(BRK4>INH)" is displayed, the STR MIX cannot be used if the BRAKE MIX (CH4) function is not set to "INH".

### Function ON/OFF (MODE)

INH, ACT

### Select button

- Select with the (+) or (-) buttons.

- 2 (Steering 1 rate)  
Select the setting item STR 1 "LFT" or "RGT" by moving the (JOG) button up or down. Adjust the left and right steering amounts using the (+) or (-) button.

### Steering 1 rate

(STR 1 LFT,RGT)

0 ~ 120

Initial value:100

### Adjustment buttons

- Use the (+) and (-) buttons to make adjustments.
- Return to the initial value by pressing the (+) and (-) buttons simultaneously (approx. 1 sec).

- 3 (Steering 2 rate)  
Select the setting item STR 2 "LFT" or "RGT" by moving the (JOG) button up or down. Adjust the left and right steering amounts using the (+) or (-) button.

### Steering 2 rate

(STR 2 LFT,RGT)

0 ~ 120

Initial value:100

### Adjustment buttons

- Use the (+) and (-) buttons to make adjustments.
- Return to the initial value by pressing the (+) and (-) buttons simultaneously (approx. 1 sec).

- 4 (Ackerman adjustment)  
Select the setting item "ACKERMANN" rate by moving the (JOG) button up or down.  
Adjust the left and right differential amount and adjust the Ackerman by (+) and (-) button.

### Ackerman rate

-100 ~ 0 ~ +100

Initial value:0

### Adjustment buttons

- Use the (+) and (-) buttons to make adjustments.
- Return to the initial value by pressing the (+) and (-) buttons simultaneously (approx. 1 sec).

- 5 When finished with the setting, return to the MENU screen by pressing the (END) button.

## Dial / Trim Setting

Ackerman rate can be controlled with digital dial or digital trim, using the function select trim dial function ([See page 104](#)).



This function is used when the front and rear brakes must be adjusted independently such as on a 1/5 scale GP car. This mixing uses the 2nd CH for the rear brakes and the 3rd or 4th CH for the front brakes, or controls the front brakes with the 3rd CH and 4th CH servos, or controls the 2nd CH by independent throttle and controls the rear and front brakes with the 3rd CH and 4th CH.

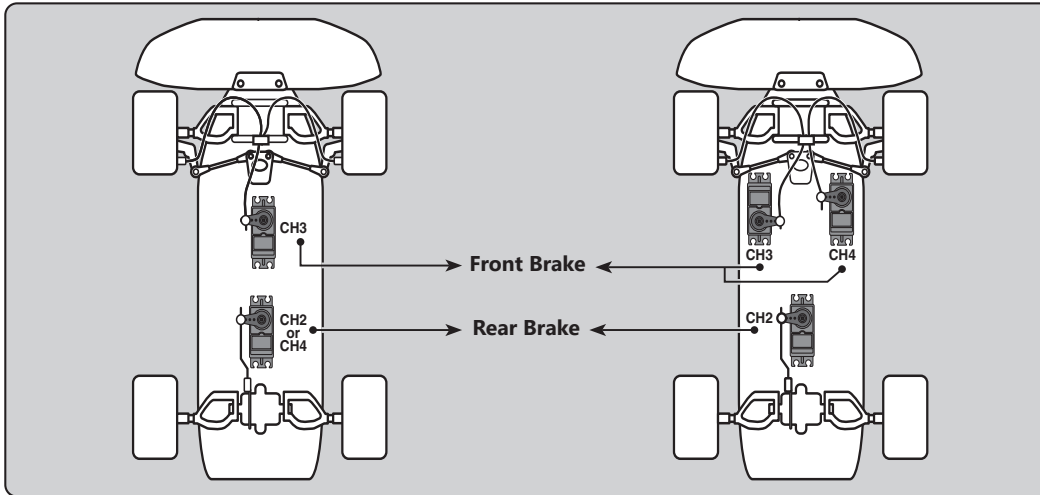

### Operation

- When braking, mixing is applied to 2nd CH→3rd CH, 4th CH.
- 3rd CH and 4th CH brake amount, 2nd CH, 3rd CH, and 4th CH brake delay, and 3rd CH and 4th CH brake ABS can be set.

### CH3/4 brake ABS function

The ABS function can be used independently at the CH3 and CH4 sides even when the CH2 side ABS function is OFF. The amount of pumping speed (CYCL), operation point (TG.P), and duty ratio (DUTY) can be set in common with the CH2 side ABS function. (CH3 and CH4 brake return (AB.P) is fixed at 50.)

Display "BRAKE MIX" screen using the following method:

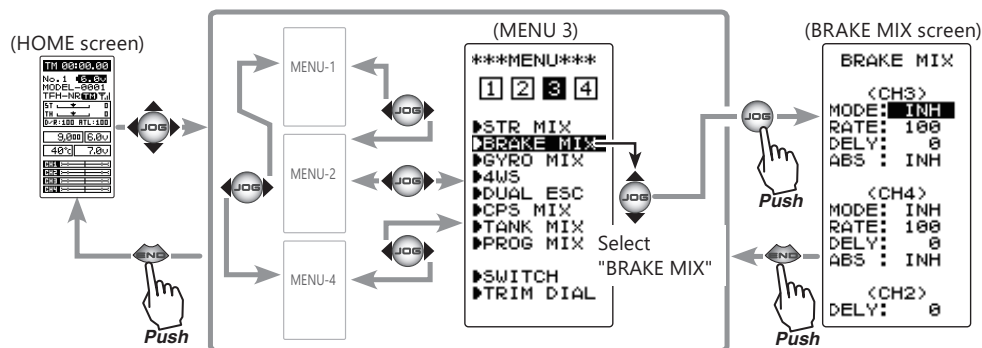

Setup item		
<CH3>	<CH4>	<CH2>
MODE: Brake function ON/OFF	MODE: Brake function ON/OFF	DELY: Delay amount
RATE: Brake rate	RATE: Brake rate	
DELY: Delay amount	DELY: Delay amount	
ABS: ABS. function ON/OFF	ABS: ABS. function ON/OFF	

## Brake mixing adjustment

- 1** (Brake mixing function ON/OFF)  
Select the setting item "MODE" of <CH3> for CH3 brake and "MODE" of <CH4> for CH 4 brake by moving the (JOG) button up or down, and use the (+) or (-) buttons to set the function to the "ACT" state.

"INH": Function OFF.  
"ACT": Function ON.

- When "(4WS>OFF)" is displayed below <CH3>ABS, the CH3 brake cannot be used if the 4WS function is not set to "OFF".
- When "(ESC>INH)" is displayed under <CH4>ABS, the CH4 brake cannot be used if the DUAL ESC function is not set to "INH".
- When "(SMX>INH)" is displayed under <CH4>ABS, the CH4 brake cannot be used if the STR MIX function is not set to "INH".

- 2** (Brake rate)  
Moving the (JOG) button up or down, select "RATE" of <CH3> for CH3 brake and "RATE" of <CH4> for CH 4 brake, and use the (+) and (-) buttons to adjust the Brake rate amount.

- 3** (Delay amount setup)  
Moving the (JOG) button up or down, select "DELY" of <CH3> for CH3 brake, "DELY" of <CH4> for CH 4 brake and "DELY" of <CH2> for CH 2 brake. Use the (+) and (-) buttons to adjust the delay amount.

"0": No delay.  
"100": Maximum delay amount.

- 4** (3rd & 4th channels brake-A.B.S ON/OFF)  
Moving the (JOG) button up or down, select "ABS" of <CH3> for CH3 brake and "ABS" of <CH4> for CH 4 brake. Use the (+) or (-) key and set the function to the "ACT" state.

- 5** When finished with the setting, return to the MENU screen by pressing the (END) button.

### Setting Special Mixes

In order to use 3CH of the brake mixing function, it is necessary to set [4WS \(page 114\)](#) and [Gyro MIX \(page 112\)](#) to the "INH" setting. In order to use 4CH, it is necessary to set [STR MIX \(page 108\)](#), [Dual ESC \(page 116\)](#) and [CPS MIX \(page 118\)](#) to the "INH" setting.

### Dial / Trim Setting

The function select dial function can control the 3rd/4th channels brake rate (RATE) can be controlled with digital dial or digital trim, using the function select trim dial function ([See page 104](#)).

#### Function ON/OFF (MODE)

INH, ACT

#### Select button

- Select with the (+) or (-) buttons.

#### Brake rate (RATE)

0 ~ 100

Initial value:100

#### Adjustment buttons

- Use the (+) and (-) buttons to make adjustments.
- Return to the initial value by pressing the (+) and (-) buttons simultaneously (approx. 1 sec).

#### Delay amount (DELY)

(CH3) 0 ~ 100

(CH4) 0 ~ 100

(CH2) 0 ~ 100

Initial value:0

#### Adjustment buttons

- Use the (+) and (-) buttons to make adjustments.
- Return to the initial value by pressing the (+) and (-) buttons simultaneously (approx. 1 sec).

#### Function ON/OFF (ABS)

INH, ACT

#### Select button

- Select with the (+) or (-) buttons.



This function is a remote gain function which adjusts the sensitivity of the Futaba car rate gyro at the T4PM PULS side, and is mixing that uses the 3rd CH to adjust the gyro sensitivity.

When using the T4PM PULS by switching the AVCS and normal modes, use SW1 or SW2 with the function select switch function (page 106).

For a description of the car rate gyro mounting method and handling, refer to the rate gyro instruction manual.

### Setting Special Mixes

When the 3rd CH was set to ACT at [Brake Mixing \(page 110\)](#) or when [4WS Mixing \(page 114\)](#) is used, Gyro mixing cannot be used.

### SR mode

When using SR mode compatible gyro in SR mode channel, set both steering input and gyro sensitivity input channel to SR mode. If either one is in normal mode, gyro will not operate properly.

### AVCS / NORMAL Modes

The gyro has 2 operating modes: NORMAL mode and AVCS mode. In the AVCS mode, the angle is controlled simultaneously with NORMAL mode rate control (swing speed). The AVCS mode increases straight running stability more than that of the NORMAL mode. Because the feel of operation is different, choose your favorite mode.

### Dial / Trim Setting

The gain amount can be adjusted by using the function trim dial function ([page 104](#)).

Display "GYRO MIX" screen using the following method:

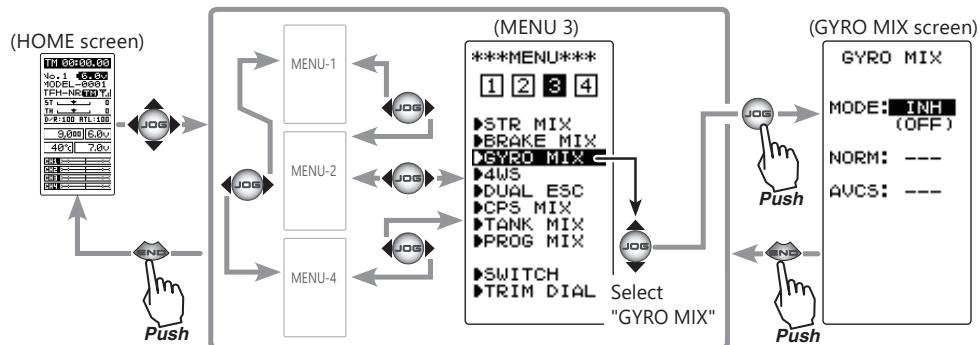



## Gyro mixing adjustment

(Preparation)

- Refer to the gyro instruction manual and connect the gyro to the receiver. When using remote gain, connect gyro sensitivity adjustment to the 3rd CH of the receiver.
- When using gyro mixing by switching between the NORM (normal) and AVCS modes, use the function select switch function ([page 106](#)) to set the switch to be used.

### 1 (Gyro mixing setting)

Select the setting item "MODE" by moving the (JOG) button up or down. Set the function by pressing the (+) or (-) button.

"INH": Function OFF.

"NORM": NORMAL mode gain.

"AVCS": AVCS mode gain.

"SEL": Switching Normal mode and AVCS mode.

(Displayed <NO SW> when the Gyro Mode SW is not used.)

- When "(4WS>OFF)" is displayed, the GYRO MIX cannot be used if the 4WS function is not set to "OFF".
- When "(BRAKE CH3 ACT→INH)" is displayed, the GYRO MIX cannot be used if the BRAKE MIX (CH3) function is not set to "INH".

#### Setup items

MODE: Gyro mode

NORM: Normal mode gain

AVCS: AVCS mode gain

#### Function SW

GYRO

#### Function selection (MODE)

INH, NORM, AVCS, SEL

#### Select button

- Select with the (+) or (-) buttons.

```
GYRO MIX
MODE: NORM
( ON)
NORM: 30
AVCS: ---
```

"NORM" mode

```
GYRO MIX
MODE: AVCS
( ON)
NORM: ---
AVCS: 30
```

"AVCS" mode

```
GYRO MIX
MODE: SEL
( ON)
NORM: 30
AVCS: 30
SWITCH
```

"SELE" mode

Shows the gyro mode select switch mode.

### 2 (NORMAL side gain adjustment)

Select the setting item "NORM" by moving the (JOG) button up or down. Adjust the NORMAL side gain with the (+) or (-) button.

(AVCS side gain adjustment)

Select the setting item "AVCS" by moving the (JOG) button up or down. Adjust the AVCS side gain with the (+) or (-) button.

```
GYRO MIX
<NO SW>
MODE: SEL
(OFF)
NORM: 30
AVCS: 30
SWITCH
```

< NO SW >

Displayed when the Gyro Mode SW is not used.

The function select switch screen (page 106) can be displayed from this screen.

#### NORMAL / AVCS gain

(NORM / AVCS)

0 ~ 120

Initial value:30

#### Adjustment buttons

- Use the (+) and (-) buttons to make adjustments.
- Return to the initial value by pressing the (+) and (-) buttons simultaneously (approx. 1 sec).

### 3 When finished with the setting, return to the MENU screen by pressing the (END) button.



# 4WS Mixing "4WS"

(Steering, 3rd channel system)

This function can be used with crawlers and other 4WS type vehicles. It is mixing which uses the 1st CH to control the front side steering and the 3rd CH to control the rear side steering.

OFF (front side only), reverse phase, same phase, rear side only and other 4WS type switching is used by selecting SW2 with the function select switch function [\(page 106\)](#). If not selected, <NO SW> is displayed. Therefore, select SW2.

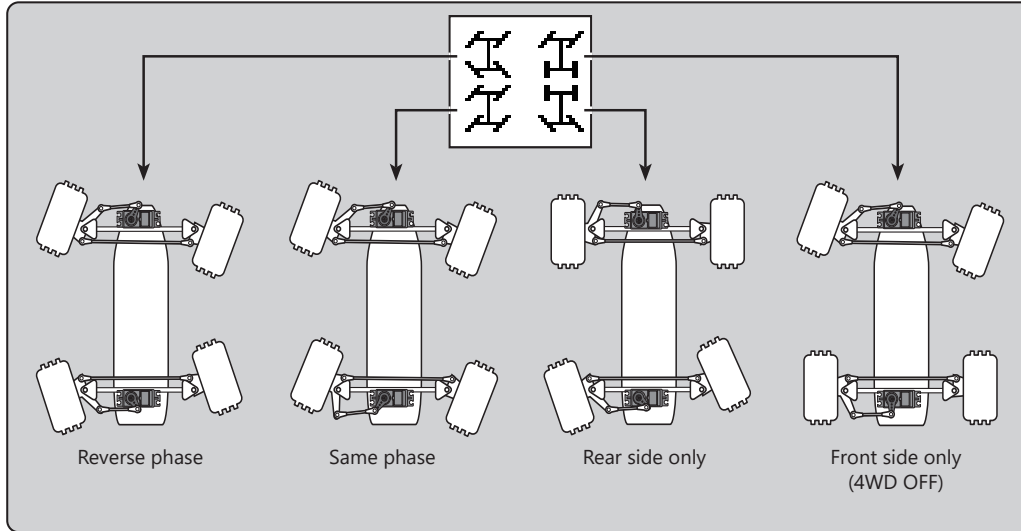

## Setting Special Mixes

When the 3rd CH was set to ACT at [Brake Mixing \(page 110\)](#) or when [Gyro Mixing \(page 112\)](#) is used, 4WS Mixing cannot be used.

Display "4WS" screen using the following method:

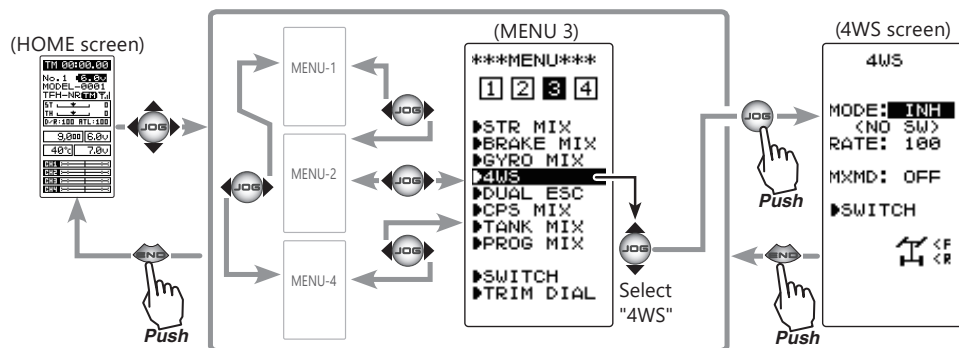

## 4WS mixing adjustment

(Preparation)

Since this function is used by switching the type of 4WS with a switch (SW2), the switch used by the function select switch function [\(page 106\)](#) is set.

### Setup items

- MODE: 4WS Type
- RATE: 3ch rate (Rear side)
- MXMD: Mix mode

### Function SW

4WS

# 1 (4WS type selection)

Select the setting item "MODE" by moving the (JOG) button up or down. Use the (+) or (-) and set the function to the "ON" or "OFF" state.

- "INH": Function OFF (front only).
- "2TYP": Front side only, reverse phase switching.
- "3TYP": Front side only, reverse phase and same phase switching.
- "4TYP": Front side only, reverse phase, same phase, and rear side only switching.

- When "(GYRO MIX ACT→INH)" is displayed, the 4WS cannot be used if the GYRO MIX function is not set to "INH".
- When "(BRAKE CH3 ACT→INH)" is displayed, the 4WS cannot be used if the BRAKE MIX (CH3) function is not set to "INH".

Switched in the order shown in the figure below by set SW (SW2).

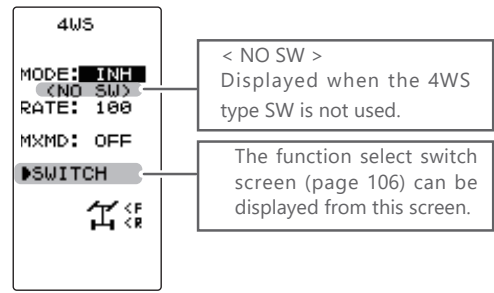

**Function ON/OFF (MODE)**  
OFF, 2TYP, 3TYP, 4TYP

**Select button**  
- Select with the (+) or (-) buttons.

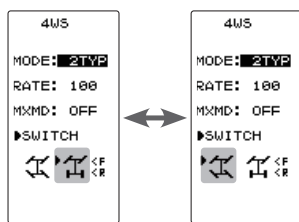

"2TYP": Front side only and reverse phase switching

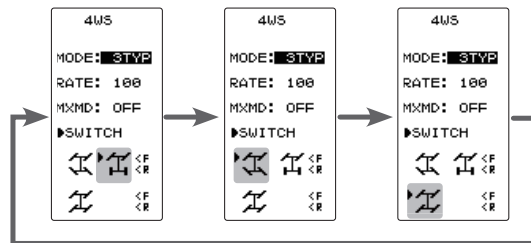

"3TYP": Front side only, reverse phase, and same phase switching

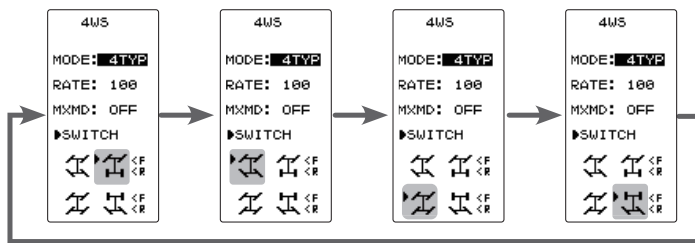

"4TYP": Front side only, reverse phase, same phase, and rear side only switching

# 2 (Rear side travel adjustment)

Select setting item "RATE" by moving the (JOG) button up or down. Adjust the rear side travel with the (+) or (-) button.

**Rear rate (RATE)**  
0 ~ 100  
Initial value: 100

**Adjustment buttons**  
- Use the (+) and (-) buttons to make adjustments.  
- Return to the initial value by pressing the (+) and (-) buttons simultaneously (approx. 1 sec).

# 3 (Mix mode setting)

Select setting item "MXMD" by moving the (JOG) button up or down. Set the mix mode with the (+) or (-) button.

- "OFF": The EXP function of the 1st CH and other settings are not mixed.
- "ON": The EXP function of the 1st CH and other settings are mixed.

**Mixing mode (MXMD)**  
OFF, ON  
Initial value: OFF

**Select button**  
- Select with the (+) or (-) buttons.

# 4 When finished with the setting, return to the MENU screen by pressing the (END) button.

This function is mixing used with crawlers and other 4WD type vehicles and uses the 2nd CH to control the front motor controller and the 4th CH to control the rear motor controller.

Front drive only, rear drive only, or both front and rear drive can be selected using any programmed DT (digital trim) button.

## Setting Special Mixes

When the 4th CH is set to ACT by [Brake Mixing \(page 110\)](#), or when [Steering mixing \(page 108\)](#) and [CPS Mixing \(page 118\)](#) are used, this dual ESC Mixing function cannot be used.

Display "DUAL ESC" screen using the following method:

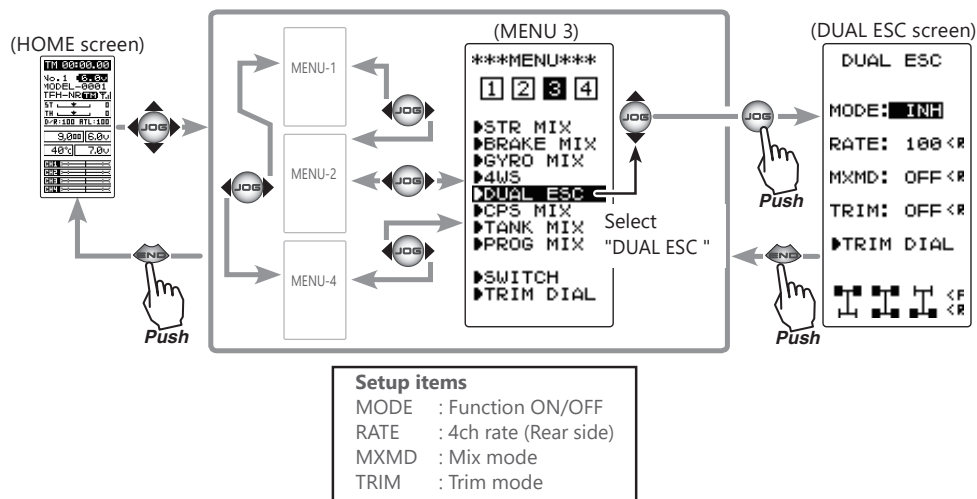

## Dual ESC mixing adjustment

(Preparation)

- This function is used to switch between front drive/4WD/rear drive using one of the trims (dial). Set the desired trims (dial) for this function using the TRIM DIAL screen (page 104).

- DT1 through DT6 or DL1.

### 1 (Dual ESC setting)

Select the setting item "MODE" by moving the (JOG) button up or down. Set the function by pressing the (+) or (-) button.

"INH": Function OFF.

"ACT": Function ON.

- When "(STR MIX ACT→INH)" is displayed, the DUAL ESC cannot be used if the STR MIX function is not set to "INH".
- When "(CPS MIX ACT→INH)" is displayed, the DUAL ESC cannot be used if the CPS function is not set to "INH".
- When "(BRK4 MIX ACT→INH)" is displayed, the DUAL ESC cannot be used if the BRAKE MIX (CH3) function is not set to "INH".

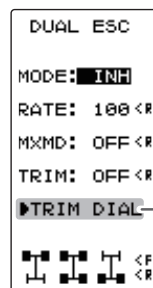

Function TRIM DIAL  
ESC-MD

The function select trim dial screen (page 104) can be displayed from this screen.

Function ON/OFF (MODE)  
INH, ACT

Select button

- Select with the (+) or (-) buttons.



The programmed DT button is used to select the drive type as shown in the figure below.

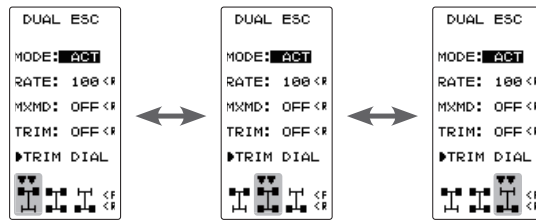

## 2 (Rear side travel adjustment)

Select the setting item "RATE" by moving the (JOG) button up or down. Use when applying a rotation difference to the front and rear wheels by adjusting the rear (CH4) motor controller travel with the (+) or (-) button.

### Rear rate (RATE)

0 ~ 120  
Initial value:100

### Adjustment buttons

- Use the (+) and (-) buttons to make adjustments.
- Return to the initial value by pressing the (+) and (-) buttons simultaneously (approx. 1 sec).

## 3 (Mix mode setting)

Select the setting item "MXMD" by moving the (JOG) button up or down. Set the mix mode with the (+) or (-) button.

### Mixing mode (MXMD)

OFF, ON  
Initial value: OFF

### Select button

- Select with the (+) or (-) buttons.

"OFF": CH2 EXP function and other settings are not mixed.  
"ON": CH2 EXP function and other settings are mixed.

## 4 (Trim mode setting)

Select the setting item "TRIM" by moving the (JOG) button up or down. Set the trim mode with the (+) or (-) button.

### Trim mode (TRIM)

OFF, ON  
Initial value: OFF

### Select button

- Select with the (+) or (-) buttons.

"OFF": Front side (CH2) trim data is not included.  
"ON": Front side (CH2) trim data is included.

## 5 When finished with the setting, return to the MENU screen by pressing the (END) button.

### Dial / Trim Setting

The function select dial function can control the 4th channel's ESC (Rear side) rate (RATE) with digital dial or digital trim, using the function select trim dial function ([See page 104](#)).

### Note:

As this function drives 2 separate motor controllers simultaneously, a mutual load is applied. Use this function carefully so that the motor controllers are not damaged. Futaba will not be responsible for motor controller, motor, and other vehicle trouble due to use of this function.

## CPS Mixing "CPS MIX"

This function controls the Futaba CPS-1 channel power switch.

Normally, when using the CPS-1 unit to operate vehicle lighting systems, the CPS-1 unit with LED connected is connected to a vacant switch channel and the LEDs are turned on and off by switch while the vehicle is running. However, when the CPS-1 mixing (CPS MIX) function is used, the LED can be turned on and off and flashed in step with steering and throttle operation, as well as being turned on and off by switch. The flashing speed (cycle) can also be set.

For instance, the LED can be flashed as a brake light by throttle brake side operation.

### Setting Special Mixes

When the 4th CH is set to ACT by [Brake Mixing \(page 110\)](#), or when [Steering Mixing \(page 108\)](#) and [Dual ESC Mixing \(page 116\)](#) are used, this CPS Mixing function cannot be used.

Display "CPS MIX" screen using the following method:

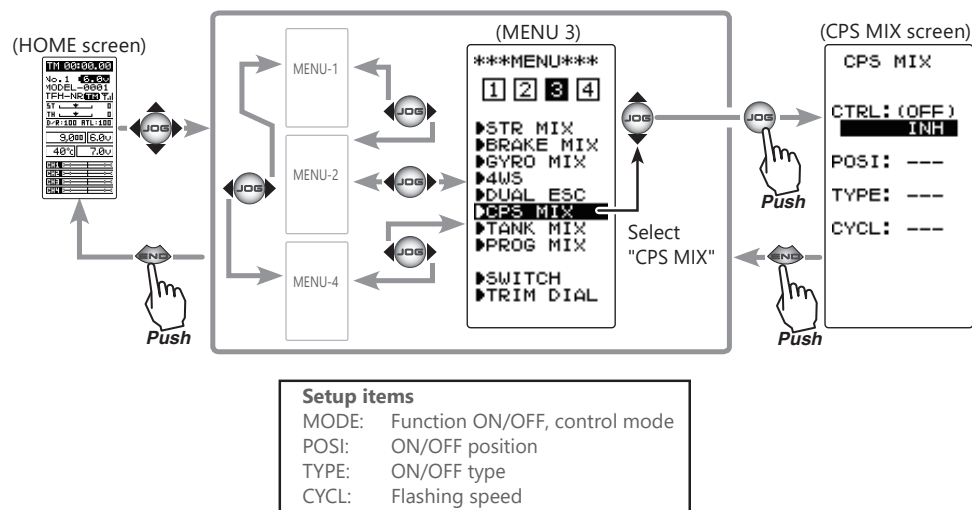

### CPS mixing adjustment

(Preparation)

- Connect the CPS-1 to the 4th CH of the receiver.
- When the LEDs are turned on and off by switch, use the function select switch function ([page 106](#)) to set the switch to be used.

Function SW  
CH4

## 1 (Control system setup)

Select the setting item "CTRL" by moving the (JOG) button up or down. Use the (+) or (-) button and select the function.

"INH": Function OFF.  
"CH4 FUNC": ON/OFF by switch set at the 4th CH.  
"STR NT": ON at steering neutral.  
"STR END": ON at both sides of steering.  
"THR NT": ON at throttle neutral.  
"THR FWD": ON at throttle forward side.  
"THR BRK": ON at throttle back (brake) side.  
"TH NT+BK": ON at throttle neutral and back (brake) sides.

- When "(ESC MIXACT→INH)" is displayed, the CPC MIX cannot be used if the DUAL ESC function is not set to "INH".
- When "(STR MIX ACT→INH)" is displayed, the CPS MIX cannot be used if the STR MIX function is not set to "INH".
- When "(BRK4> ACT→INH)" is displayed, the CPS MIX cannot be used if the BRAKE MIX (CH4) function is not set to "INH".

## 2 (ON/OFF switching position selection)

Select the setting item "POSI" by moving the (JOG) button up or down. Use the (+) or (-) button and select the ON/OFF position. Since the ON/OFF state is displayed at the right side of the setting item "CTRL", setting can be confirmed while operating the function to be controlled (for example, throttle).

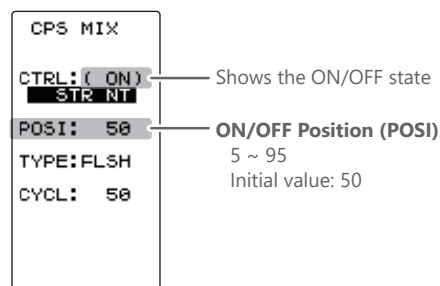

## 3 (ON/OFF type setup)

Select the setting item "TYPE" by moving the (JOG) button up or down. Use the (+) or (-) button and select the type of LED lighting. Normal ON/Off type or flashing can be selected.

"NORMAL": Normal ON/OFF type.  
"FLASH": Flashing display.

## 4 (Flashing cycle setting)

When flashing type "FLASH" is selected at the setting item "TYPE", the flashing speed (cycle) can be set.

Select the setting item "CYCL" by moving the (JOG) button up or down. Use the (+) or (-) button and select the flashing speed (cycle).

### Function selection (MODE)

INH, CH4 FUNC, STR NT, STR END, THR NT, THR FWD, THR BRK, TH NT+BK

### Select button

- Select with the (+) or (-) buttons.

### Function selection (TYPE)

NORMAL, FLASH

### Select button

- Select with the (+) or (-) buttons.

### Flashing cycle (CYCL)

1 ~ 100  
Initial value: 50

### Adjust button

- Use the (+) and (-) buttons to make adjustments.
- Return to the initial value by pressing the (+) and (-) buttons simultaneously (approx. 1 sec).

## 5 When finished with the setting, return to the MENU screen by pressing the (END) button.



This function is intended for vehicles such as tanks and can be used for the pivotal turn, or the ultra-pivotal brake turn, by steering and throttle operation.

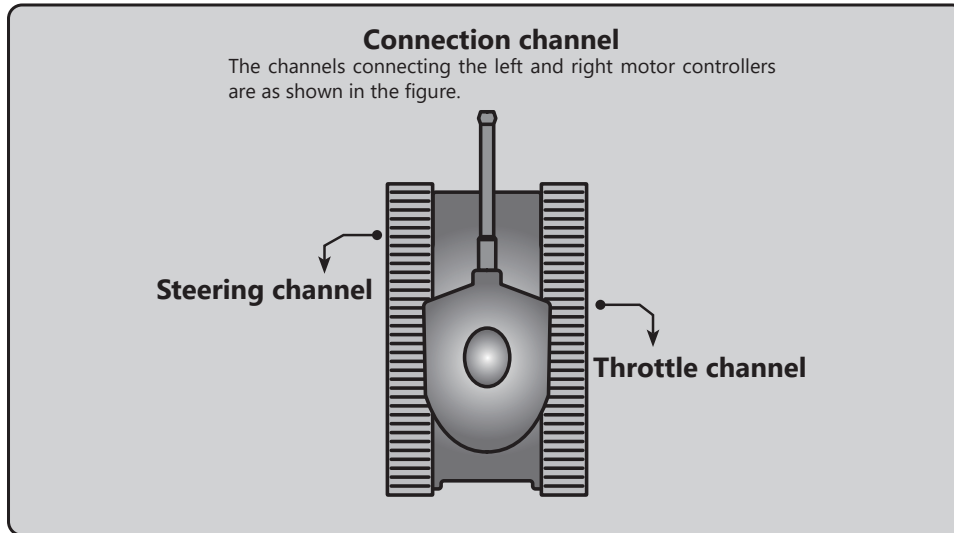

Display "TANK MIX" screen using the following method:

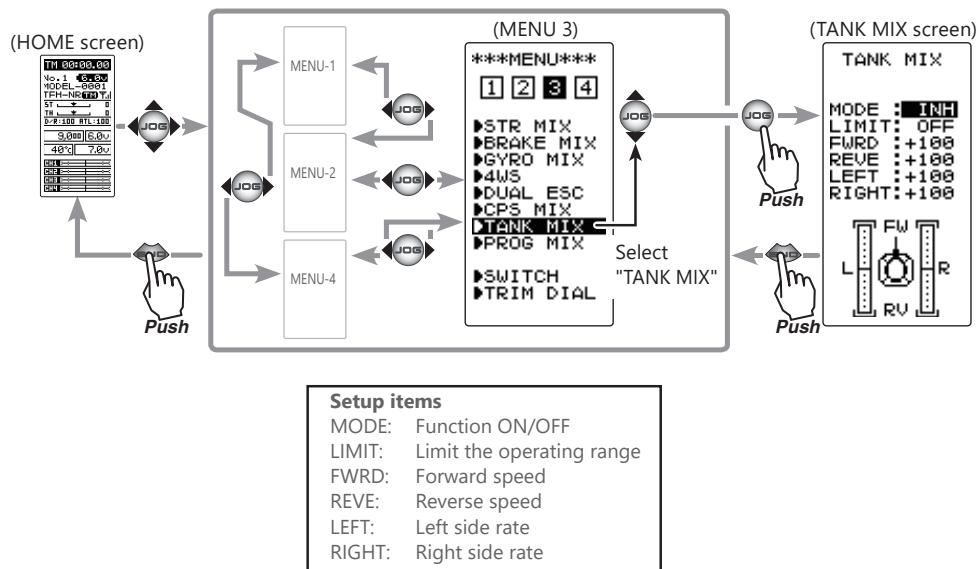



## Tank mixing adjustment

### 1 (Mixing function ON/OFF)

Select the setting item "MODE" by moving the (JOG) button up or down. Use the (+) or (-) button and set the function to the "ON" or "OFF" state.

"INH": Function OFF.

"ON": Function ON.

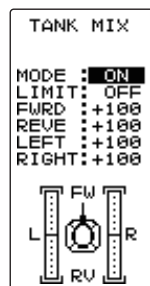

#### Select button

- Select with the (+) or (-) buttons.

#### Function ON/OFF (MODE)

INH,ON (OFF)

#### Select button

- Select with the (+) or (-) buttons.

### 2 (Limit ON / OFF)

This function limits the maximum operation amount of the steering and throttle channel so that it does not exceed the limit by the influence of the mixing amount. Select the setting item "LIMIT" by moving the (JOG) button up or down. Use the (+) or (-) button and set the function to the "ON" or "OFF" state.

"OFF": Limit function OFF

"ON": Limit function ON

#### Function ON/OFF (MODE)

INH,ON (OFF)

#### Select button

- Select with the (+) or (-) buttons.

### 3 (Forward / backward rate adjustment)

Select the setting item "FWRD" or "REVE" by moving the (JOG) button up or down. Use the (+) and (-) buttons to adjust the forward or reverse speed.

- The throttle channel and the steering channel operate in conjunction with each other, and by operating the trigger to the high side, the car body advances at the "FWRD" rate. When the trigger is operated to the brake side, it operates at the "Back" rate.

#### Forward (FWRD)

#### / Backward (REVE) rate

-100 ~ +100

Initial value: +100

#### Adjustment buttons

- Use the (+) and (-) buttons to make adjustments.  
- Return to the initial value by pressing the (+) and (-) buttons simultaneously (approx. 1 sec).

### 4 (Left / Right side travel adjust)

Select the setting item "LEFT" or "RIGHT" by moving the (JOG) button up or down. Use the (+) and (-) buttons to adjust the left or right side travel amount.

- When the throttle channel and the steering channel work in conjunction, when operating the steering wheel to the right, the car body turns to the right at the "RIGHT" rate the pivotal turn. If you operate to the left, the car will turn to the left at the "LEFT" rate the pivotal turn.

#### Left (LEFT)

#### / Right (RIGHT) rate

-100 ~ +100

Initial value: +100

#### Adjustment buttons

- Use the (+) and (-) buttons to make adjustments.  
- Return to the initial value by pressing the (+) and (-) buttons simultaneously (approx. 1 sec).

### 5 When finished with the setting, return to the MENU screen by pressing the (END) button.

#### When steering and trigger are operated at the same time.

If you manipulate the trigger to the high side and operate the steering wheel to the right, the tank will turn right at the rate of "FWRD", "RIGHT".

If you manipulate the trigger to the high side and operate the steering wheel to the left, the tank turns to the left at the rate of "FWRD", "LEFT".

Operating the steering wheel while operating the trigger to the brake side will operate the same as the forward side in the reverse direction.



This function allows you to apply mixing between steering, throttle, channel 3 and channel 4.

### Additional Functions

-When the steering or throttle channel is the master channel (channel that applies mixing), trim data can be added (Trim mode).

- The mixing mode selection (Master mixing mode).

Relating function

steering: EPA, STR EXP, D/R, SPEED, 4WS

throttle: EPA, THR EXP, ATL, ABS, SPEED, BRAKE MIX, NT-BRK, ESC MIX, TH ACCEL

CH3: EPA, BRAKE MIX, 4WS

CH4: EPA, BRAKE MIX, ESC MIX

### Movement of the slave channel side

The movement of the master channel side will be added to the movement of the slave channel side.

Display "PROG MIX" screen using the following method:

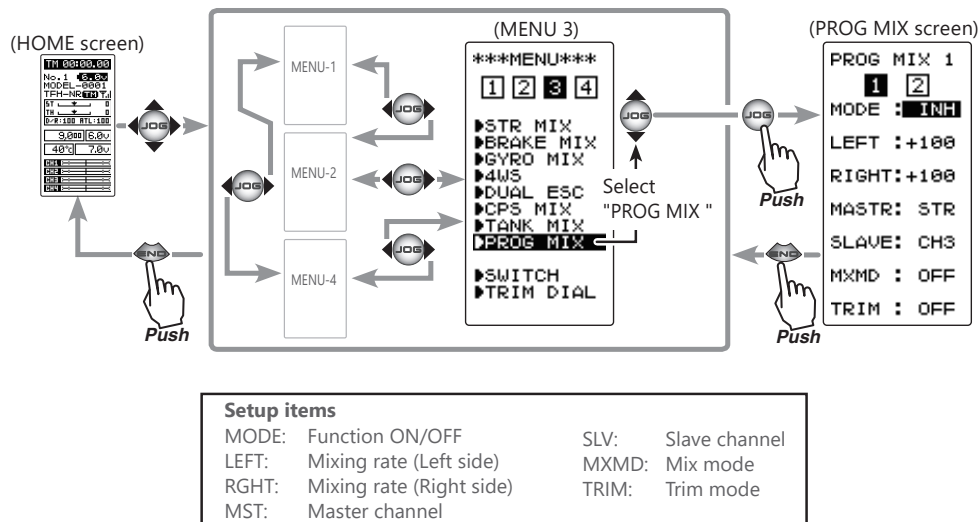

### Program mixing adjustment

(Preparation)

- When "PROG MIX" is turned ON and OFF by switch, set the switch by select switch function [\(page 106\)](#).

-Select the mixing "1" or "2" by moving the (JOG) button right or left.

#### 1 (Mixing function ON/OFF)

Select the setting item "MODE" by moving the (JOG) button up or down. Use the (+) or (-) and set the function to the "ON" or "OFF" state.

"INH": Function OFF.

"ON": Function ON. When the switch is OFF, "OFF" is displayed.

Function SW  
PROGMIX

Function ON/OFF (MODE)  
INH, ON (OFF)

Select button

- Select with the (+) or (-) buttons.

## 2 (Master channel)

Select setup item "MST" by moving the (JOG) button up or down, and select the master channel by pressing the (+) or (-) button.

These setup items are different depending on the master channel.  
Upper side : LEFT / FWRD / UP  
Lower side : RGHT / BRAK / DOWN

```
PROG MIX 1
 1 2
MODE : ON
LEFT : +100
RIGHT : +100
MASTR: STR
SLAVE: CH3
MXMD : OFF
TRIM : OFF
```

### Channel selection (MST)

STR, THR, CH3, CH4  
Initial value: STR

#### Select button

- Select with the (+) or (-) buttons.

## 3 (Slave channel)

Select setup item "SLV" by moving the (JOG) button up or down, and select the slave channel by pressing the (+) or (-) button.

### Channel selection (SLV)

STR, THR, CH3, CH4  
Initial value: CH3

#### Select button

- Select with the (+) or (-) buttons.

## 4 (Upper side mixing amount adjustment)

Select the setting item upper side (See an upper figure) by moving the (JOG) button up or down. Use the (+) or (-) button and adjust the upper side mixing amount.

### Mixing amount

-120~0~+120  
Initial value: +100

#### Adjustment buttons

- Use the (+) and (-) buttons to make adjustments.  
- Return to the initial value by pressing the (+) and (-) buttons simultaneously (approx. 1 sec).

## 5 (Lower side mixing amount adjustment)

Select the setting item lower side (See an upper figure) by moving the (JOG) button up or down. Use the (+) or (-) button and adjust the lower side mixing amount.

## 6 (Mixing mode setup)

Select setup item "MXMD" by moving the (JOG) button up or down, and use the (+) or (-) button to select the mixing mode.

"OFF": Mixing proportional to master channel operation.  
"MIX": Mixing by master channel another function considered.

### Mixing mode (MXD)

OFF, ON  
Initial value: OFF

#### Select button

- Select with the (+) or (-) buttons.

## 7 (Trim mode setup)

Select setup item "TRIM" by moving the (JOG) button up or down, and use the (+) or (-) button to select the mixing mode.

"OFF": Trim is removed.  
"ON": Trim is added.

### Trim mode (TRIM)

OFF, ON  
Initial value: OFF

#### Select button

- Select with the (+) or (-) buttons.

## 8 When finished with the setting, return to the MENU screen by pressing the (END) button.

### Switch / Dial / Trim Setting

When the program mixing function ON/OFF by switch, use the function select switch function ([see page 106](#)). Mixing rate (RATE) can be controlled with digital dial or digital trim, using the function select trim dial function ([see page 104](#)).



# Timer Function "TIMER"

Use the timer by selecting one of the three timers UP TIMER, DOWN TIMER, and LAP TIMER.

Display "TIMER" screen using the following method:

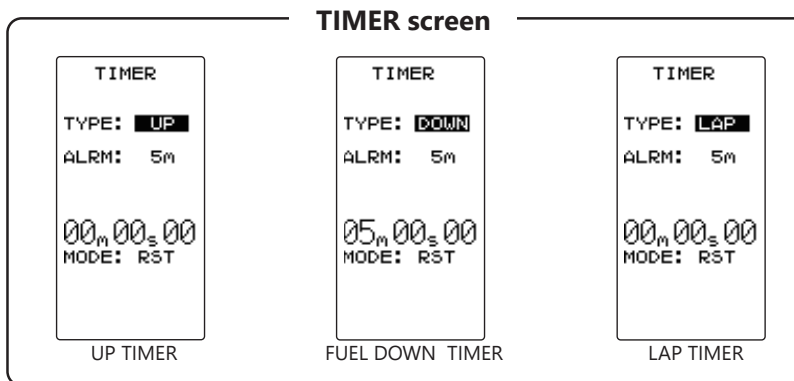
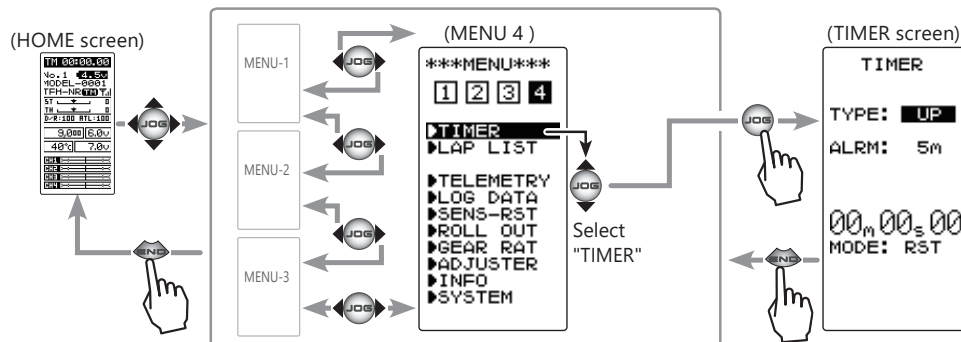

## UP TIMER function

### Up timer function

- This function can be used to count the time between start and stop, etc.
- The timer repeatedly starts and stops each time the switch is pressed and accumulates the time between each start and stop. When the count reaches 99 minutes 99 seconds, the count returns to 00 minutes 00 seconds and is repeated.
- The first start operation can be linked to the throttle trigger.
- The passage of time is announced by sounding of a buzzer (beep) each minute after starting.
  - Alarm: Beep sounds at the set time (minute).
  - Prealarm: Alarm advance announcement sound. Beeping begins 5 seconds before the alarm (beeps).
- After starting, the timer continues to count and can be stopped by switch even when the LCD switches to another screen.

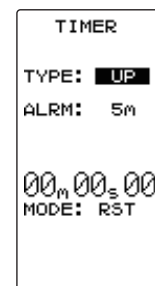

## FUEL DOWN TIMER function

### Fuel down timer function

- This function is primarily used to check the refueling time of a gasoline car. (The remaining time is displayed.)
- Each time the switch is pressed, the timer is restarted and the set time is re-set. The start time becomes the alarm set time. (When counted down to 00 minute 00 second, the down timer becomes an up timer.)
- The down timer can be initially started by throttle trigger.
- The passing of time is indicated by sounding of a buzzer (beep) each minute after starting.
  - Alarm: Beep sounds at the set time (minute).
  - Prealarm: Alarm advance announcement sound. Beeping begins 5 seconds before the alarm (beeps).
- After starting, the timer continues to count even if the LCD switches to another screen.

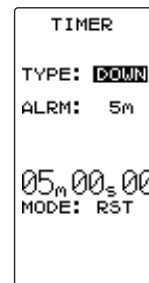

## LAP TIMER

### Lap timer function

- Each lap time can be memorized by switch operation. (100 laps)
- The race time can be set. Switch operation after the time set by alarm has elapsed automatically stops the timer. The passing of time is indicated by sounding of a buzzer (beep) each minute after starting.
  - Alarm: Beep sounds at the set time (minute).
  - Prealarm: Alarm advance announcement sound. Beeping begins 5 seconds before the alarm (beeps).
- The lap timer can be started by throttle trigger.

### (LAP TIMER operation)

- The lap timer is started by switch or throttle trigger.
  - Number of laps (LAP): After starting, the timer is counted up and the lap time blinks for 3 seconds each time the switch is pressed. To prevent erroneous counting, switch operation is not accepted during this period. When 1 lap exceeds 10 minutes, counting is repeated from 0.
  - Lap list: Up to 10 lap times are memorized beginning from lap list 1. After lap memory "100", operation returns to lap memory "1" and the lap memories are overwritten.
  - The lap time data memorized in the lap memories can be checked with the lap list screen ([page 130](#)). The entire lap list data is cleared the next time the lap timer is started.
  - TIME: For the first 3 seconds, the preceding lap time is displayed. After that the current lap time is displayed.

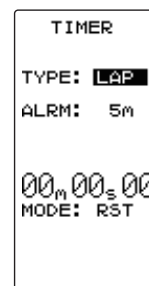

## Timer screen

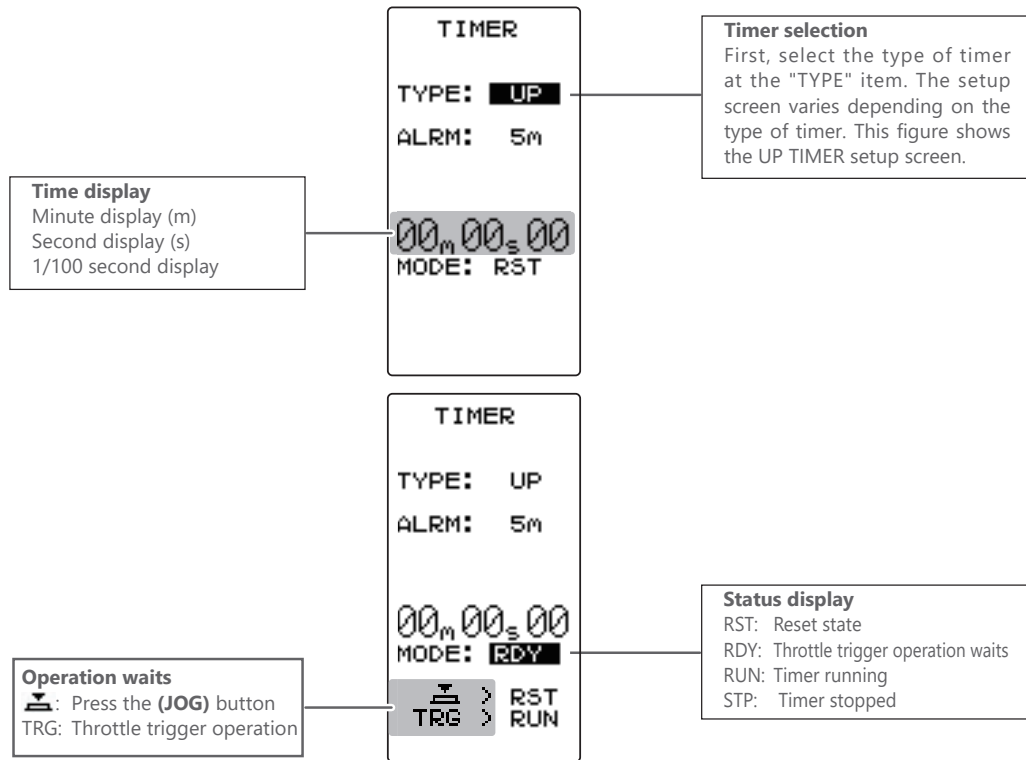

### Racing timer type selection

(Preparation)

Assign the "TIMER" switch using the function select switch ([see page 106](#)).

#### 1 (Racing timer type selection)

Select the setting item "TYPE" by moving the (JOG) button up or down. Use the (+) or (-) button and set the racing timer type.

Timer selection (TYPE).  
"UP": Up timer.  
"DOWN": Down timer.  
"LAP": Lap timer.

2 When finished with the setting, return to the MENU screen by pressing the (END) button.

#### Setup item selection

- Select by the (JOG) button.

#### Adjustment buttons

- Use the (+) and (-) buttons to make adjustments.

## Using the up timer

(Preparation)

Select the setting item "TYPE" by moving the (JOG) button up or down. Press the (+) or (-) button and select "UP".

### 1 (Alarm time setting)

Select the setting item "ALRM" by moving the (JOG) button up or down. Set the alarm time with the (+) or (-) button.

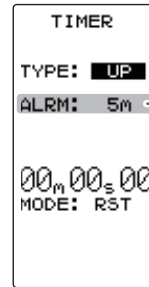

#### Adjustment buttons

- Use the (+) and (-) buttons to make adjustments.
- Press the (+) and (-) buttons simultaneously (approx. 1 sec) to return to the HOME screen.

#### Alarm time (ALRM)

OFF, 1 ~ 99 m  
Initial value: 5 m

### 2 (Timer start/stop operation)

Start the timer by pressing the switch ("TIMER") set by function select switch function ([see page 106](#)). Stop the timer with the same switch that starts it.

- Linking only start to the throttle trigger

Select the setting item "RST" by moving the (JOG) button up or down and press the (JOG) button for approximately 1 second. When the set beeps and the status display switches from "RST" to blinking "RDY", the system enters the trigger operation ready state. When the trigger is operated at the forward side, the timer starts. (Status display "RUN")

If the (END) button is pressed while the timer is operating, the LCD returns to MENU screen.

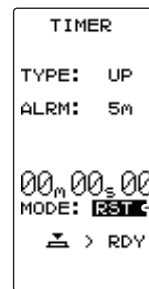

#### Switches

Time start / stop

#### Status display

RST: Reset state  
RDY: Throttle trigger operation waits  
RU: Timer running  
STP: Timer stopped

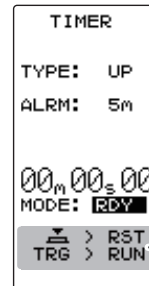

#### Operation waits

: Press the (JOG) button  
TRG: Throttle trigger operation

### 3 (Timer reset operation)

Select a status display ("RUN" or "STP") by moving the (JOG) button up or down and press the (JOG) buttons for approximately 1 second. A beep is generated and "RST" appears on the status display and the timer resets.

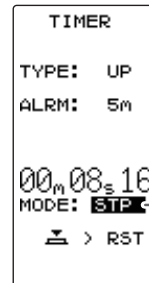

#### Status display

RST: Reset state  
RDY: Throttle trigger operation waits  
RUN: Timer running  
STP: Timer stopped



## Using the fuel down timer

(Preparation)

Select the setting item "TYPE" by moving the (JOG) button up or down. Press the (+) or (-) button and select "DOWN".

### 1 (Alarm time setting)

Select the setting item "ALRM" by moving the (JOG) button up or down. Set the alarm time with the (+) or (-) button.

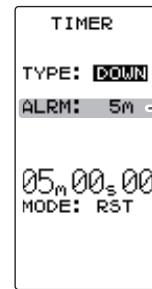

#### Adjustment buttons

- Use the (+) and (-) buttons to make adjustments.
- Press the (+) and (-) buttons simultaneously (approx. 1 sec) to return to the HOME screen.

#### Alarm time (ALRM)

OFF, 1 ~ 99 m  
Initial value: 5 m

### 2 (Alarm start/restart operation)

When the switch ("TIMER") set by function select switch function ([see page 106](#)) is pressed, the timer starts. When the same switch is pressed while the timer is operating, the timer is reset and simultaneously restarted. (Restart)

- Linking only start to the throttle trigger

Select the setting item "RST" by moving the (JOG) button up or down and press the (JOG) button for approximately 1 second. When the set beeps and the status display switches from "RST" to blinking "RDY", the system enters the trigger operation ready state.

When the trigger is operated at the forward side, the timer starts. (Status display "RUN")

If the (END) button is pressed while the timer is operating, the LCD returns to MENU screen.

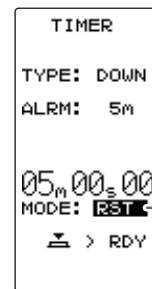

#### Switches

Timer start / restart

#### Status display

RST: Reset state  
RDY: Throttle trigger operation waits  
RUN: Timer running

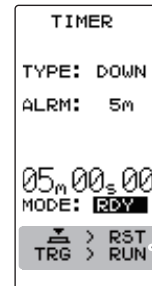

#### Operation waits

: Press the (JOG) button  
TRG: Throttle trigger operation

### 3 (Timer reset operation)

Select a status display ("RUN") by moving the (JOG) button up or down and press the (JOG) button for approximately 1 second. A beeping sound is generated and "RST" appears on the status display and the timer resets.

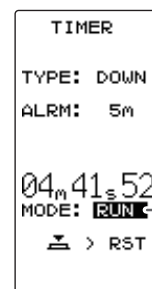

#### Status display

RST: Reset state  
RDY: Throttle trigger operation waits  
RUN: Timer running





## Using the Lap timer

(Preparation)

Select the setting item "TYPE" by moving the (JOG) button up or down. Press the (+) or (-) button and select "LAP".

### 1 (Alarm time setting)

Select the setting item "ALRM" by moving the (JOG) button up or down and set the alarm time with the (+) and (-) buttons.

#### Adjustment buttons

- Use the (+) and (-) buttons to make adjustments.
- Press the (+) and (-) buttons simultaneously (approx. 1 sec).

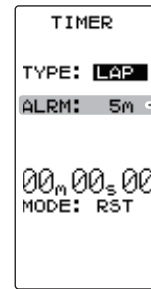

#### Alarm time (ALRM)

OFF, 1 ~ 99 m  
Initial value: 5 m

### 2 (Timer start/ lap count/ stop operation)

When the switch ("TIMER") set by function select switch function ([see page 106](#)) is pressed, the timer starts. During operation, the same switch becomes the lap switch and when the set time elapses, the timer is stopped by the same switch.

- Linking only start to the throttle trigger

Select the setting item "RST" by moving the (JOG) button up or down and press the (JOG) button for approximately 1 second. When the set beeps and the status display switches from "RST" to blinking "RDY", the system enters the trigger operation ready state. When the trigger is operated at the forward side, the timer starts. (Status display "RUN")

When the switch (TIMER) is pressed after the time set by alarm has elapsed, the timer stops and the lap time and total time are memorized. The status display becomes "GOAL".

If the (END) button is pressed while the timer is operating, the LCD returns to MENU screen.

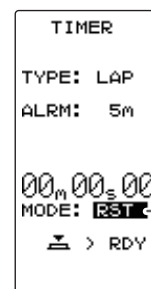

#### Switches

Timer start / Lap count

#### Status display

RST: Reset state  
RDY: Throttle trigger operation waits  
RUN: Timer running

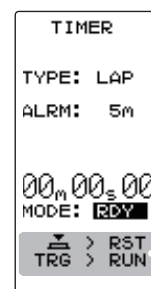

#### Operation waits

: Press the (JOG) button  
TRG: Throttle trigger operation

### 3 (Timer reset operation)

Select a status display ("GOAL") using the (JOG) button and press the (JOG) button for approximately 1 second. A beeping sound is generated and "RST" appears on the status display and the timer resets.

- When reset operation was performed before the "ALRM" set time had elapsed, the total time is not memorized.

- The lap memory data can be checked with the lap list ([page 130](#)) screen.

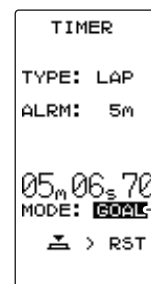

#### Status display

RST: Reset state  
RDY: Throttle trigger operation waits  
RUN: Timer running



## Lap List "LAP LIST"

The lap list is displayed when checking the lap memory data (lap times) memorized by lap timer (page 129) operation.

- After the lap timer starts, the lap times are memorized sequentially each time the switch is operated.

- If the timer is stopped after the set ALRM time has elapsed, the final lap time is memorized and the total time after the last lap is automatically written.

- When the timer was stopped before the set ALRM time has elapsed, the total time is not memorized.

Display "LAP LIST" screen using the following method:

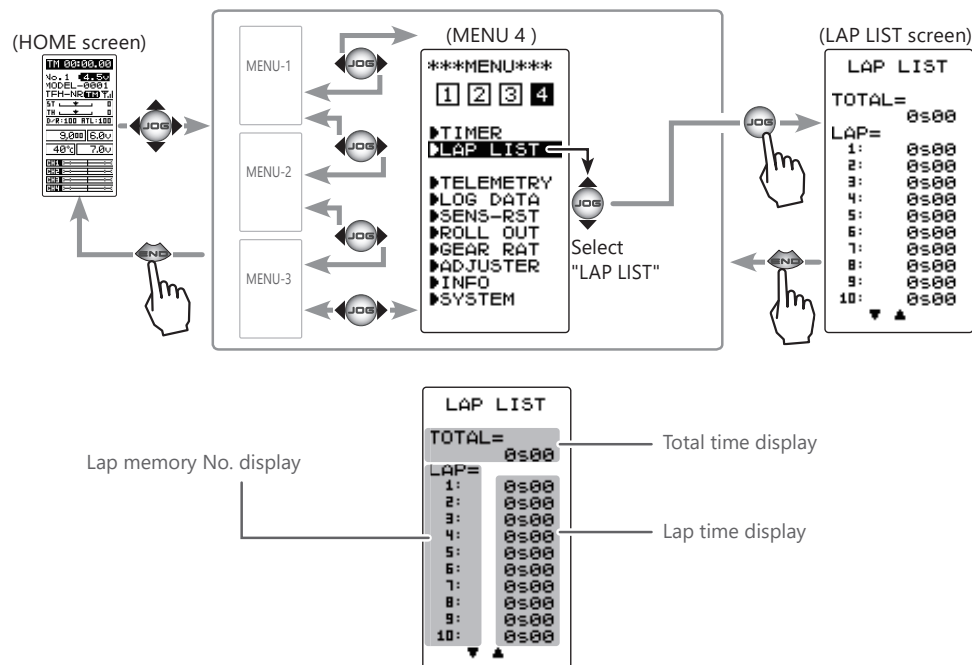

### Using the lap memory

#### 1 (Lap memory check)

When moving the (JOG) button up or down, the list is scrolled every 10 laps and each lap time can be checked.

#### 2 (Lap memory total data reset)

Press the (+) and (-) buttons simultaneously for approximately 1 second. A beeping sound is generated and all the data is reset.

#### Reset button

- Reset by pressing the (+) and (-) buttons simultaneously for about 1 second.

#### 3 To return to the MENU screen by pressing the (END) button.

## Telemetry "TELEMETRY"

With the telemetry system, the running status can be displayed at the transmitter and also recorded as a data log by mounting various sensor units to the chassis.

The T4PM PLUS displays four kinds of information on the HOME screen; receiver power source (battery) voltage, external power supply (drive battery) voltage, speed, and temperature.

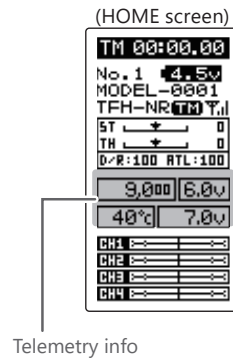

- \* The telemetry function is compatible with only the T-FHSS system.
- \* The telemetry function requires a corresponding receiver. (R304SB, 334SBS)
- \* Only T4PM PLUS with telemetry receiver's ID registered have a telemetry display.
- \* Multiple sensors of the same type cannot be used.

The sensor data can be checked at the transmitter by connecting the telemetry sensor sold separately to the S.BUS2 connector of the R304SB receiver.

The figure (page 132) is an example of connection of a telemetry sensor. The data of 3 types of sensors and the receiver power supply voltage can be transmitted by using the 3-way extension cord or double extension cord sold separately.

The receiver power supply can also be connected to the S.BUS2 connector or each of CH 1 to 4. A receiver power supply voltage sensor is unnecessary.

\*The S.BUS2 system exerts control by connecting multiple gyros, servos and other devices corresponding to one S.BUS2 connector. Each device is separately controlled by setting the channel No. or slot No. individually for each device.

A slot No. is also set for telemetry sensors. With the T4PM PLUS system, each slot No. of a telemetry sensor must be set to its initial value. Since the slot No. can be changed for other aircraft type transmitters (T7PX, etc.), sensors with changed slot No. will not operate if not returned to their initial slot No.

When using a sensor that is used with transmitters other than a T4PM PLUS, whether or not the slot No. is set to the initial value given in the sensor instruction manual must be checked at the changed transmitter (T7PX, etc.). With the T4PM PLUS, the set slot No. cannot be checked or changed. So, essentially, if a sensor has been used in a 7PX, and you want to use the same sensor with your 4PM PLUS, you must first change the slot number through the 4PX or it will not work in your 4PM PLUS.

## Connection diagram

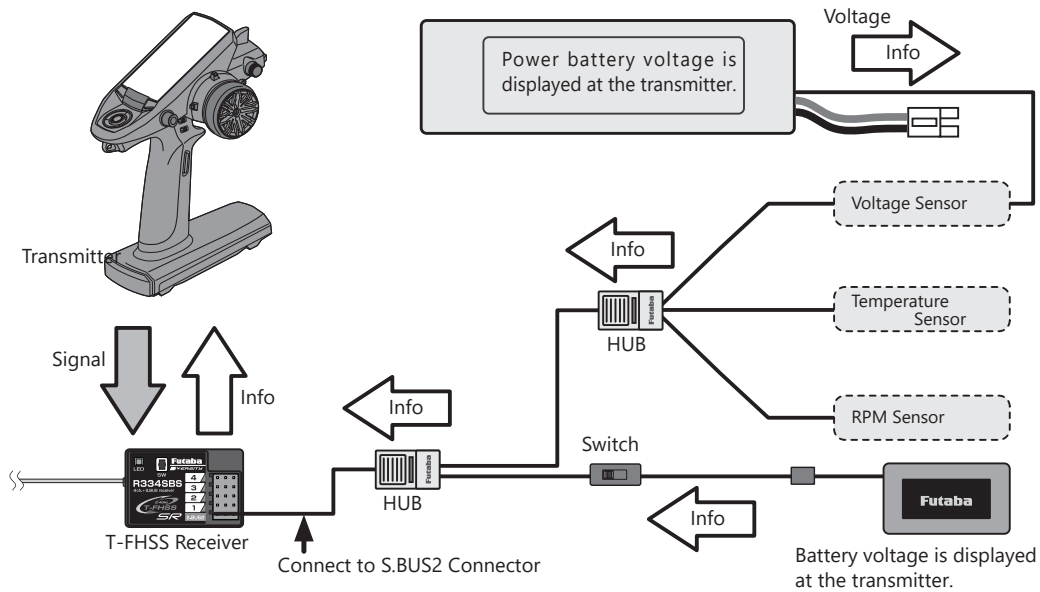

Temperature Sensor (SBS-01T)  
 Temperature Sensor (SBS-01TE)  
 RPM Sensor (SBS-01RM)  
 Brushless motor RPM Sensor (SBS-01RB)  
 Voltage Sensor (SBS-01V)  
 Current Sensor (SBS-01C)

## Telemetry Function ON/OFF

The telemetry data can be viewed at the HOME screen and telemetry ON/OFF screen. The telemetry function can also be turned on and off at the telemetry ON/OFF screen. The telemetry ON/OFF and communication status can be checked at the HOME screen.

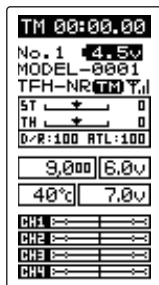

The reception strength

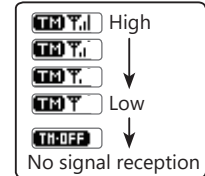

Y.i Receiver -> Transmitter:  
 The reception strength is shown.

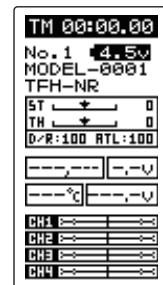
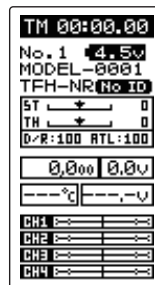

- Telemetry function: ON
- Receiver ID setting complete.
- Data receiving sensitivity display.
- **TM OFF** shows that data cannot be received because it is outside the data receiving range or because of the effects of an obstruction or the receiver power is OFF after receiver ID check.

- Telemetry function: ON
- Receiver ID before setting or ID mismatch.
- When the receiver ID is set, before ID check in the receiver power OFF stat.

Telemetry function: OFF

Display "TELEMETRY" screen using the following method:

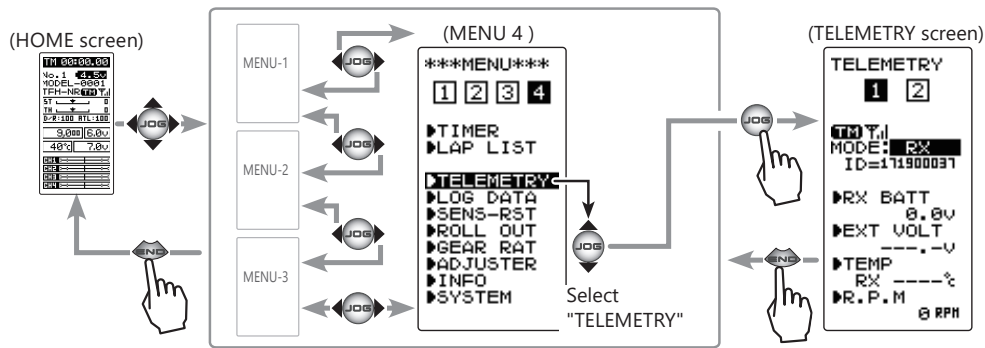

### Telemetry function ON/OFF

- 1 Select the setting item "MODE" by moving the (JOG) button. Set the function by pressing the (+) or (-) button.

"OFF": Function OFF.  
 "RX": Function ON. Each telemetry sensor  
 "MC970": Function ON. ESC MC970CR's information  
 \*MC970CR is available only in the Japanese market.  
 (As of August 2022)



Function ON/OFF (MODE)  
 Select button  
 - Select with the (+) or (-) buttons.

- 2 When finished with the setting, return to the MENU screen by pressing the (END) button.

(TELEMETRY screen: RX page 1)

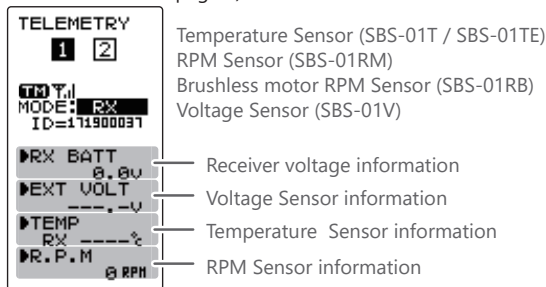

(TELEMETRY screen: RX page 2)

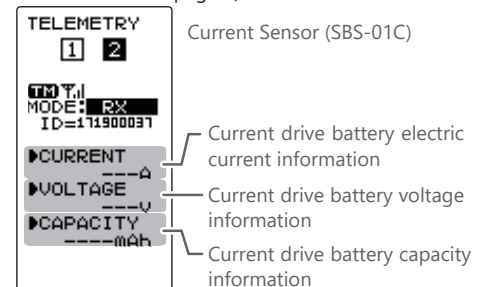

(TELEMETRY screen: MC970)

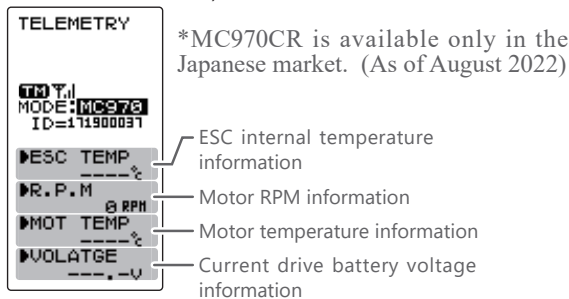

(TELEMETRY screen: OFF)

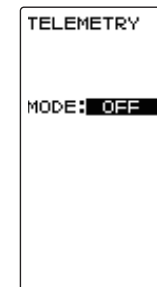

# Telemetry Sensor Setting

An audible alarm can be generated by the T4PM PLUS from the data from a telemetry sensor. This setting sets alarm ON/OFF and the alarm conditions.

## Setting the receiver power supply voltage

(Preparation)

MODE: RX (Page 1)

Select the setting item "RX BATT" by moving the (JOG) button up or down, and display the receiver power supply voltage screen by pressing the (JOG) button.

### 1 (Setting of each item)

Select the setting item "ALRM" by moving the (JOG) button up or down, and set alarm ON/OFF with the (+) button or (-) button.

"OFF": Alarm OFF.

"ON": Alarm ON by a voltage drop below the specified voltage.

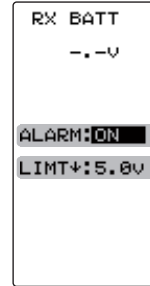

#### Alarm ON/OFF

ON, OFF

- Select with the (+) or (-) buttons.

#### Voltage alarm

- Adjust with the (+) and (-) buttons.

- Return to the initial value by pressing the (+) and (-) buttons simultaneously (approx. 1 sec).

### 2 (Setting the receiver power supply voltage alarm)

Select the setting item "LIMT" by moving the (JOG) button up or down, and set the voltage at which the alarm begins to sound with the (+) button or (-) button.

When finished with the setting, return to the TELEMETRY screen by pressing the (END) button.

## Setting external power supply voltage

(Preparation)

MODE: RX (Page 1)

Select the setting item "EXT VOLT" by moving the (JOG) button up or down, and display the external power supply voltage screen by pressing the (JOG) button.

### 1 (Setting of each item)

Select the setting item "ALRM" by moving the (JOG) button up or down., and set alarm ON/OFF with the (+) button or (-) button.

"OFF": Alarm OFF.

"ON": Alarm ON by a voltage drop below the specified voltage.

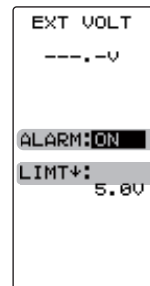

#### Alarm ON/OFF

ON, OFF

- Select with the (+) or (-) buttons.

#### Voltage alarm

- Adjust with the (+) and (-) buttons.

- Return to the initial value by pressing the (+) and (-) buttons simultaneously (approx. 1 sec).

### 2 (Setting the external power supply voltage alarm)

Select the setting item "LIMT" by moving the (JOG) button up or down, and set the voltage at which the alarm begins to sound with the (+) button or (-) button.

When finished with the setting, return to the TELEMETRY screen by pressing the (END) button.



## Setting the temperature

(Preparation)

MODE: RX (Page 1)

Select the setting item "TEMP" by moving the (JOG) button up or down, and display the temperature screen by pressing the (JOG) button.

### 1 (Select Celsius or Fahrenheit)

Select the setting item "UNIT" by moving the (JOG) button up or down, and select Celsius or Fahrenheit temperature display with the (+) button or (-) button.

"°C": Celsius.

"°F": Fahrenheit.

### 2 (Setting of each item)

Select the setting item "ALRM" by moving the (JOG) button up or down, and set alarm ON/OFF with the (+) button or (-) button.

"OFF": Alarm OFF.

"ON": Alarm ON at the specified temperature.

### 3 (Setting the temperature alarm)

Select the setting item "LIMIT" by moving the (JOG) button up or down, and set the temperature at which the alarm begins to sound with the (+) button or (-) button.

Select the setting item "TYPE" by moving the (JOG) button up or down, and set the type of sensor with the (+) button or (-) button.

"SBS-01T" Option sensor.

"Temp 125": Option sensor for Europe.

When finished with the setting, return to the TELEMETRY screen by pressing the (END) button.

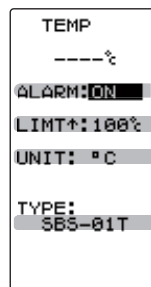

#### Alarm ON/OFF

ON, OFF

- Select with the (+) or (-) buttons.

#### Temperature alarm

-20~200°C/ -4~392°F

Initial value: 200°C/ 212°F

#### Adjust button

- Adjust with the (+) and (-) buttons.

- Return to the initial value by pressing the (+) and (-) buttons simultaneously (approx. 1 sec).

#### Unit type

°C, °F

- Select with the (+) or (-) buttons.

#### Sensor type

SBS-01T, Temp 125

#### Select button

- Select with the (+) or (-) buttons.

## Setting the gear ratio

(Preparation)

MODE: RX (Page 1)

Select "R.P.M" by moving the (JOG) button up or down, and display RPM screen by pressing the (JOG) button.

### 1 (Setting the RPM Gear Ratio)

Select the setting item "RATIO" by moving the (JOG) button up or down, and set the location the sensor is to actually measure and the gear ratio of the motor and engine with the (+) button or (-) button. There is no alarm function.

When finished with the setting, return to the TELEMETRY screen by pressing the (END) button.

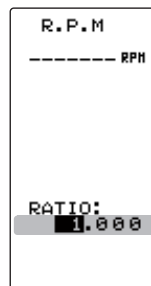

#### Gear ratio (moderating ratio)

- Adjust with the (+) and (-) buttons.

- Return to the initial value by pressing the (+) and (-) buttons simultaneously (approx. 1 sec).



## Setting the current sensor

(Preparation)

MODE: RX (Page 2)

### (Current drive battery electric current)

Select the setting item "CURRENT" by moving the (JOG) button up or down, and display the external power supply current screen by pressing the (JOG) button.

#### 1 (Setting of each item)

Select the setting item "ALRM" by moving the (JOG) button up or down., and set alarm ON/OFF with the (+) button or (-) button.

"OFF": Alarm OFF.

"ON": Alarm ON by the specified current.

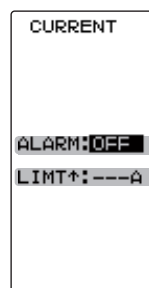

#### Alarm ON/OFF

ON, OFF

- Select with the (+) or (-) buttons.

#### Current alarm

- Adjust with the (+) and (-) buttons.

- Return to the initial value by pressing the (+) and (-) buttons simultaneously (approx. 1 sec).

#### 2 (Setting the external power supply voltage alarm)

Select the setting item "LIMT" by moving the (JOG) button up or down, and set the current at which the alarm begins to sound with the (+) button or (-) button.

When finished with the setting, return to the TELEMETRY screen by pressing the (END) button.

### (Current drive battery voltage)

Select the setting item "VOLTAGE" by moving the (JOG) button up or down, and display the external power supply voltage screen by pressing the (JOG) button.

#### 1 (Setting of each item)

Select the setting item "ALRM" by moving the (JOG) button up or down., and set alarm ON/OFF with the (+) button or (-) button.

"OFF": Alarm OFF.

"ON": Alarm ON by a voltage drop below the specified voltage.

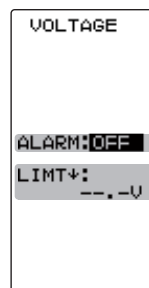

#### Alarm ON/OFF

ON, OFF

- Select with the (+) or (-) buttons.

#### Voltage alarm

- Adjust with the (+) and (-) buttons.

- Return to the initial value by pressing the (+) and (-) buttons simultaneously (approx. 1 sec).

#### 2 (Setting the external power supply voltage alarm)

Select the setting item "LIMT" by moving the (JOG) button up or down, and set the voltage at which the alarm begins to sound with the (+) button or (-) button.

When finished with the setting, return to the TELEMETRY screen by pressing the (END) button.





### (Current drive battery capacity )

Select the setting item "CAPACITY" by moving the (JOG) button up or down, and display the external power supply capacity screen by pressing the (JOG) button.

#### 1 (Setting of each item)

Select the setting item "ALRM" by moving the (JOG) button up or down., and set alarm ON/OFF with the (+) button or (-) button.

"OFF": Alarm OFF.

"ON": Alarm ON by a voltage drop below the specified voltage.

#### 2 (Setting the external power supply capacity alarm)

Select the setting item "LIMT" by moving the (JOG) button up or down, and set the capacity at which the alarm begins to sound with the (+) button or (-) button.

When finished with the setting, return to the TELEMETRY screen by pressing the (END) button.

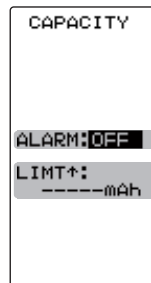

#### Alarm ON/OFF

ON, OFF

- Select with the (+) or (-) buttons.

#### Capacity alarm

- Adjust with the (+) and (-) buttons.

- Return to the initial value by pressing the (+) and (-) buttons simultaneously (approx. 1 sec).

## Telemetry information display settings

In the "DISP" setting of the system menu ([page 42](#)), one of three types of telemetry information can be selected and displayed on the HOME screen. The modes that can be selected will change according to the "MODE" setting of "Telemetry function ON / OFF" on [page 133](#).

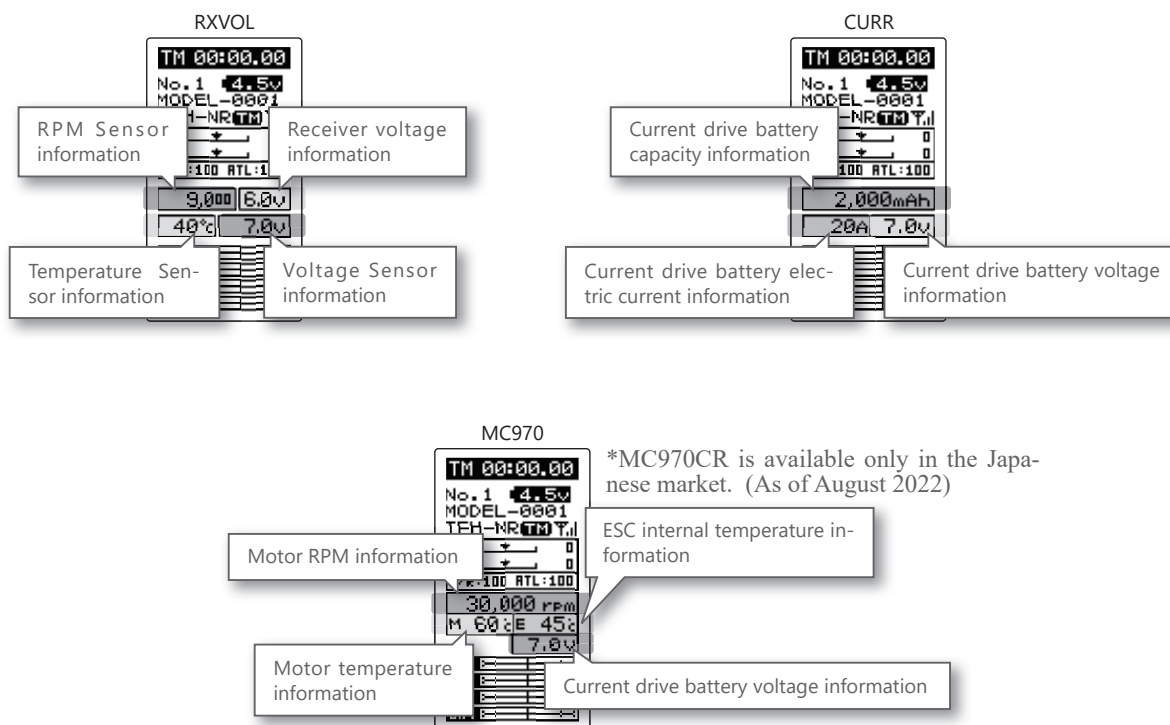

## Log Setting Start/Stop

The data from a telemetry sensor can be saved to the T4PM PLUS as a data log. Since the data is sequentially updated, when data logging is performed, the old data is erased. Only one set of data is saved.

The interval at which the data is acquired can be selected from a minimum 0.1 second to a maximum 60 seconds. Because the maximum count is 100, if 100 counts are made at 0.1 second intervals, 10 seconds worth of data is acquired. If 100 counts are made at 60 second intervals, 1 hour 40 minutes worth of data is acquired.

Data logging is started and stopped by setting SW2 using the select switch function ([page 106](#)) to "LOGGER" and by switch. If the switch is not set, data logging is started by throttle trigger from the log setting screen.

Data logging can also be started by throttle trigger from this screen and stopped by switch set by select switch function.

Display "LOG MODE" screen by the following method:

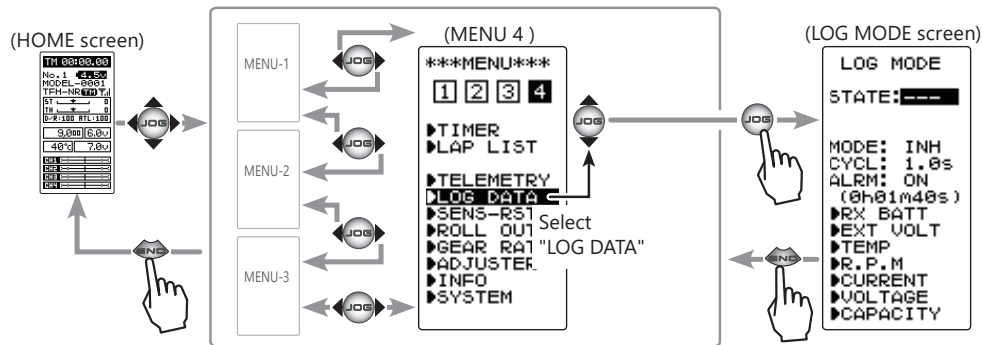

### Log setting method

(Preparation)

When using a switch to start and stop data logging, set SW2 to "LOGGER" by the function select switch ([page 106](#)).

#### 1 (Log function ON/OFF)

Move the cursor to the "MODE" setting item by moving the (JOG) button, and turn on the log function by setting "MODE" to "ACT" by pressing the (+) button or (-) button.

If "MODE" is not set to "ACT", the log function will not be performed even if the switch, etc. is operated.

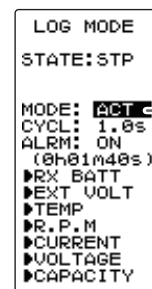

Function ON/OFF (MODE)

INH, ACT

Select button

- Select with the (+) or (-) buttons.

"INH": Function OFF.

"ACT": Function ON.



**2** (Recording cycle setting)  
 Select the setting item "CYCL" by moving the (JOG) button up or down, and set the data acquisition interval from a minimum 0.1 second to a maximum 60 seconds with the (+) button or (-) button.  
 The maximum recordable time set by CYCL is displayed at END TIME shown below.

**3** (Count alarm ON/OFF)  
 Select the setting item "ALRM" by moving the (JOG) button up or down. To sound an electronic beep at each log count, set "ALRM" to ON with the (+) button or (-) button.  
 "OFF": Alarm OFF.  
 "ON": Alarm ON at each log count.

When finished with the setting, return to the MENU screen by pressing the (END) button.

```
LOG MODE
STATE:STP
MODE: ACT
CYCL: 1.0s
ALRM: ON
(0h01m40s)
▶RX BATT
▶EXT VOLT
▶TEMP
▶R.P.M
▶CURRENT
▶VOLTAGE
▶CAPACITY
```

**Log recording cycle**  
 0.1 ~ 60s (sec)  
 0.1 ~ 10s (sec) 0.1s step  
 10s ~ 60s (sec) 1s step  
 Initial value: 1.0sec  
**Adjust button**  
 - Adjust with the (+) and (-) buttons.  
 - Return to the initial value by pressing the (+) and (-) buttons simultaneously (approx. 1 sec).

**Log recording time**  
 10s (seconds) ~ 1h 40m  
 (1 hours 40 minutes)  
 The maximum recordable time set by CYCL is displayed automatically.

```
LOG MODE
STATE:STP
MODE: ACT
CYCL: 1.0s
ALRM: ON
(0h01m40s)
▶RX BATT
▶EXT VOLT
▶TEMP
▶R.P.M
▶CURRENT
▶VOLTAGE
▶CAPACITY
```

**Alarm ON/OFF**  
 ON, OFF  
 - Select with the (+) or (-) buttons.

**Log function start/stop operation**

**1** (Log start operation)  
**-Start by switch (SW2)**  
 When the switch (SW2) set by select switch function ([page 106](#)) is pressed, data logging starts.

**-Starting by throttle trigger**  
 Display the log setting "LOG MODE" screen and select the "STATE" setting item by the (JOG) button operation. Press the (JOG) button for approximately 1 second.

An electronic beeping sound is generated and the "STATE" display switches from "RST" to blinking "RDY", and the logger enters the trigger operation waits state. When the trigger is operated in the forward direction, data logging begins. (STATE display "STA") When the end time arrives, an electronic beep sounds and data logging stops. Return to the MENU screen during data logging by pressing the (END) button.

```
LOG MODE
STATE:STP
( →RDY)
MODE: ACT
CYCL: 1.0s
ALRM: OFF
(0h01m40s)
▶RX BATT
▶EXT VOLT
▶TEMP
▶R.P.M
▶CURRENT
▶VOLTAGE
▶CAPACITY
```

**Status display**  
 RDY: Throttle trigger operation waits  
 STA: Logger running  
 STP: Logger stopped

**2** (Log forced end)  
 To abort logging, press the switch (SW2), the same as starting, or display the log setting "LOG MODE" screen and select the "STATE" setting item moving the (JOG) button operation. Then press the (JOG) button for approximately 1 second. An electronic beeping sound is generated and logging is stopped.

# Log Data List

The log data list can be called when checking the log data memorized by logging operation ([page 138](#)). The maximum log data is up to 100 counts.

## Example: Receiver power supply voltage log list screen.

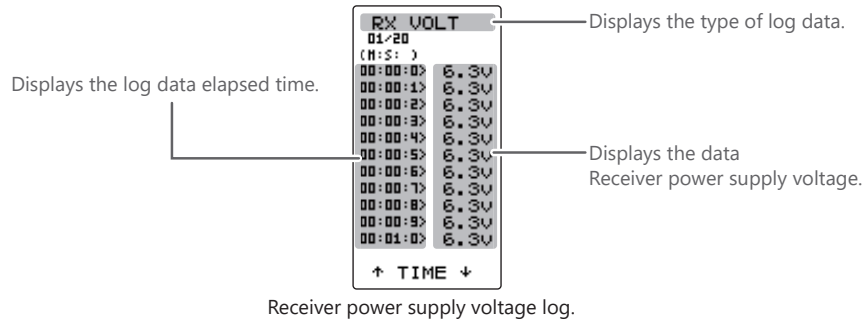

Log list screen.

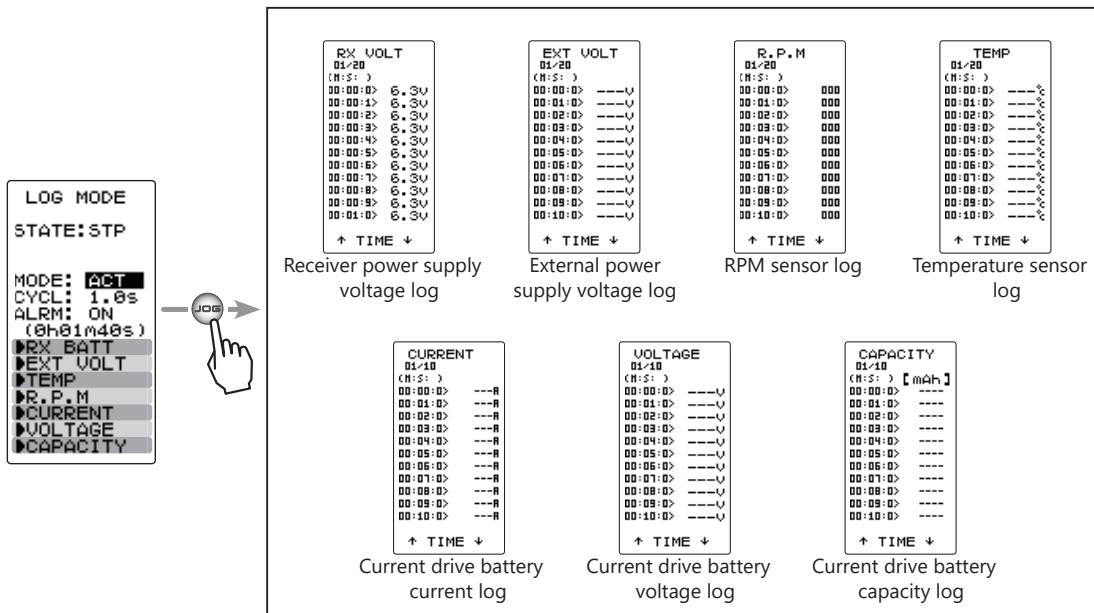

### Log list check method

- 1 (Log memory check)  
Each time the (JOG) button is operated up or down the list is scrolled 10 counts and each log data can be checked up to 100 counts.
- 2 To return to the LOG screen by pressing the (END) button.

## Resets the sensor slot number "SENS-RST"

This function is to reset the sensor slot number when using a sensor whose slot number has been changed by another transmitter. Connect the sensor as shown and register according to the following procedure.

### Sensor connect

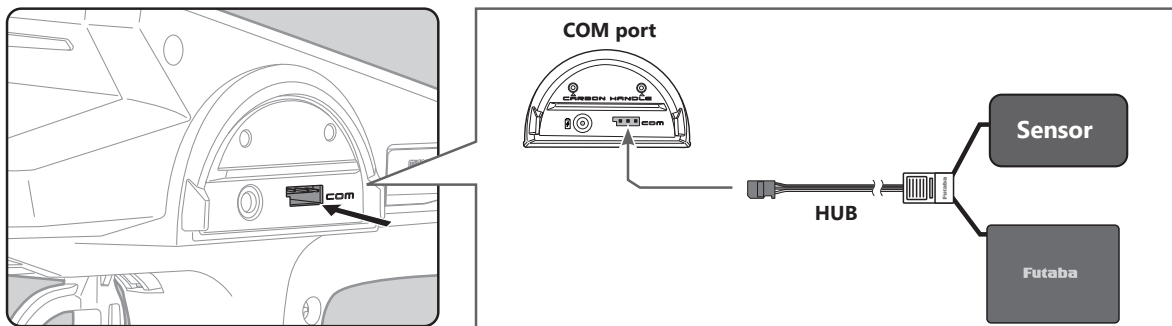

Display "SENS RST" screen by the following method:

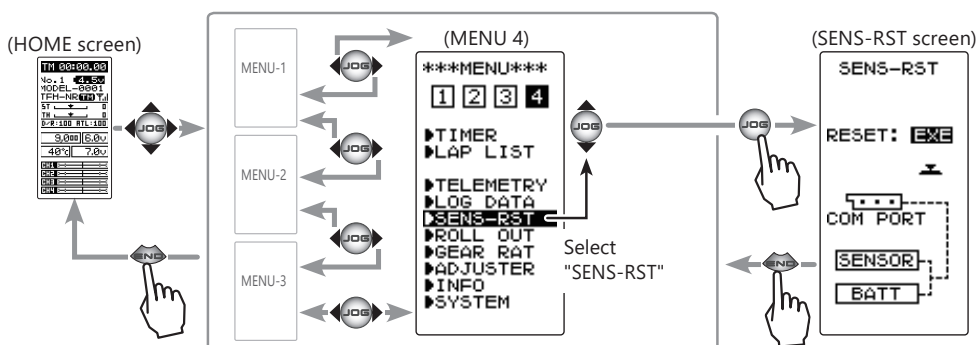

### How to reset sensor slot number

#### 1 (Execute reset)

Press the (JOG) button for about 1 second.

- "COMPLETE!" blinks on the screen and reset sensor slot number.
- If "COM-ERROR" blinks on the screen, communication with the sensor is not being performed normally. Check the T4PM PLUS and sensor connection and the battery connection to sensor and repeat RE-SET.



**Execute reset**  
Press the (JOG) button for approximately 1 second.

#### 2 When finished with the setting, return to the MENU screen by pressing the (END) button.



# Roll Out Chart "ROLL OUT"

This function is designed for pan cars. The roll out chart can be calculated from input values for the number of teeth of the spur gear and pinion gear, and the tire diameter, and displayed as a table.

Display "SENS RST" screen by the following method:

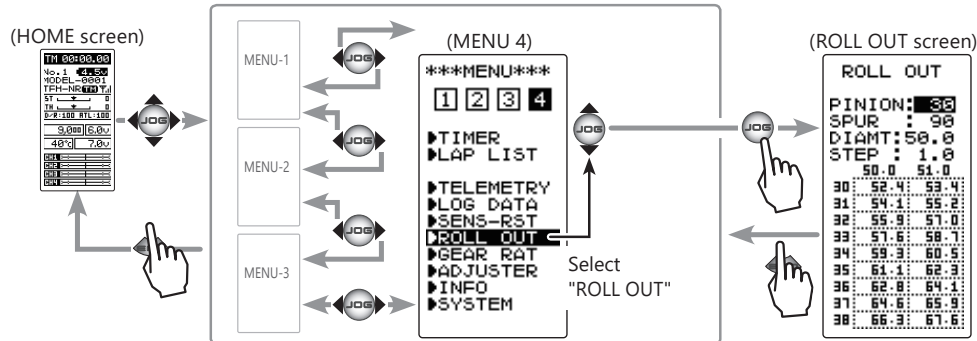

## Use of Roll out chart function

- 1 (Setting of step of the tire diameter input)  
Select the setting item "STEP" by moving the (JOG) button up or down. Use the (+) and (-) buttons to set the step of input numerical value of tire diameter amount.

-The step amount can be set in the range of 0.1 mm to 1.0 mm.

- 2 (Setting of number of teeth of spur gear)  
Select the setting item "SPUR" by moving the (JOG) button up or down. Use the (+) and (-) buttons to set the spur gear. The roll out is then calculated, and the list is updated.

ROLL OUT		
PINION:	30	
SPUR :	90	
DIAMT:	50.0	
STEP :	1.0	
	50.0	51.0
30:	52.4	53.4
31:	54.1	55.2
32:	55.9	57.0
33:	57.6	58.7
34:	59.3	60.5
35:	61.1	62.3
36:	62.8	64.1
37:	64.6	65.9
38:	66.3	67.6

### Adjustment buttons

- Use the (+) and (-) buttons to make adjustments.
- Return to the initial value by pressing the (+) and (-) buttons simultaneously (approx. 1 sec).

- 3 (Setting of number of teeth of pinion gear)  
Select the setting item "PINION" by moving the (JOG) button up or down. Use the (+) and (-) buttons to set the pinion gear. The roll out is then calculated, and the list is updated.

- 4 (Setting of tire diameter)  
Select the setting item "DIAMT" by moving the (JOG) button up or down. Use the (+) and (-) buttons to set the tire diameter. The roll out is then calculated, and the list is updated.

- 5 When finished with the setting, return to the MENU screen by pressing the (END) button.

# Gear Ratio Chart "GEAR RAT"

The Gear Ratio Chart can be calculated from input values for the number of teeth of the spur gear and pinion gear, and secondary gear ratio, and displayed as a table.

Display "SENS RST" screen by the following method:

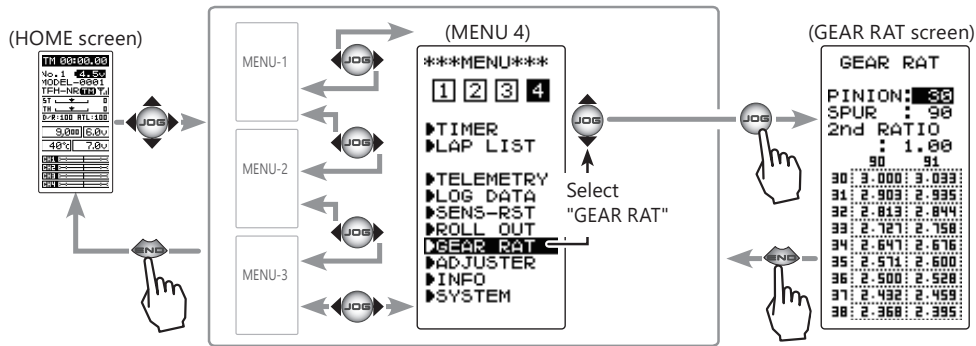

## Use of Gear ratio chart function

- 1** (Setting of number of teeth of pinion gear)  
 Select the setting item "PINION" by moving the (JOG) button up or down. Use the (+) and (-) buttons to set the pinion gear. The roll out is then calculated, and the list is updated.
- 2** (Setting of number of teeth of spur gear)  
 Select the setting item "SPUR" by moving the (JOG) button up or down. Use the (+) and (-) buttons to set the spur gear. The roll out is then calculated, and the list is updated.
- 3** (Setting of number of secondary gear ratio)  
 Select the setting item "2nd RATIO" by moving the (JOG) button up or down. Use the (+) and (-) buttons to set the 2nd gear ratio. The roll out is then calculated, and the list is updated.
- 4** When finished with the setting, return to the MENU screen by pressing the (END) button.

GEAR RAT		
PINION:	30	
SPUR :	90	
2nd RATIO	: 1.00	
	90	91
30:	3.000	3.033
31:	2.903	2.935
32:	2.813	2.844
33:	2.721	2.758
34:	2.641	2.676
35:	2.571	2.600
36:	2.500	2.528
37:	2.438	2.459
38:	2.368	2.395

### Adjustment buttons

- Use the (+) and (-) buttons to make adjustments.
- Return to the initial value by pressing the (+) and (-) buttons simultaneously (approx. 1 sec).

# Adjuster "ADJUSTER"

Steering wheel and throttle trigger neutral position and servo operating angle correction can be applied. This is used when a mechanical offset has occurred for some reason.

\*However, when correction is made, the set value of all the setting functions must be re-checked.

Display the "ADJUSTER" screen using the following method:.

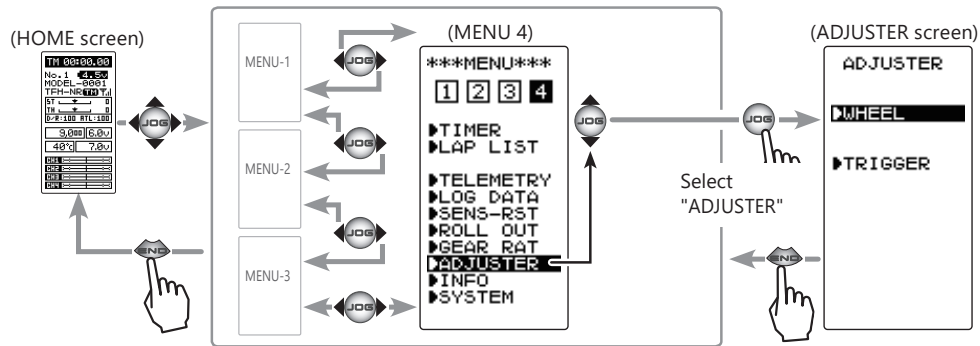

## Steering adjustment

(Preparation)

On the ADJUSTER screen, select the setting item "WHEEL" by moving the (JOG) button up or down, and press the (JOG) button.

### 1 (Steering neutral adjustment)

In the neutral setup screen (fig-1) state, lightly pull the steering wheel and then press the (JOG) button without touching the wheel.

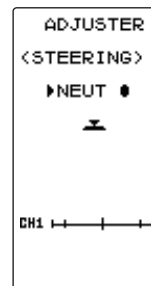

fig-1

### 2 (Steering throw adjustment)

In the throw setup screen state (fig-2), lightly turn the wheel fully to the left or right and when button mark (fig-3) is displayed, press the (JOG) button.

Internal check is performed automatically. When each adjustment point is within a fixed range, correction is performed and "COMPLETE" (fig-4) is displayed.

If an adjustment point is not within a fixed range, correction is not performed and the correction data is not updated.

When button mark is not displayed even though correction was performed again, please contact a Futaba Radio Control Customer Center.

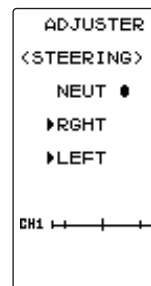

fig-2

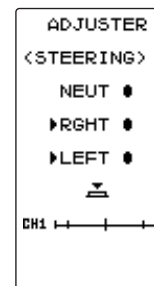

fig-3

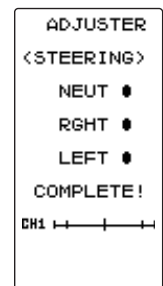

fig-4

### 3 When finished with the setting, return to the ADJUSTER screen by pressing the (END) button.



## Throttle adjustment

(Preparation)

On the ADJUSTER screen, select the setting item "THROTTLE" by moving the (JOG) button up or down, and press the (JOG) button.

### 1 (Throttle neutral adjustment)

In the neutral setup screen (fig-1) state, lightly pull the throttle trigger and then press the (JOG) button in without touching the trigger.

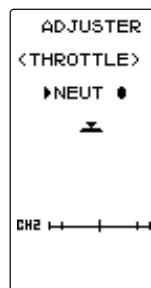

fig-1

### 2 (Throttle throw adjustment)

In the throw setup screen state (fig-2), lightly operate the trigger fully to the brake side and the forward side and when button mark (fig-3) is displayed, press the (JOG) button.

Internal check is performed automatically. When each adjustment point is within a fixed range, correction is performed and "COMPLETE!" (fig-4) is displayed.

If an adjustment point is not within a fixed range, correction is not performed and the correction data is not updated.

When button mark is not displayed even though correction was performed again, please contact a Futaba Radio Control Customer Center.

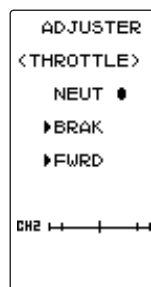

fig-2

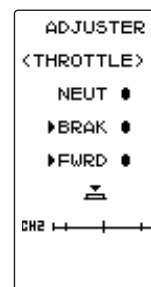

fig-3

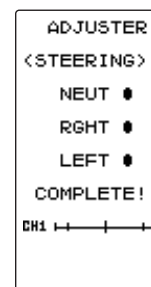

fig-4

### 3 When finished with the setting, return to the ADJUSTER screen by pressing the (END) button.



# Information "INFO"

Display version of T4PM PLUS program, ID information.

Display the "INFO" screen using the following method:.

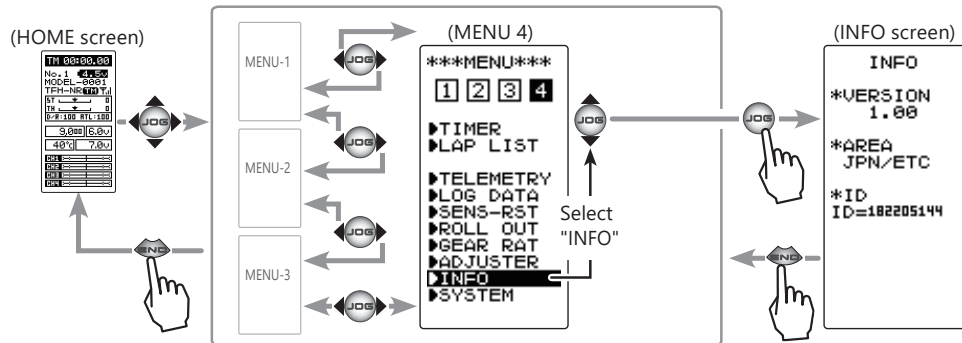

## Software Update

Whenever improvements and new functions are available, the software of your T4PM PLUS radio transmitter can be updated easily online free of charge. The zip file of the update data will be shown on our website. You can download it and make a copy on your microSD card.

Below is the procedure for the software update.

**Caution:** Before you update the software, the battery that is connected to the T4PM PLUS should be fully charged.

### Update method

- 1 Extract the zip file on your computer. The "FUTABA" folder will be created on your computer and copy the "FUTABA" folder onto your microSD card.

**Note:** If the microSD card has already had "another FUTABA" folder before you make a copy, the "FUTABA" folder is OVERWRITTEN.

- 2 Insert the microSD card with "FUTABA" folder that contained the update software into the SD card slot on your the T4PM PLUS.

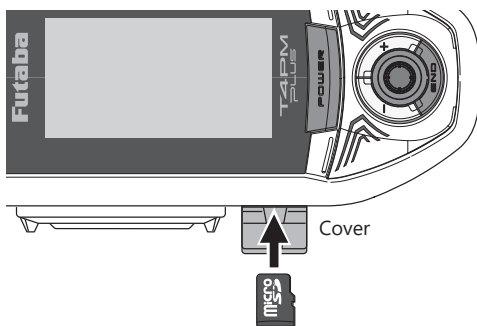

- \*Insert the card with the metal terminals side at the bottom.
- \*Remove the card by pushing it in and then pulling it out.
- \*Install and remove the card by pushing it in until you hear a click.

#### (Commercial product)

SD standard and SDHC standard microSD cards SD/SDHC format. Maximum size 32GB.  
(Some models may not be operated by card.)  
SDXC format is not supported.



\*The data in the memory card cannot be guaranteed regardless of the contents and cause of trouble or damage. Always back-up the valuable data in the memory card.

- 3 Turn on the T4PM PLUS power while pressing down the "END" button. The software update is started.

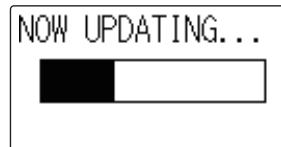

- 4 When the software update is completed, "SUCCESS" message is shown on the LCD display of your T4PM PLUS.

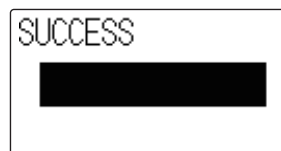

- 5 Turn off the power switch of your T4PM PLUS and remove the microSD card from the card slot.

### Caution

- ⓘ Always insert and remove the microSD card in the state in which the transmitter power is off.  
If the microSD card is removed while being accessed (read or write), the card itself and the data may be destroyed.
- ⊘ Do not install and remove the microSD card with the microSD card slot facing your face.  
If you remove your fingers quickly, the microSD card may fly out and strike your face and is dangerous.
- ⊘ Since the microSD card is a precision device, do not subject it to unreasonable force or shock.

## Ratings

\*Specifications and ratings are subject to change without prior notice.

**Maximum operating range: 100m (Except the MINIT system) (Optimum condition)**  
**For safety: F/S, B-F/S, ID**

### Transmitter T4PM PLUS

(T-FHSS SR / T-FHSS/S-FHSS system, wheel type, 4 channels)

**Transmitting frequency band:**

2.4GHz band

**RF power output:**

100mw EIRP

**Power requirement:**

(Dry cell battery) Penlight x 3 (4.5V)

**Current drain:**

150mA or less

**Transmission antenna:**

1/2λ di-pole

**Receiver R304SB / R304SB-E:** (T-FHSS system, 4 channels)

**Receiver R334SBS / R334SBS-E:** (T-FHSS/T-FHSS SR system, 4 channels)

**Power requirement:**

4.8V~7.4V battery / 3.5 ~ 8.4V useable (Dry cell battery cannot be used.)

**Receiving frequency band:**

2.4GHz band

**RF power output:**

10mw EIRP

**System:**

T-FHSS system (auto detection)

**Size:** (excluding a projection part)

R304SB / R304SB-E: 1.38x0.91x0.33" (35.1x23.2x8.5mm)

R334SBS / R334SBS-E: 1.33x0.88x0.44" (33.9x22.3x11.3mm)

**Weight:**

R304SB/R304SB-E: 0.23oz. (6.6g)

R334SBS: 0.26oz. (7.5g)/ R334SBS-E: 0.25oz. (7.2g)

### System Compatibility

The T4PM PLUS is a 2.4GHz T-FHSS SR / T-FHSS surface system. The transmitter can also be switched to S-FHSS. The usable receivers are shown below. (However, the telemetry system cannot be used with T-FHSS SR and S-FHSS.)

Communications System	Usable Receivers
<b>T-FHSS (Default)</b>	<b>R304SB / R304SB-E</b> <b>R314SB / R314SB-E / R324SBS</b> <b>R334SBS / R334SBS-E</b> *R3008SB, T-FHSS Air system receivers do not operate.
<b>T-FHSS SR (Change is possible)</b>	<b>R334SBS / R334SBS-E</b>
<b>S-FHSS (Change is possible)</b>	<b>R203GF / R2104GF / R204GF-E</b>

**NOTE:**

The T-FHSS surface system and T-FHSS Air system are different. The T4PM PLUS cannot be used with the R3008SB or T-FHSS Air system receivers.



# Warning Displays

## Low Battery Alarm

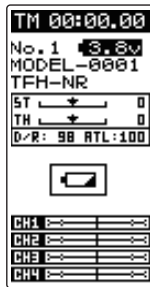

(HOME screen)

### LCD screen:



(MENU 1, 2, 3, 4 screen)

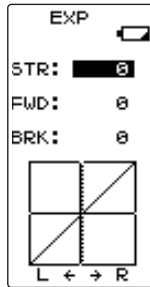

(Function screen)

When the battery voltage of the transmitter falls below the usable range, an audible alarm will sound and "  " will be displayed on the LCD screen.

**Audible alarm:**  
Continuous tone.

## Warning

**!** When a low battery alarm is generated, cease operation immediately and retrieve the model. If the battery goes dead while in operation, you will lose control.

### Power supply and low battery alarm

The T4PM PLUS can use an optional rechargeable battery. However, the battery alarm setting is different from that of the dry cell battery (alkaline battery recommended). Therefore, always set the battery type to match the power source used. Always set the battery type to "LiFe2" especially when using a Futaba rechargeable type battery. If the set is used at "DRY3" setting, the time from low battery alarm to system stopping will become extremely short. (See page 43, for a detailed description of the battery types.)

## Memory Error

### LCD screen:

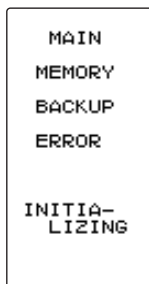

If the data in the transmitter is not transferred normally when the power is turned on, an audible alarm will sound and "MAIN MEMORY BACKUP ERROR" will be displayed on the LCD. When a memory error is generated, request repair from the Futaba Service Center.

- To stop the alarm, turn off the power.

**Audible alarm:**  
Tone sounds (7 times) and stops (repeated)



### LCD screen:

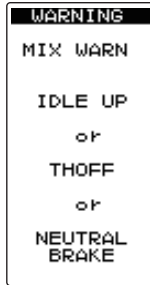

When the power switch is turned on while the idle-up, preset (engine cut) or neutral brake function switch is on, an audible alarm will sound and "MIX WARN" will be displayed on the LCD. When that function switch is turned off, the alarm will stop.

#### Audible alarm:

**Tone sounds (7 times) and stops (repeated)**

## Power off reminder

### LCD screen:

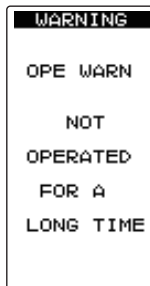

If the T4PM PLUS is not operated for 10 minutes, an audible alarm is sounded and "OPE WARN" is displayed on the screen. The audible alarm stops when the steering wheel, throttle trigger, and any dial, switch, or edit button is operated. If you are not going to use the transmitter, turn the power off. (Setting can be reset at the system menu on [page 44](#).)

#### Audible alarm:

**Tone sounds (7 times) and stops (repeated)**



# Warranty & Repair Service (In U.S.A)

## (Warranty)

Read the Warranty card.

- When requesting warranty service, send the card or some type of dated proof purchase.

Technical updates and additional programming examples can be found at: [www.futabausa.com](http://www.futabausa.com)

## (Information needed for repair)

If any difficulties are encountered while setting up or operating your T4PM PLUS, please consult the instruction manual first. For further assistance you may also refer to your hobby dealer or contact the Futaba Service Center at the e-mail address, fax or telephone number listed below:

Phone:1-256-461-9399, FAX:1-256-461-1059

E-Mail: [contactus@futaba.com](mailto:contactus@futaba.com)

If you are unable to resolve the issue, pack the system in its original container with a note enclosed and a thorough, accurate description of the difficulty. Include the following in your note:

- Symptoms (including when the problem occurred)
  - System (Transmitter, Receiver, Servos and model numbers)
  - Model (Model name)
  - Your Name, Address and Telephone number
- 
- No part of this manual may be reproduced in any form without prior permission.
  - The contents of this manual are subject to change without prior notice.
  - This manual has been carefully written. Please write to Futaba if you feel that any corrections or clarifications should be made.
  - Futaba is not responsible for the use of this product.

---

**©Copyright 2022. No part of this manual may be reproduced in any form without prior permission. The contents of this manual are subject to change without prior notice. While this manual has been carefully written, there may be inadvertent errors or omissions. Please contact our service center if you feel that any corrections or clarifications should be made.**

FUTABA CORPORATION  
Hobby Radio Control Business Center Sales & Marketing Department  
1080 Yabutsuka, Chosei-mura, Chosei-gun, Chiba-ken, 299-4395, Japan  
TEL: +81-475-32-6051, FAX: +81-475-32-2915

**T4PM  
PLUS**

<https://futabausa.com>

<https://www.rc.futaba.co.jp>

**Futaba®**