

**Futaba®**

*Flybarless Control Gyro*

**CGY760R**

Gyro Program Box

**GPB-1**

**INSTRUCTION MANUAL**

1M23N33702

CE



## INTRODUCTION

---

Futaba CGY760R is receiver, 3-axis Stabilization System combining AVCS gyro and head speed governor in one box designed for flybarless helicopters. Its cutting-edge MEMS (Micro Electro Mechanical System) sensor design, ultra high-speed processing speed, and advanced PID control algorithm put it a league of it's own ahead of all ahead of all other heading hold gyros in size, weight and performance.

*Flybarless Control Gyro*  
**CGY760R**

Gyro Program Box

**GPB-1**

**INSTRUCTION MANUAL**

- 
- No part of this manual may be reproduced in any form without prior permission.
  - The contents of this manual are subject to change without prior notice.
  - This manual has been carefully written. Please write to Futaba if you feel that any corrections or clarifications should be made.
  - Futaba is not responsible for the use of this product.

### **Compliance Information Statement (for U.S.A.)**

This device, trade name Futaba Corporation, model number CGY760R, complies with part15 of the FCC Rules. Operation is subject to the following two conditions:

- (1) This device may not cause harmful interference, and
- (2) This device must accept any interference received, including interference that may cause undesired operation.

CAUTION: To assure continued FCC compliance

1. Any changes or modifications not expressly approved by the grantee of this device could void the user's authority to operate the equipment.
2. This equipment complies with FCC radiation exposure limits set forth for an uncontrolled environment.

This equipment should be installed and operated with minimum distance 20cm between the radiator & your body.

The responsible party of this device compliance is:

Futaba Service Center

2681 Wall Triana Hwy Huntsville, AL 35824, U.S.A.

TEL 1-256-461-9399 or E-mail: [service@futabaUSA.com](mailto:service@futabaUSA.com)

### **Compliance Information Statement (for Canada)**

This device complies with Industry Canada license-exempt RSS standard(s). Operation is subject to the following two conditions: (1) this device may not cause interference, and (2) this device must accept any interference, including interference that may cause undesired operation of the device. This equipment complies with IC radiation exposure limits set forth for an uncontrolled environment. This equipment should be installed and operated with minimum distance 20cm between the radiator & your body.

French: Cet appareil radio est conforme au CNR-210 d'Industrie Canada. L'utilisation de ce dispositif est autorisée seulement aux deux conditions suivantes : (1) il ne doit pas produire de brouillage, et (2) l'utilisateur du dispositif doit être prêt à accepter tout brouillage radioélectrique reçu, même si ce brouillage est susceptible de compromettre le fonctionnement du dispositif. Cet équipement est conforme aux limites d'exposition aux rayonnements IC établies pour un environnement non contrôlé.

Cet équipement est conforme aux limites d'exposition aux rayonnements IC établies pour un environnement non contrôlé. Cet équipement doit être installé et utilisé avec un minimum de 20 cm de distance entre la source de rayonnement et votre corps.

### **Declaration of Conformity (for EU)**

Hereby, Futaba Corporation declares that the radio equipment type is CGY760R in compliance with Directive 2014/53/EU. The full text of the EU declaration of conformity is available at the following internet address:

<http://www.rc.futaba.co.jp/english/dl/declarations.html>



# TABLE OF CONTENTS

• Introduction -----	2
• Warranty and Repair Service (in U.S.A.)-----	5
• Features -----	6
• Contents -----	8
• Replacement and Optional Items -----	10
• Precautions -----	11
• Mounting / Part name / Connecting -----	17
Mounting the CGY760R -----	18
Link Method With Transmitter (FASSTest / T-FHSS)-----	21
Connecting The CGY760R -----	22
S.BUS Channel Setting -----	24
Governor Installation-----	24
• First Map-----	28
• Home Screen-----	30
• GPB-1 Screen-----	33
• BASIC MENU-----	39
• SBUS BASIC MENU (S.BUS Basic Setting) -----	40
• SWH. BASIC MENU (Swash Basic Setting)-----	44
• FLT. TUNE MENU (Flight Tuning Setting)-----	52
• RUD. BASIC MENU (Rudder Gyro Basic Setting) -----	56
• GOV. BASIC MENU (Governor Basic Setting) -----	60
Governor Speed Setting -----	67
Governor Operation -----	67
• Recommended Gyro Gain Setting -----	68
• Adjustments During The Test Flight -----	68
• Tips Using The Governor With Electric Models -----	70
• TRANSMITTER Rotor head Gyro GAIN SET-UP -----	71
• EXPERT MENU-----	72
• RUD. EXPERT MENU (Rudder Gyro Expert Setting) -----	73
• FLT. EXPERT MENU (Cyclic Gyro Expert Setting) -----	77
• SWH. DETAIL MENU (Swash Detail Setting) -----	80
• GOV. EXPERT MENU (Governor Expert Setting) -----	87
• 3D VIA TRAINER Screen FUNCTIN LIST -----	91
• MOUNTING OF CGY760R WITH SCREWS -----	92
• Specifications -----	93

**Gyro** : Instructions for gyro functions

**Governor** : Instructions for governor functions

**Technical updates and additional programming examples can be found at: [www.futabausa.com](http://www.futabausa.com)**

 **WARRANTY & REPAIR SERVICE (IN U.S.A.)**

If any difficulties are encountered while setting up or operating your CGY760R, please consult the instruction manual first. For further assistance you may also refer to your hobby dealer or contact the Futaba Service Center at the e-mail address, fax or telephone number listed below:

**Phone:1-256-461-9399, FAX:1-256-461-1059**  
**E-Mail: [service@futabaUSA.com](mailto:service@futabaUSA.com)**

If you are unable to resolve the issue, pack the system in its original container with a note enclosed and a thorough, accurate description of the difficulty. Include the following in your note:

- Symptoms (including when the problem occurred)
- System (Transmitter, Receiver, Servos and model numbers)
- Model (Model name)
- Your Name, Address and Telephone number

Send the respective items to the authorized Futaba Service Center Address below:

**Futaba Corporation of America**  
**2681 Wall Triana Hwy**  
**Huntsville, AL 35824, U.S.A.**



## FEATURES

---

- Combined Receiver, 3-Axis Gyro and Governor in one box.
- High speed operation and extremely low latencies result in greater stability.
- Low profile, small size, and light weight.
- Easy set-up and tuning the gyro and governor program using the GPB-1.
- Settings divided into Basic and Expert menus. The basic setting is for initial setting and Expert setting is for more advanced settings.
- Firmware can be updated from a Windows based personal computer when used with the optional CIU-2 or CIU-3 interface.
- S.BUS 2 compatible.

### • Gyro section

- Advanced and adaptive PID control loop is utilized.
- Simultaneous control of 3 axes (roll, pitch, yaw).

#### **Rudder (yaw) section:**

- Capable of sensing angular velocity up to +/- 1,000 deg/sec.
- Compatible with 1520 $\mu$ S Analog (70Hz), 1520 $\mu$ S Digital (280Hz), and 760 $\mu$ S Digital (560Hz) tail rotor servos.
- Feed Forward Option allows the CGY760R to consider other control functions during operation. This results in more accurate corrections and precise operation.
- Cutting edge control algorithm provides a consistent pirouette rate, precise operation, and smooth yaw control in any flight condition.

#### **Aileron, Elevator (roll, pitch) section:**

- Developed specifically for flybarless helicopters.
- Supports H3-120, H3-140, H3-90, H4-00, and H4-45 swash plate types.

### • Governor section

- Advanced and adaptive PID control loop is utilized.
- High speed operation and extremely low latencies provide a more consistent and accurate operation.
- Capable of governing head speeds from 700 RPM through 4000 RPM
- Compatible with 1520 $\mu$ S Analog (70Hz) and 1520 $\mu$ S Digital (280Hz) throttle servo types.
- Feed Forward Option allows the CGY760R to consider other control functions

during operation. This results in precise governing of the head speed.

- Governor or Revolution Limiter mode selectable.
- Supports gear ratios from 1.00 through 50.00.
- Cutting edge control algorithm provides more consistent RPM governing.
- Revolution sensor is compatible with the GV-1. The CGY760R also supports an optional back plate revolution sensor and brushless phase sensor.

- **Receiver section**

- Switch FASSTest - 2.4 GHz system and T-FHSS - 2.4 GHz system using the Gyro Program Box GPB-1 system.
- By S.BUS 2 system compatibility, it is possible to transmit the battery voltage information of the receiver and the optional sensor information connected to the S.BUS 2 port of the receiver.
- Diversity antenna system.

- **Other functions**

- Maximum RPM memory.
- Cumulative engine operation timer.
- Integration function of engine operation time.



# CONTENTS

Your CGY760R includes the following components:

## Type of set

- CGY760R / GPB-1 / Governor set
- CGY760R / GPB-1 set
- CGY760R
- GPB-1

<b>SET CONTENTS</b>				
<b>GPB-1 Program Box</b>				
*CGY760R connection cable	X	---	X	X
*Transmitter connection cable				
*Velcro tape (for attaching to transmitter)				
<b>CGY760R</b>				
*Mounting Pads (x3)	---	X	X	X
*Dust Covers (x3)				
<b>Governor Sensor</b>				
*Sensor Mounting Bracket	---	---	---	X
*Magnet (x2)				
<b>Instruction Manual</b>	X	X	X	X
<b>Decal</b>	X	X	X	X

**X: supplied    ---: not supplied**



## GPB-1 Gyro Program Box

When setting up the gyro and the governor, connect it to the CGY760R and use it. Do not install it on the helicopter.



**CGY760R**



**Mounting Pads (3)**

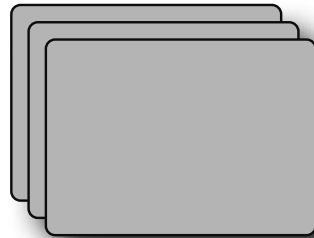

**Revolution Sensor**



**Sensor Mounting Bracket**

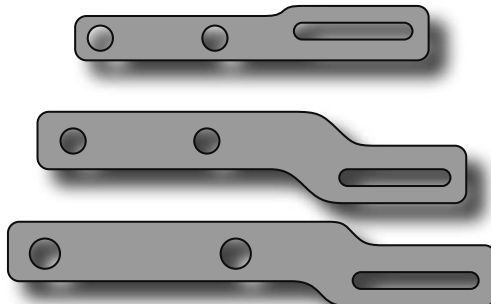

**Magnets (2)**



### **CGY760R Connection Cord**

It is used to connect the CGY760R and the Gyro Program Box GPB-1.



### **Transmitter Connection Cord**

It is used to connect the transmitter to the Gyro Program Box GPB-1 and use the transmitter to transfer the settings of GPB-1 to the CGY760R wirelessly.



### **Dust Cover (3)**



## **REPLACEMENT & OPTIONAL ITEMS**

---

-----  
**Futaba PC Interface CIU-2 / CIU-3**  
-----

-----  
**Governor Revolution Sensor Set**  
-----

-----  
**Mounting Pad (10)**  
-----

-----  
**Sensor Mounting Bracket Set**  
-----

-----  
**Backplate Sensor BPS-1**  
-----

# PRECAUTIONS

## *Meaning of Special Markings*

Pay special attention to safety where indicated by the following marks:

**⚠ DANGER** - Procedures which may lead to dangerous conditions and cause death/serious injury if not carried out properly.

**⚠ WARNING** - Procedures which may lead to a dangerous condition or cause death or serious injury to the user if not carried out properly or procedures where the probability of superficial injury or physical damage is high.

**⚠ CAUTION** - Procedures where the possibility of serious injury to the user is small, but there is a danger of injury, or physical damage, if not carried out properly.

 : Prohibited     : Mandatory

## **⚠ WARNING**

**Failure to follow these safety precautions may result in severe injury to yourself and others.**

- Read through the entire manual before operating this product.

## **USAGE PRECAUTION:**

\* When using FASSTest 12 CH mode, analog servo can not be used for 1-6 CH output for conventional system.

\* The FASSTest system is not compatible with the conventional FASST system.

## **⚠ CAUTION**

**⊘ Do not mount GPB-1 (Gyro Program Box) on the helicopter.**

\* It will be damaged by vibration.

## **ANTENNA INSTALLATION PRECAUTION:**

### **⚠ WARNING**

**ⓘ Be sure that the two antennas are placed at 90 degrees to each other.**

\*The CGY760R has two antennas. In order to maximize signal reception and promote safe modeling Futaba has adopted a diversity antenna system. This allows the receiver to obtain RF signals on both antennas and fly problem-free.

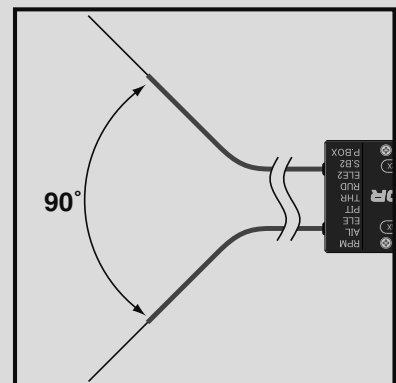

- ⊘ Do not cut or bundle the receiver antenna wire.
- ⊘ Do not bend the coaxial cable. It causes damage.
- ⊘ To prevent damage to the antenna, please exercise caution. Do not bend at the base of the antenna. Also, ensure that the unit is not subjected to impact damage.
- ⓘ Keep the antenna as far away from the motor, ESC and other noise sources as you possibly can.

### CARBON FUSELAGE PRECAUTION:

#### ⚠ WARNING

- ⓘ You must leave 30mm at the tip of the antenna fully exposed. The exposed antenna should be secured so that it can not move around or back inside of your aircraft.

### CONNECTOR INSERTION PRECAUTION:

#### ⚠ WARNING

- ⊘ Do not connect the connector by mistake as shown on the right.

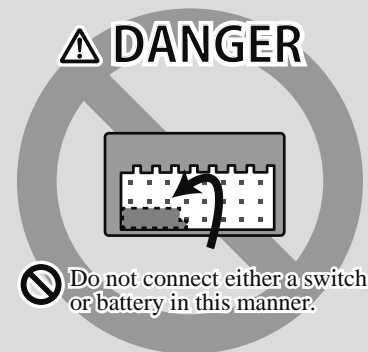

### BEFORE EACH FLIGHT:

#### ⚠ WARNING

- ⓘ Keep away from conductive materials to avoid short circuits.
- ⓘ If it does not operate properly during operation test before use or use, stop using it.
- ⓘ Always check the transmitter and receiver battery voltage to ensure they have enough remaining capacity to complete the flight.
- ⓘ Confirm that the CGY760R is operating in the correct mode.

### ABOUT BATTERIES:

#### ⚠ WARNING

- ⓘ Newer high-end servos and other radio equipment are capable of

placing large demands on the power systems in use today. When using a regulator you must ensure that the regulator is capable of supplying the current demands of the equipment you have selected. In addition to this make sure the wiring and switch you have selected are capable of handling high current draws.

\*The servo current draw can be up to 50% higher on a flybarless helicopter. Always ensure your receiver battery is fully charged before each flight.

### **ABOUT CONNECTOR:**

❗ **Insert the connector such as sensor, servo, connection cord, battery etc., surely.**

\*If it is not securely inserted all the way in, it may come off due to vibration during flight and there is a danger of falling.

### **ABOUT WIRING:**

❗ **Please secure the wiring so that it does not rub against the helicopter frame or other such items that could cause wear. If it does so, we suggest covering these areas with fuel tubing (or similar) to prevent damage.**

### **ABOUT VIBRATION ISOLATION AND WATERPROOFING:**

❗ **The CGY760R is fixed with a dedicated mounting pad with good condition and the helicopter performs sufficient anti-vibration measures so as not to receive strong vibration at the time of flight. Also, if there is a risk of the gyro getting wet, place it in a plastic bag and take waterproof measures.**

### **ON FLIGHT PRECAUTION:**

❗ **Always exit programming mode before attempting to fly the model.**

*Gyro operating precautions:*

⊘ **The CGY760R requires 5-10 seconds to initialize when the power is turned on. Do not move the helicopter and do not move the tail rotor, aileron and elevator sticks during this initialization or the gyro may not initialize properly. Once the initialization process has been completed the swash servos and tail servo will move several times indicating that**

the CGY760R is now ready for flight.

❗ Verify that the gyros are operating and compensating in the correct direction before each flight. If the compensation direction is incorrect on any axis the model will become uncontrollable after takeoff.

❗ The servo type parameters within the CGY760R must match the type of servo you are using. Incorrect setting may damage the CGY760R or the servos, possibly resulting in a loss of control during flight.

❗ Always allow the gyro to adjust to the surrounding environmental temperature before flight. A large temperature change during use will cause drift and other operational issues.

❗ If you are switching between Normal Mode and AVCS Mode in flight, please keep in mind that you must have the gyro re-learn the center position after making a trim change within the transmitter. To memorize the new center position simply flip the gain switch on the transmitter three times between Normal Mode and AVCS Mode (Normal → AVCS → Normal → AVCS) within one second. The servo will center indicating that the new center position has been memorized.

❗ When operating the gyro in AVCS Mode, all compensation and revolution mixing must be disabled and any tail rotor or swash offsets for flight modes must be disabled.

❗ Do not drop the CGY760R onto a hard surface or subject the CGY760R sensor to a strong shock as this may damage the sensor.

❗ Verify that the gyro is operating in the desired mode.

❗ When the CGY760R is operated in AVCS mode the tail rotor or swash plate servos will not center when tail rotor, aileron or rudder stick is released. This is normal operation for AVCS mode. The servos may also move to the extent while the model is being carried out to the flight line. Before take off, you must visually center the tail rotor pitch slider and level the swash plate by using the transmitter control sticks. You can also center the servos by moving the tail rotor stick full left, then full right, back to full left and then allow the stick to center within

one second; the same method applies for aileron and elevator servos.

⊘ Never turn off the CGY760R while the GX (gyro) LED is blinking green at high speed (about 5 / sec).

\*If you turn off the power while high-speed blinking, setting changes can not be saved and data errors may occur.

### *Governor operating precautions:* **Governor**

❗ When the throttle servo is connected to the CGY760R, the battery failsafe function within the CGY760R must be setup and enabled.

❗ Throttle fail safe function (transmitter setting): Use the fail safe function for the channel that turns the governor on and off to set the fail safe position to the point at which the governor is turned off. With this setting, when the system enters the fail safe state, the governor will be turned off, and the receiver throttle signal (fail safe position preset) will be output directly.

❗ When using the condition hold function on the transmitter, always set the throttle servo maximum operating point to less than the point at which the governor is activated. If this is not done the governor may activate while in condition hold.

❗ While preparing for flight or starting the engine, always ensure the throttle remains below the governor activation point and do not select any flight modes that may activate the governor.

❗ If you prefer to activate the governor while the model is still on the ground, always ensure that you have at least -1 degrees of pitch in the model before activating the governor. This negative pitch is necessary to prevent an unexpected lift off as the governor activates and the head speed increases to the desired RPM.

❗ Be sure to set the autorotation condition to the OFF side with the governor ON / OFF switch function.

❗ Periodically check the RPM sensor output to ensure proper gover-

nor operation. Due to the high level of vibration and centrifugal forces the magnet may come loose or the sensor alignment may change. Every 10th flight verify that the magnet and sensor are properly mounted.

❗ If abnormality such as vibration etc., is recognized on the aircraft side during operation, be prepared to turn off the governor immediately.

## **MACHINE MAINTENANCE:**

### **⚠️WARNING**

❗ Even though the CGY760R is a high performance gyro and governor, it will be necessary to ensure that the helicopter mechanics are also in optimum operating condition. Please use the guidelines below and address all issues before installing and flying the CGY760R.

- The CGY760R must be used with a rigid tail rotor drive system. Any modern torque tube or belt drive system should be adequate. Do not attempt to fly the CGY760R using a wire driven tail rotor system.
- Always ensure the drive gears, torque tube, pulleys, belt, bearings and shafts are in proper working condition. If any of these items are damaged or worn they must be replaced.
- The linkage rod, tail rotor bell crank, pitch slider and tail rotor grips must operate without friction to obtain the best performance from the CGY760R. Binding in the tail rotor control linkage will decrease the performance of the CGY760R gyro and this may also shorten the servo lifespan. Please take the time now to ensure the tail rotor system on your helicopter is working correctly and without friction or binding.
- Vibration will affect the CGY760R's overall performance. All rotating components on the helicopter should be balanced to minimize vibrations in flight. Ensure that your engine or electric motor is running smoothly and that all vibrations have been addressed before installing and test flying the CGY760R.





## MOUNTING / PART NAMES / CONNECTING

Mount on a model using the attached mounting pad and mount it at the center position of model gyro mount so that it is exactly parallel to the roll and pitch axis of the aircraft.

\*The CGY760R should be mounted on a rigid platform, at least 6in [152mm] away from a Nitro Engine. It is not necessary to mount the gyro near the main shaft of the model but it is very important that the mounting area chosen is rigid. Please refer to your model manufacturer's instructions for recommended mounting locations.

\*Test fit the gyro sensor, ensuring that the sensor is in alignment with the model on the roll and pitch axis. The cable from the gyro sensor must exit toward the front or the rear of the model since this is the pitch axis. Any misalignment will cause a loss of performance.

### Mounting angle

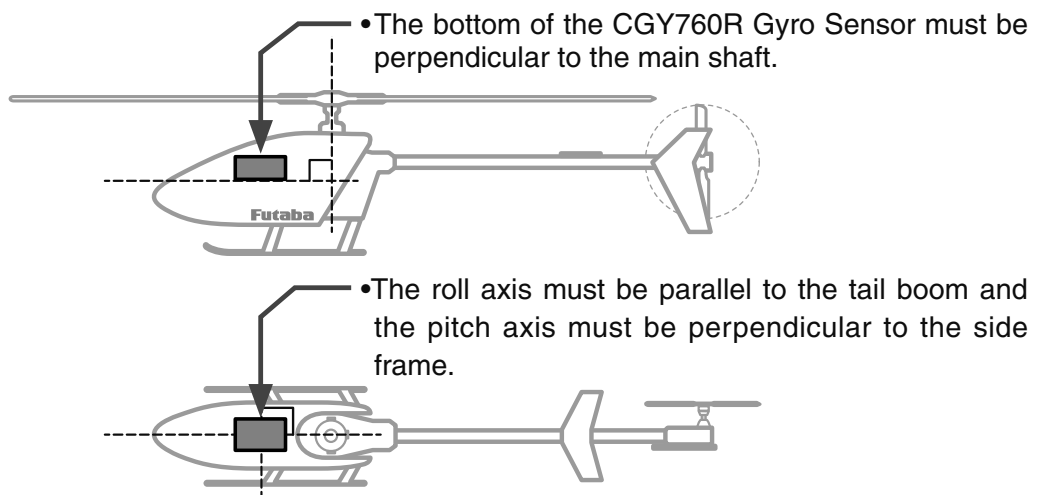

### Control axis

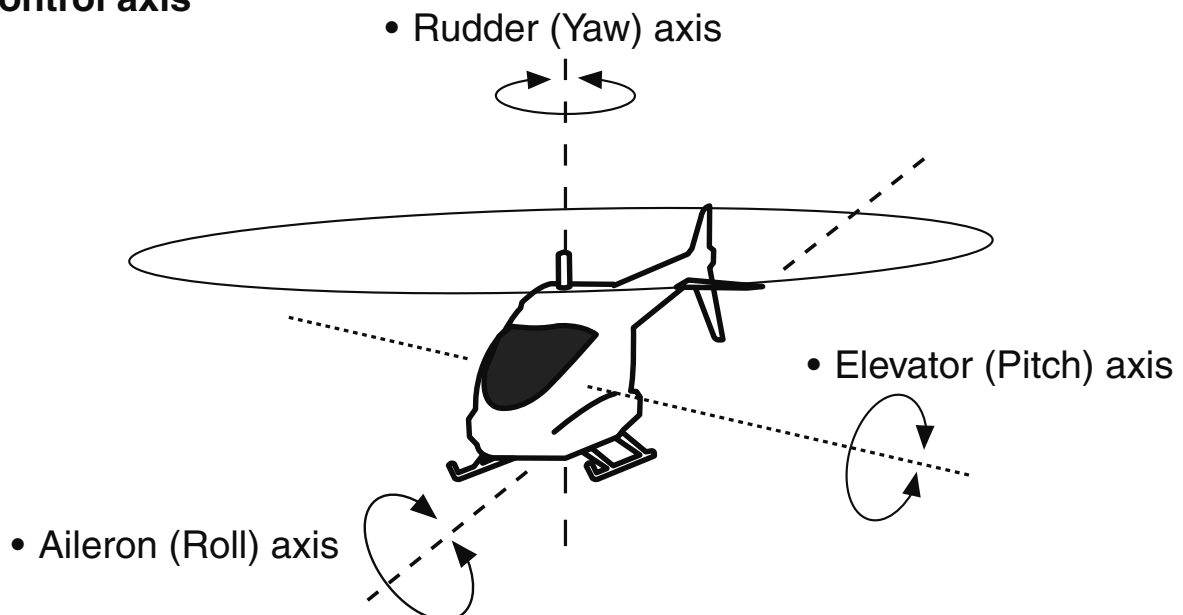

## Mounting The CGY760R

The CGY760R can be mounted in the orientation shown below unless it is installed so that the roll and pitch detection axis are aligned with the model. However, if there is a deviation of , equal to, or greater than 1/2 degrees, performance will degrade. In this step, please pay special attention to ensure optimum flight performance. Refer to the installation example below and select the gyro mounting direction with "Gyro Set Dir" (page 45) of the "SWH BASIC" menu.

\*The surface with the "CGY" mark in the figure is the top (LED) side of the CGY760R.

\*This is when the reverse function of each axis of the transmitter is initialized.

### Gyro Set Dir---1

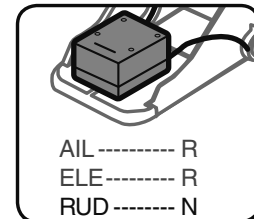
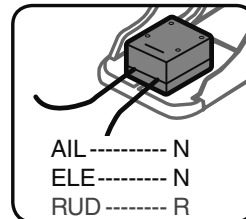
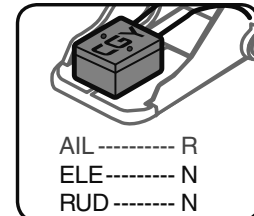
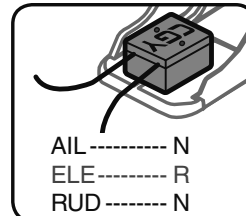
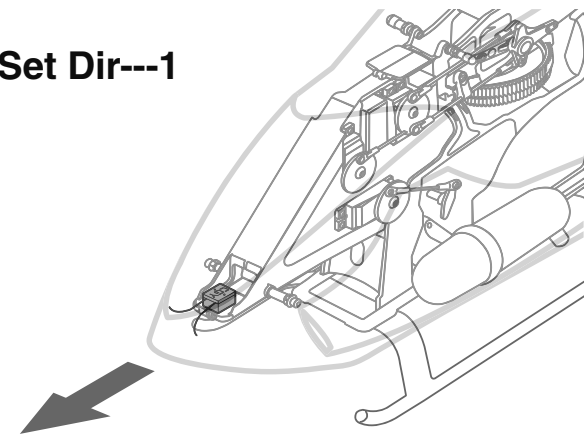

### Gyro Set Dir---2

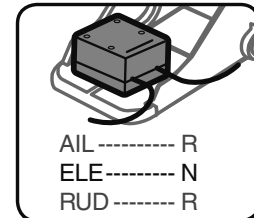
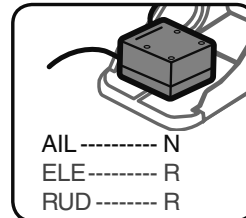
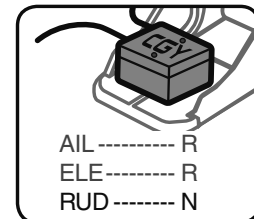
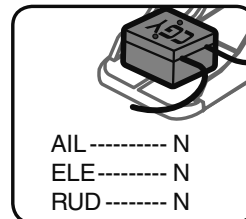
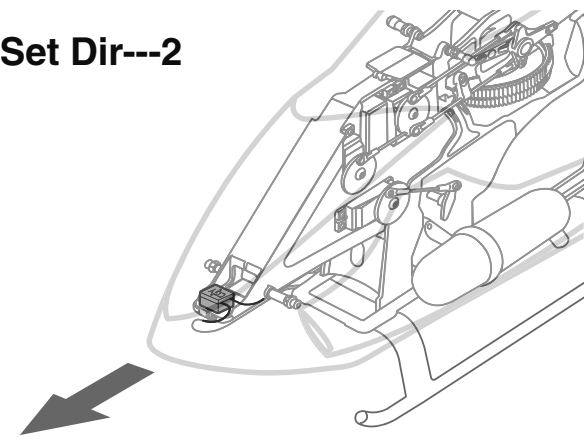

### Gyro Set Dir---3

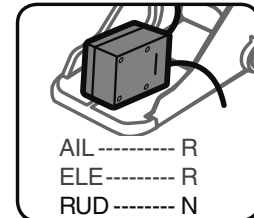
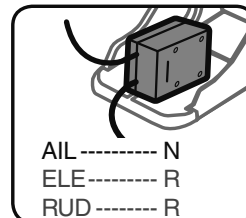
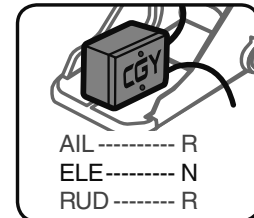
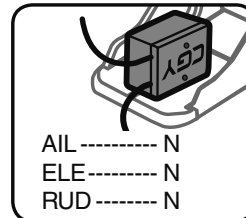
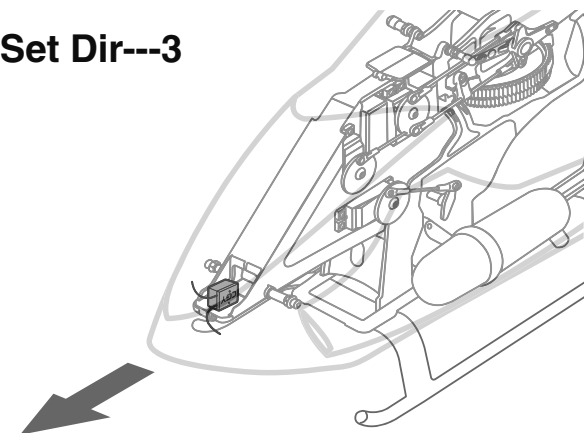

### Gyro Set Dir---4

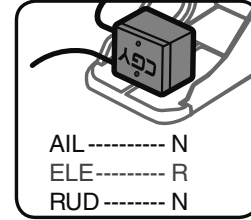
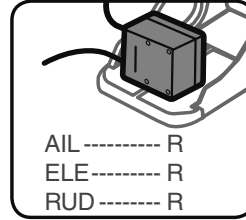
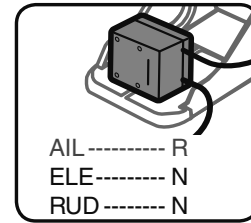
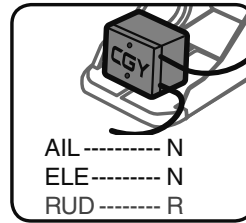
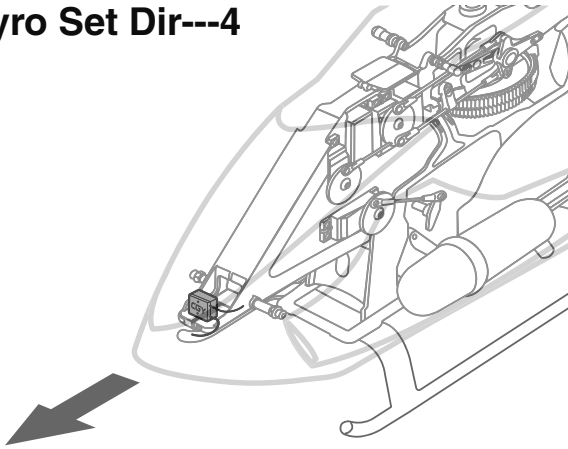

### Gyro Set Dir---5

\*Depending on the type of mounting plate, it is also possible to mount as shown in the figure.

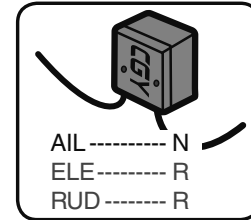
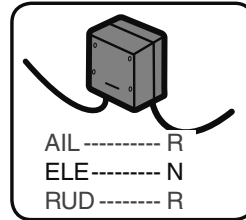
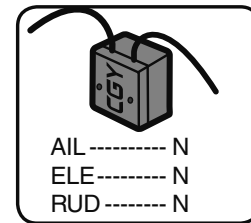
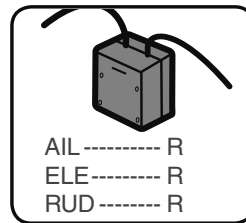
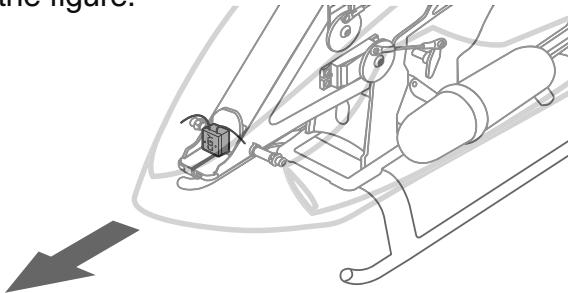

### Gyro Set Dir---6

\*Depending on the type of mounting plate, it is also possible to mount as shown in the figure.

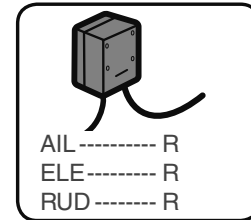
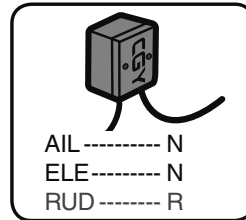
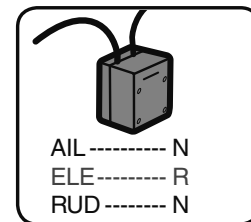
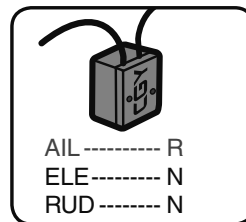
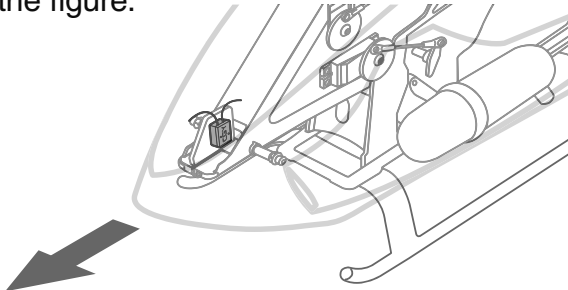

It is necessary to set the motion direction of each gyro by "AGy.Dir", "EGy.Dir" of "SWH. BASIC" menu (page 49) and "Gyro.Dir" of "RUD BASIC" menu (page 57).

AIL - Aileron (Roll) axis / ELE - Elevator (Pitch) axis / RUD - Rudder (Yaw) axis  
N --- Normal / R --- Reverse

\*Make sure that the cable connection to the main body is not too tight. The excess will account for some flexibility in the model without causing stress/wear on the cable. Roughly 1.5" of cable slack is preferable for best performance.

\*Please install the CGY760R as it is in the center (vertical direction and horizontal direction) of the tape without cutting the attached mount pad. This tape is designed to effectively absorb the vibration from the model.

\*Clean the oil on the bottom of the CGY760R and the machine mounting part with a solvent cleaner or the like.

\*The CGY760R is also designed to be screwed to the gyro mount. For suggested mounting methods, please refer to page 92 of this manual.

### ***The CGY760R Troubleshooting Tips***

If any issues are noted during flight (such as drifting, inconsistent hold or inconsistent control rates) then please review the following troubleshooting recommendations.

1. Always verify that the tail rotor and swash plate mechanisms operate, and that the drive system is in proper working order.
2. Electromagnetic interference could be causing the problem. If you feel everything is set up correctly and that the model is vibration free, then consider moving the gyro sensor to a new location away from servos, ESC, and drive motors.
3. Vibrations will decrease the performance of all gyro systems. Even though the CGY760R gyro sensor is the most vibration resistant gyro sensor available, eliminating vibrations will always improve performance. The CGY760R gyro sensor performs best when the sensor is mounted rigidly to the airframe. It is highly recommended to avoid using soft foam pads as this may allow the gyro to bounce around on the roll and pitch axis, causing instabilities and possible loss of control during flight so that the roll and pitch sensing axis are in alignment with the model. Any misalignments over 1/2 of a degree will cause a loss in performance. Please take extra care in this step to ensure the optimum flight performance.

### ***Using The CGY760R With An Electric Model***

#### **⚠ DANGER**

**❗ It is necessary to remove the pinion gear from the electric motor or disconnect the motor from the ESC before powering the model up for setup or bench testing. Electric motors are extremely powerful and capable of delivering the power instantly, causing injury to yourself, others, or the surroundings.**

Once the ESC is connected to the CGY760R, you need to complete all necessary transmitter settings (ATV / EPA / REV / ETC) according to ESC instructions. Please refer to page 70 of this manual for further suggestions on the use of the governor of CGY760R and the electric model.

### ***Link Method With Transmitter (FASSTest / T-FHSS)***

1. Connect the CGY760R and GPB-1 and set the same mode set in as the transmitter linking the CGY760R communication mode on the "Receiver" screen. (See page 36)
  2. Keep the transmitter and receiver close to each other and turn on the receiver with the transmitter in the link mode.
  3. After powering on the receiver, please allow for approximately two seconds for the binding/linking to occur.
  4. The LED indication on the receiver will change from the red blinking light to a solid green. This indicates that the linking is successful. This usually occurs in approximately one second.
- \* Refer to the transmitters instruction manual for complete details on how to place the transmitter into the linking mode.
  - \* If there are many T-FHSS or FASSTest systems in use when attempting to link the transmitter to the receiver, it might require more time to do so. Additionally, if another modeler in close proximity is attempting to link their units simultaneously, it could also cause difficulties as the receiver might inadvertently link to the other transmitter. Always confirm that the receiver responds to the input from the desired transmitter.
  - \* If the System Type of the transmitter is changed, the receiver will need to be re-linked to the transmitter. For example, if the transmitter is changed from T-FHSS to FASSTest, it will be necessary to perform the linking procedure once again.

#### **⚠ WARNING**

- ⊘ **Do not perform the linking procedure while the motor's main wire connected or the engine is operating as it may result in serious injury.**
- ⓘ **When the linking is complete, please cycle the receiver power and ensure the receiver is properly linked to the transmitter.**
- ⓘ **Please power up your system in this order. Transmitter first, followed by the receiver.**
- ⓘ **If the CGY760R was previously linked to another transmitter, make sure that transmitter is not operating while linking the receiver to the new transmitter.**

## Connecting The CGY760R

### GX (Gyro) LED

LED	State
<b>Solid red</b>	Normal operation.
<b>Blinking green</b>	Normal blinking (about 2 / sec): S.BUS data wait time. High-speed blinking (about 5 / sec): Backing up data. ⊙ Never shut down during backup.
<b>Blinking red</b>	Indicates an error has occurred. For example, the gyro is not functioning correctly. If normal operation does not return after cycling the power off/on once again and/or replacing the battery, please contact our customer service department.



### RX (Receiver) LED

LED	State
<b>Solid green</b>	Normal operation.
<b>Solid red</b>	No signal reception
<b>Red and Green turn on alternately</b>	Unrecoverable failure (EEPROM, etc.) Cycle the power off/on once again to return to normal operation. If this is not successful, please contact our customer service center.

### (9) P.BOX:

- Connect to CGY760R when making settings. When setting is completed remove it.



### LCD

- Displays menus, parameters.

### Edit key

- Used to set operating parameters.

### (10) Transmitter Connection Cable:

- Connect when using the transmitter to wirelessly transfer settings of GPB-1 to CGY760R.

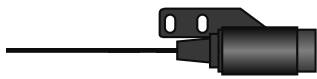

**(1) RPM (Revolution sensor):**

- Connect the revolution sensor.

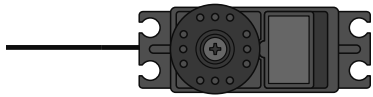

**(2) AIL Output:**

- Connect the aileron (roll) servo.

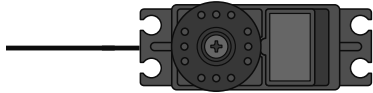

**(3) ELE Output:**

- Connect the elevator (pitch) servo.

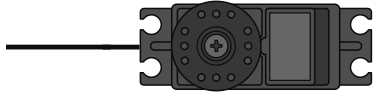

**(4) PIT Output:**

- Connect the pitch (collective pitch) servo.

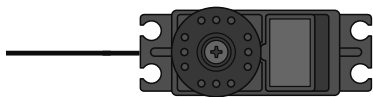

**(5) THR Output:**

- Connect the throttle servo.
- Connect the ESC w/BEC and set the operation mode to Gyro+THR mode.

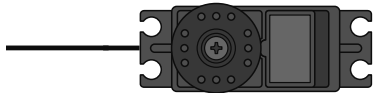

**(6) RUD Output:**

- Connect the rudder (yaw) servo.

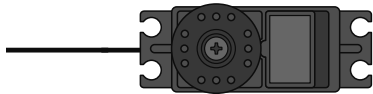

**(7) ELE2 Output:**

- Connect the second elevator servo.  
(Swash mode: H4-XX)



**(8) S.B2 Output:**

- Connect the S.BUS2 tool.

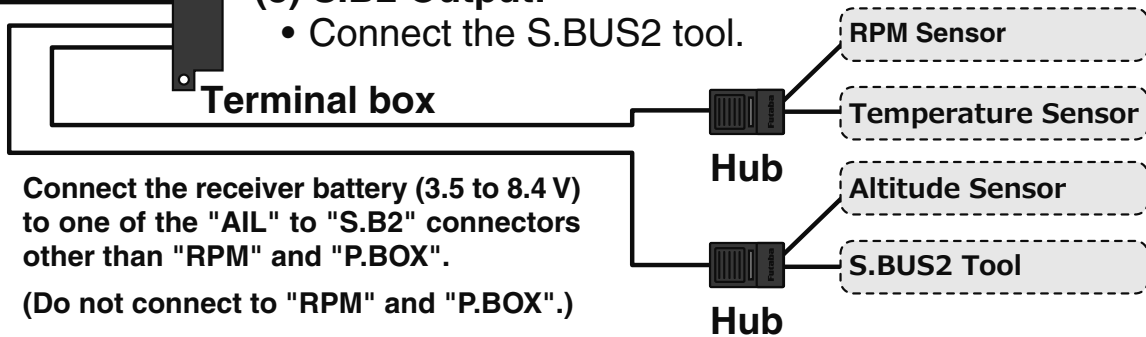

Connect the receiver battery (3.5 to 8.4 V) to one of the "AIL" to "S.B2" connectors other than "RPM" and "P.BOX".  
(Do not connect to "RPM" and "P.BOX".)

\*This diagram shows the various connections between the CGY760R and receiver, servo, or sensors.

\*S.BUS2 is a system that supports bidirectional communication from a telemetry sensor to a receiver by extending the conventional S.BUS. Telemetry sensor(s), etc., are connected to S.BUS2 connector and used. S.BUS compatible servo(s), etc., can not be used with S.BUS 2 connector terminal.

## ***S.BUS Channel Setting***

The default CGY760R S.BUS channel assignments should work properly with most Futaba transmitters. If you experience any problems please refer to the S.BUS section of the manual to set / verify each channel number for each function.

1. The "SBUS BASIC" menu (page 40 as of this draft.) of CGY760R is displayed.
2. Use the [▲/+ ] or [▼/- ] key to select "AIL CH #" and press the [Enter] key to enter setting mode. Check the transmitter's aileron channel and set it to match the channel with the [▲ /+ ] or [▼/- ] key. When you are done, press [Enter] key to exit setting mode.
3. Perform the same operation as above and set the function (such as aileron, pitch, collective, tail rotor gain, rotor head gain, RPM, gv on/off) channels to the transmitter.
4. If your transmitter does not offer enough channels to operate all of the CGY760R's functions, it is possible to operate the CGY760R without the Gov SW, Rotor Head Gain channels connected. When any of these functions are not used, it is necessary to set the channel number to "INH" within the CGY760R's S.BUS menu. Doing so disables the function and enables the user of the value set in the CGY760R menu accordingly.

When the Gov SW channel is not used, the governor on/off control is handled by the [Stick Switch] function.

## ***Governor Installation***

To install the governor, it will be necessary to modify the helicopter's cooling fan. Installation of the sensor and magnet are shown below. Balance the cooling fan as needed following magnet installation.

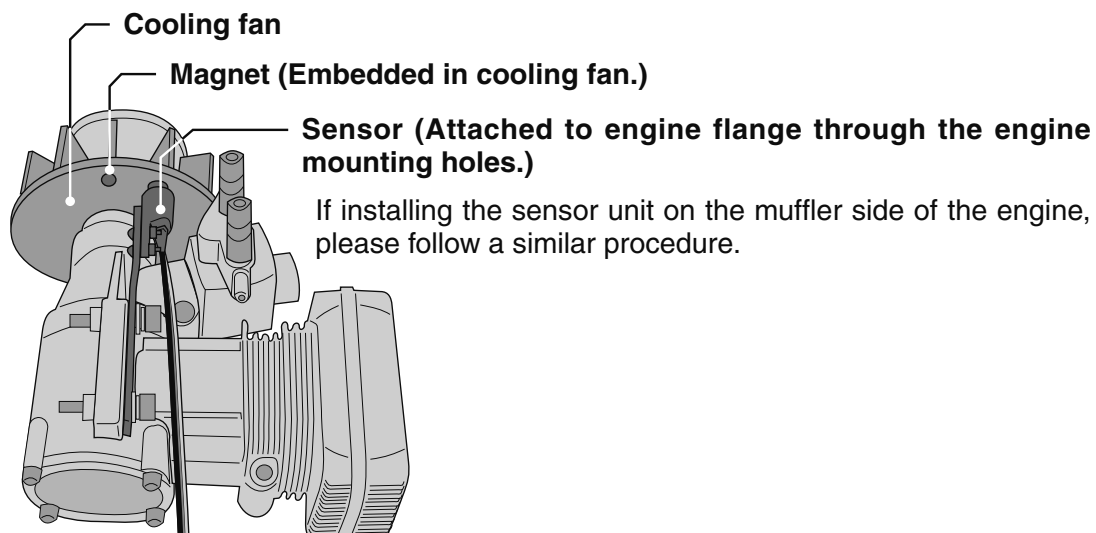



### ❑ *Magnet Operating Side Check*

Bring the magnet near the end of the sensor and check the operating side.

\*This is the side at which the displayed value increases in the "Revolution sensor testing" menu within the "Governor Basic Setting" section earlier in this manual. Install the magnet with this side facing the sensor. Mark this side of the magnet with a felt tip pen.

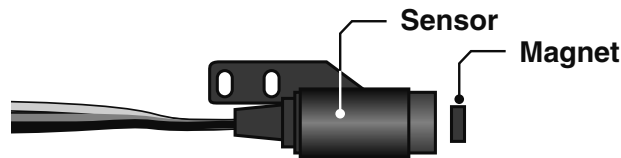

### ❑ *Cooling Fan Modification*

1. Drill a hole in the fan at the magnet mounting position. Make the hole about 4.1mm in diameter and 1.5 to 1.7mm deep.
2. Embed the magnet in this hole in the direction in which an output is obtained. Use epoxy adhesive that cures in 30 minutes or longer. Do not use epoxies that contain metal such as JB Weld.

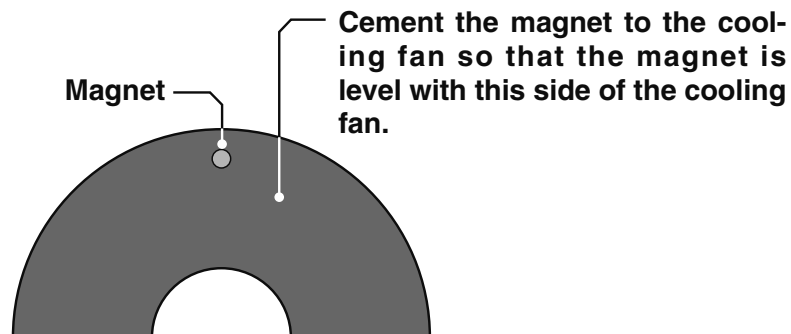

3. If the cooling fan is unbalanced and vibrates, etc., balance it by mounting the spare magnet to the opposite side of the cooling fan in the opposite polarity (so that it does not output a signal).

### ❑ *Sensor Mounting*

The sensor mounting method depends on the model and engine.

1. Temporary the sensor to the sensor mount.
2. Drill a hole in the fan cover at the part corresponding to the sensor so that the distance between the sensor and magnet can be made 1 to 2mm.

3. Tighten the sensor stay together with the engine mounting flange. (Temporary assembly)
4. Select the mounting method so that the sensor does not touch the frame, or other parts of the model. Temporarily mount the sensor and select the magnet mounting position.
5. Install the sensor to the sensor stay using the accessory screws and washers.
6. Tighten the sensor stay together with the engine using the engine mount screw.

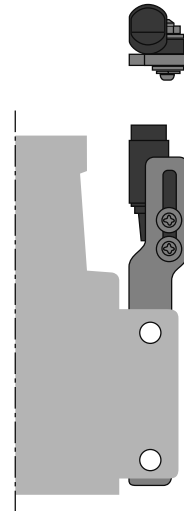

### ☐ *Sensor Adjustment*

1. Adjust the sensor position to obtain a sensor output of at least 60% in the "Revolution sensor testing" menu within the "Governor Basic Setting" .

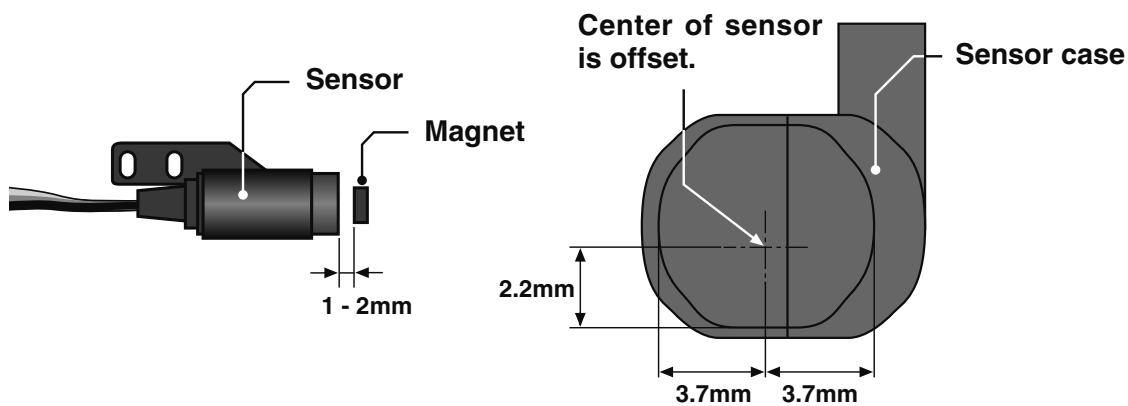

2. The center of the sensor is different from the center of the sensor case so be careful when mounting the sensor.  
If the display is less than 60% when the magnet is directly below the sensor, bring the sensor closer to the magnet so that the 60% or more is displayed. The magnet and sensor gap criteria is approximately 1 to 2mm. If a sensor output is not obtained even when the sensor is brought close to the magnet, the magnet and sensor center positions may have changed.
3. Complete assembly of the sensor by securely tightening the screws that were temporarily tightened.
4. Recheck the sensor output.

### **☐ *Throttle Servo Linkage Precautions***

- To effectively use the governor, observe the following precautions when connecting the servo linkage.
- Make the servo operating range as wide as possible. Make the throw of the transmitter EPA (ATV) function and AFR function as close as possible to 100%.
- Fly with the governor turned OFF and adjust the needle so that the engine smoothly reacts to movement of the transmitter stick.
- If there is a point at which the reaction of the engine is considerably different due to a too rich or too lean mixture, the governor may not operate to its maximum potential.

### **☐ *Fuselage Vibration Countermeasures***

If the model frame is weak, or the engine mount is deformed or not installed properly, the vibrations applied by the engine will increase. Engine vibrations will lead to unstable speed and prevent the governor from providing maximum performance. Therefore, make sure that the engine is vibration free and that the carburetor provides linear throttle control because the governor can not correct engine problems.

### **☐ *Use Of A Tuned Silencer***

The use of a tuned pipe type silencer may cause the engine throttle response to be substantially different from that of a normal muffler. Adjust the needle (and pipe length) so that engine speed changes are proportional to the throttle opening. The governor will not perform satisfactorily with a muffler or a pipe that does not allow the carburetion to be linear.

**Connect GPB-1 (Gyro Program Box) And CGY760R**

The GPB-1 is used to display the gyro and governor settings, adjust the gyro and governor settings, and use to initialize updates, etc.

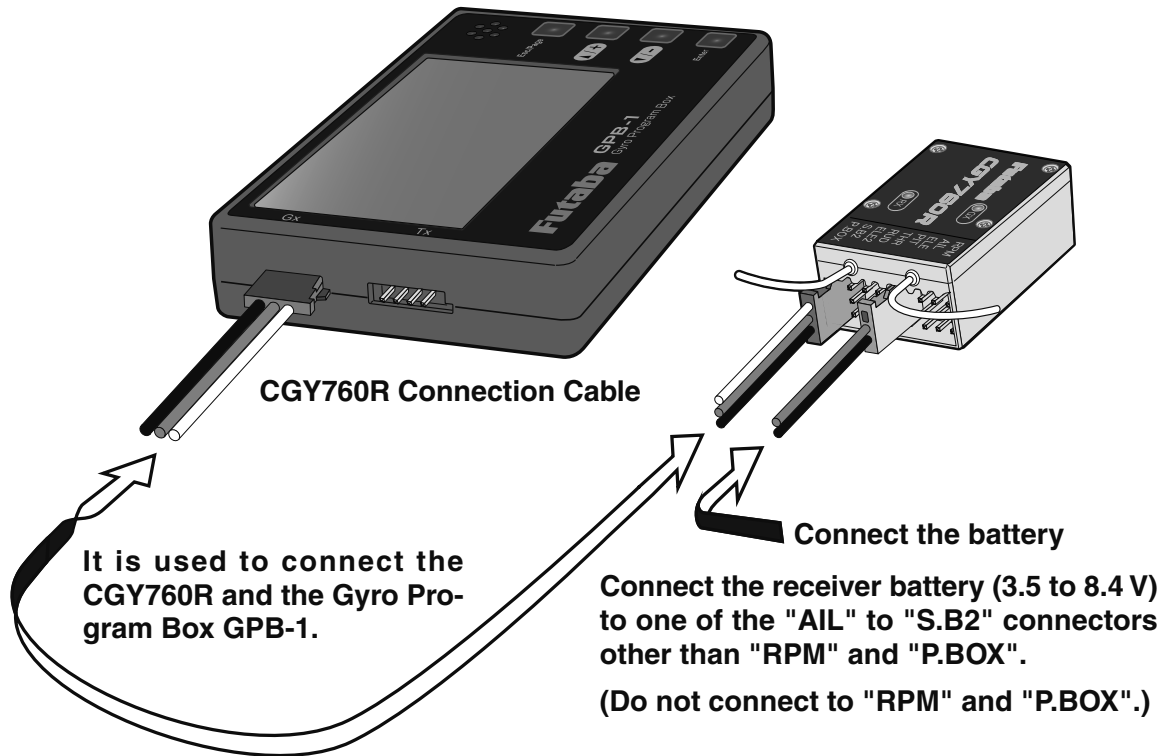

**⚠ CAUTION**  
 ⚠ Be sure to connect and disconnect the CGY760R and GPB-1 connection cord with the power off.

**Opening Screen And Home Screen**

When GPB-1 starts up with power on, the opening screen is displayed first, then the home screen is displayed.

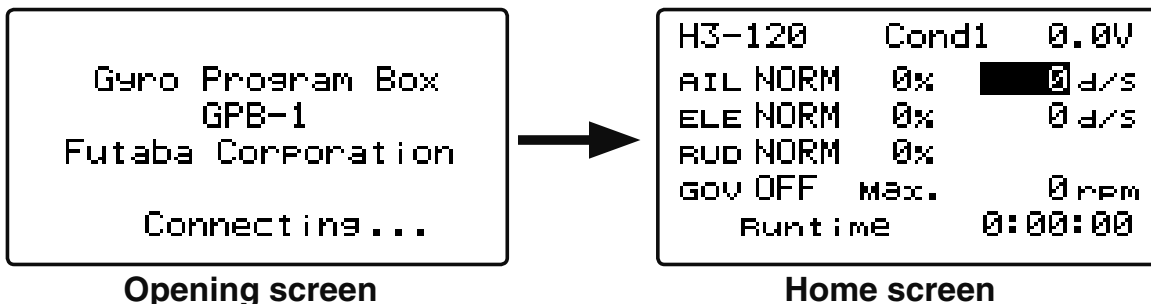

Each menu screen is displayed from the home screen.

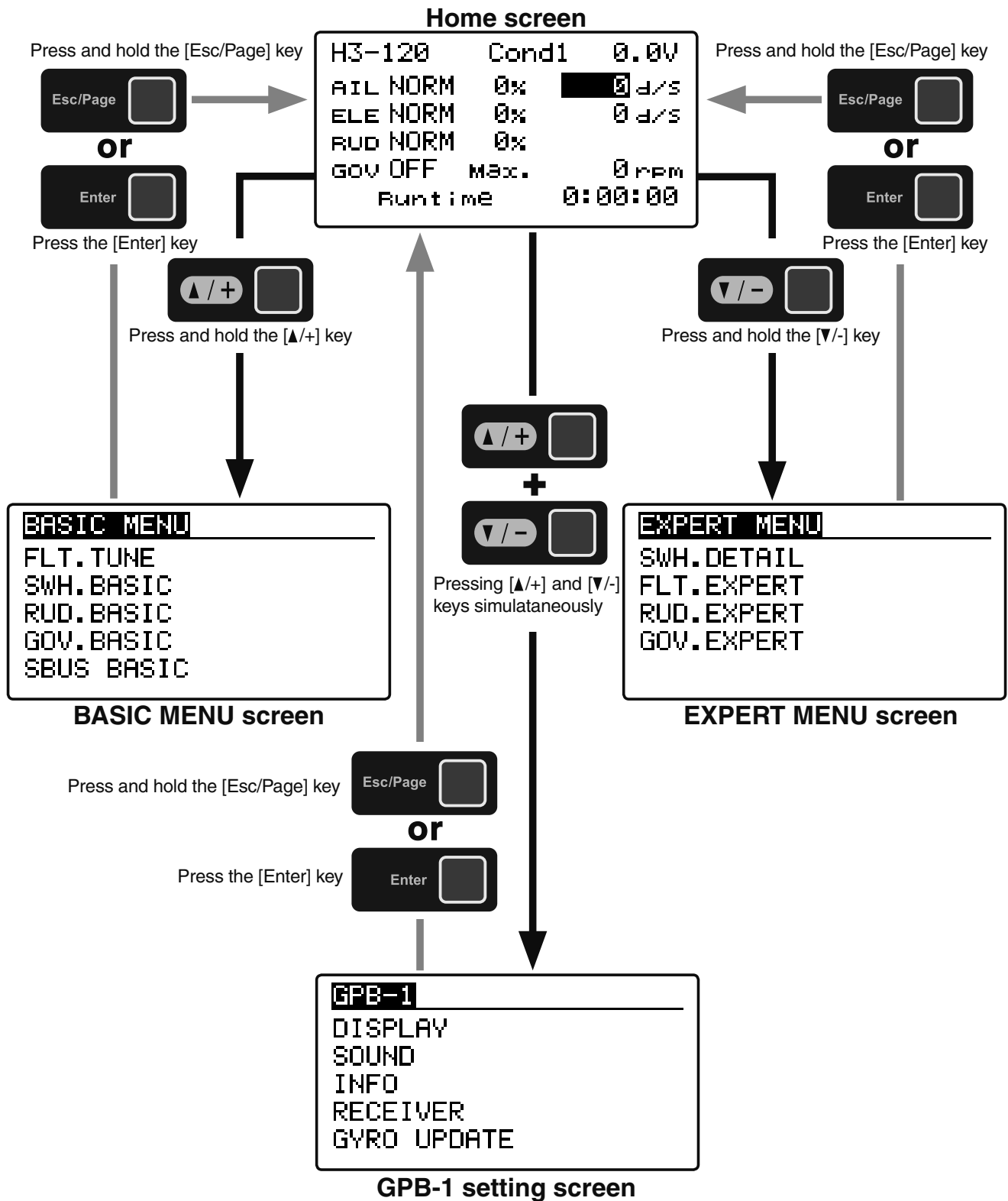

# HOME SCREEN

## Home Screen Display

On the home screen, basic information such as swash type, gyro operation mode, sensitivity and governor ON / OFF, engine operating time etc, are displayed.

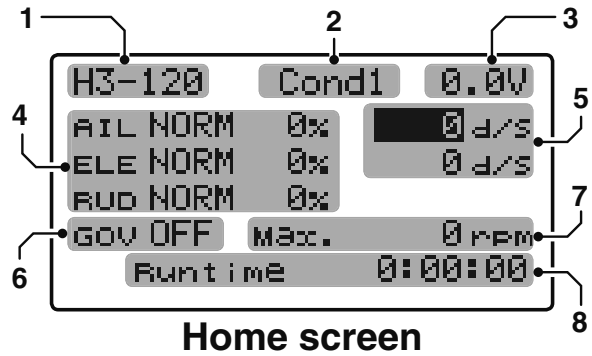

### 1. Swash plate type

Displays the swash plate type set in "SWH. BASIC" menu.

### 2. Condition number

With switch operation from the transmitter, several parameters can be switched by setting up to 5 types of data. If you set the condition switch to the channel having the AFR function of the transmitter and set the point for each flight condition with the AFR point curve, it can also be linked with the flight condition switch.

•When either the DG1 or DG 2 switch is selected, the following options are available.

Function Menu of your transmitter (DG1). Assigning DG1 to a switch or flight mode allows the use of two separate values for the condition selectable parameters.

For functions that can set conditions in this manual, mark **Cond** is written.

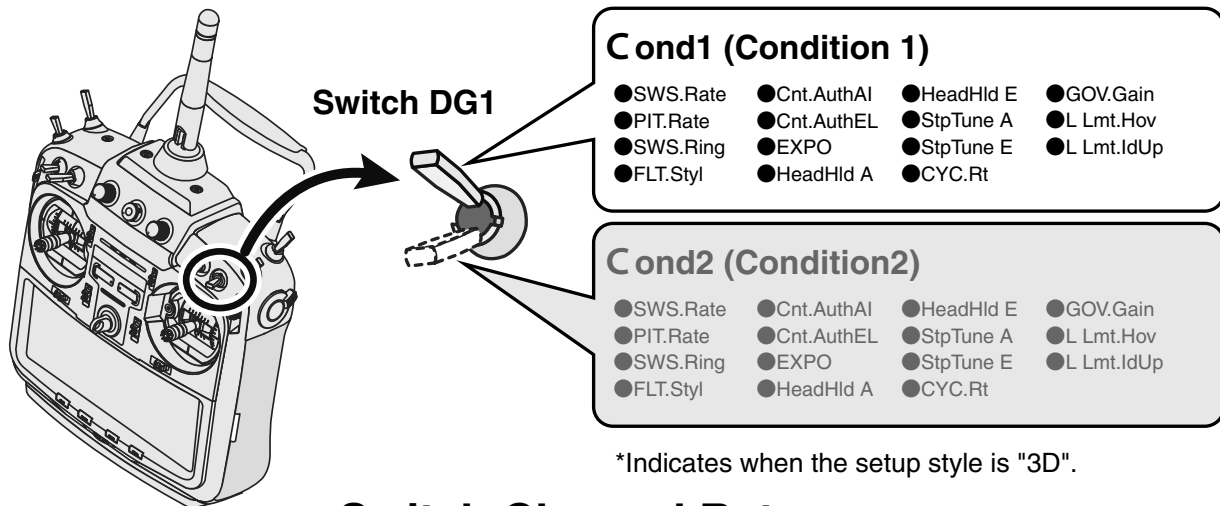

## Switch Channel Rate

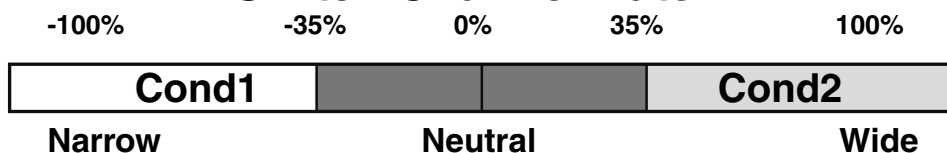

•If you set a condition switch channel, using the AFR function on that channel set a flat point curve for each flight condition. Then you can utilize all 5 flights conditions.

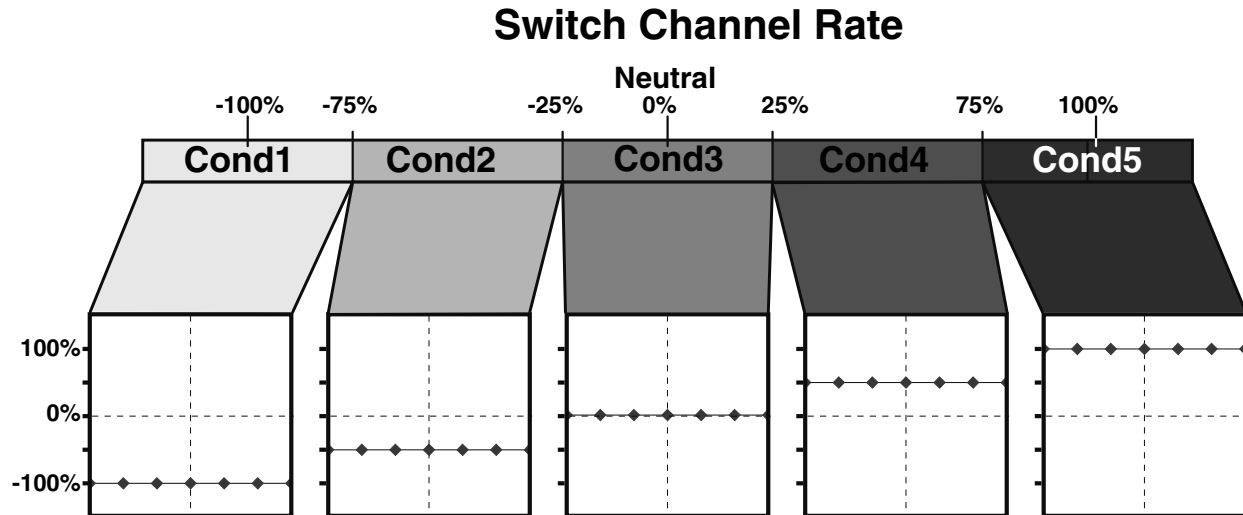

Set the point curve with AFR for each flight condition of the transmitter.

### 3. *Battery voltage*

Displays the voltage of the receiver battery connected to CGY760R.

### 4. *Gyro operation mode / Gyro gain*

Displays "AVCS" or "Normal" operation mode and gyro gain of aileron (roll), elevator (pitch) and rudder (yaw) axis.

### 5. *Roll and Elevator rate maximum display*

This screen displays the maximum roll rate and maximum elevator rate recorded during flight. Data is reset when the power is turned off. If you want to check the maximum rate, leave the power on after flight. Use the [▲/+ ] or [▼/- ] key to move the cursor to each rate display and press and hold [Enter] key to reset the display.

### 6. *Governor ON / OFF*

Indicates the ON / OFF switch status of the governor function. When "ON" is displayed, the governor function is activated.

## ***7. RPM display***

The maximum RPM of the engine or rotor head RPM memorized by the governor during operation is displayed. Data is reset when the power is turned off. If you want to check multiple times during the flight, leave the power on after flight. Use the [▲/+] or [▼/-] key to move the cursor to the engine RPM display and press and hold [Enter] key to reset the display.

## ***8. Engine running time***

Displays the running time of the engine. Up to 9,999 hours are displayed.

Use the [▲/+] or [▼/-] key to move the cursor to the operation time display and press and hold [Enter] key to reset the display. The operation time is stored in memory even when the power is turned off until it is reset.

## ***Data saving screen***

After setting change the following screen will be displayed when saving data.

(Note that this is only displayed a short period of time.)

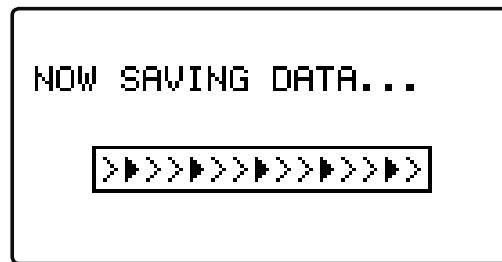

## ***How to operate each menu screen***

Use the [▲/+] or [▼/-] key to move the cursor to the setting item on the screen and press the [Enter] key to enter the setting mode. [▲/+] or [▼/-] key to change the setting contents. When you are done, press [Enter] key to exit setting mode.

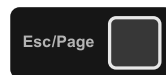



# GPB-1 Screen

This is the menu option for setting the GPB-1 display, etc.

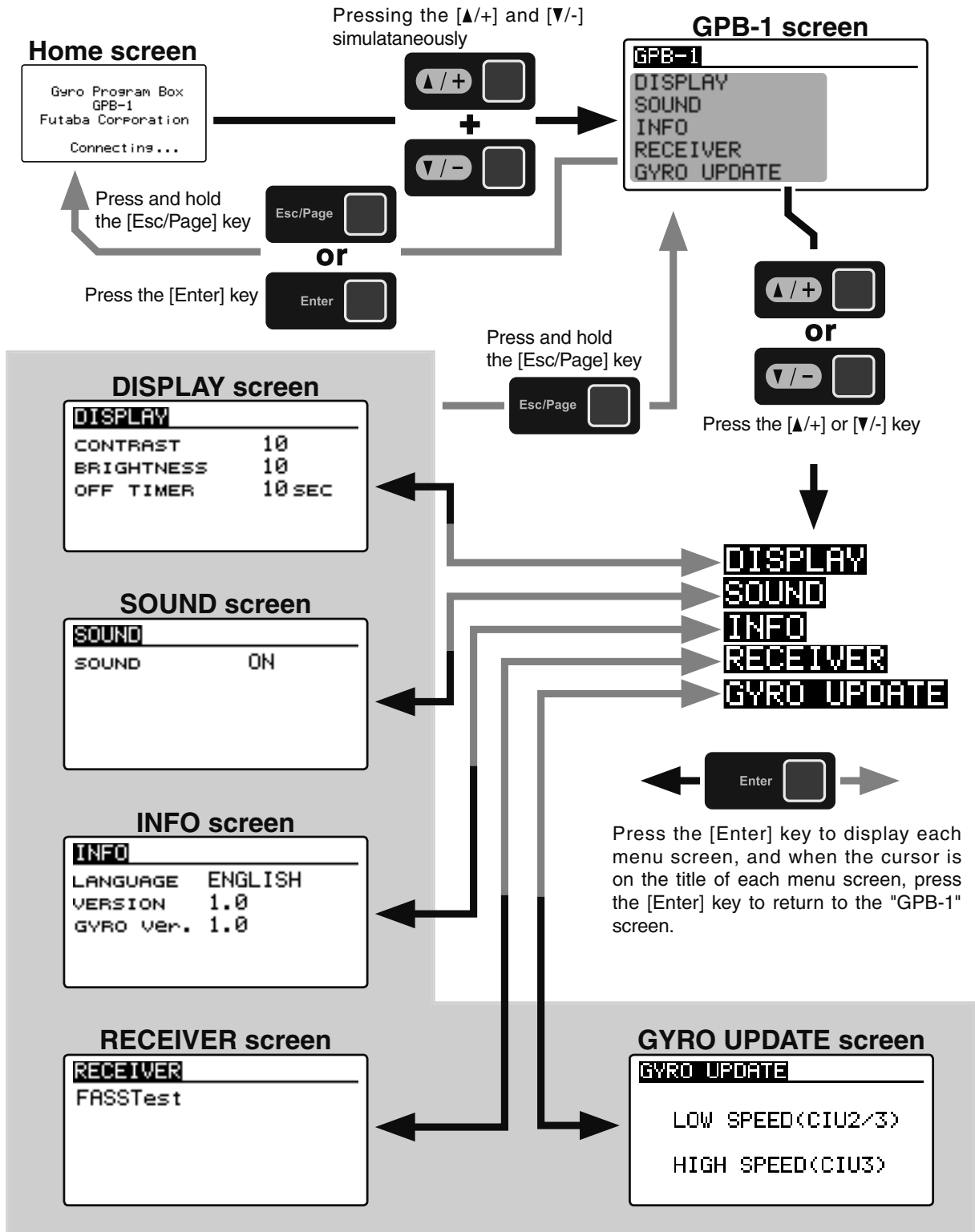

## DISPLAY (display setting of GPB-1)

Set the contrast and brightness of the screen of the GPB-1 and the lighting time of the backlight. Refer to page 33 to display the "DISPLAY" screen from the GPB-1 menu screen.

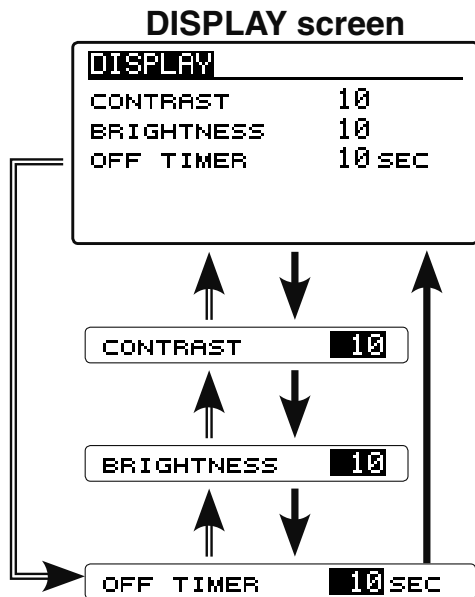

### (1) CONTRAST **CONTRAST 10**

Move the cursor to "CONTRAST" with the [▲/+] or [▼/-] key and press the [Enter] key to enter the setting mode. Adjust the contrast with the [▲/+] and [▼/-] keys. When you finish adjusting, press [Enter] key to exit setting mode.

Setting ranges: 0 ~ 20 Initial value: 10

### (1) BRIGHTNESS **BRIGHTNESS 10**

Move the cursor to "BRIGHTNESS" with the [▲/+] or [▼/-] key and press the [Enter] key to enter the setting mode. Adjust the brightness with the [▲/+] and [▼/-] keys. When you finish adjusting, press [Enter] key to exit setting mode.

Setting ranges: OFF (Backlight off) / 0 ~ 20 Initial value: 10

### (1) OFF TIMER **OFF TIMER 10 SEC**

Adjust the time until the backlight turns off after the last key operation.

Move the cursor to "OFF TIMER" with the [▲/+] or [▼/-] key and press the [Enter] key to enter the setting mode. Use the [▲/+] and [▼/-] keys to adjust the lighting time of the backlight.

When you finish adjusting, press [Enter] key to exit setting mode.

Setting ranges: OFF (Always on) / 0 ~ 240 sec Initial value: 10 sec

## ***SOUND (Key beep sound of GPB-1)***

This menu is used to turn on, or off, the sounds when the keys of the GPB-1 are utilized. Refer to page 33 to display the "SOUND" screen from the GPB-1 menu screen.

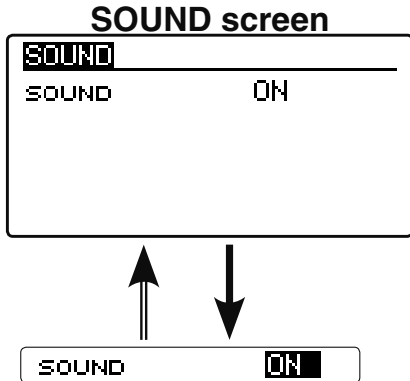

### **(1) SOUND** SOUND ON

Set ON / OFF of key operation sound of GPB-1.

Move the cursor to "SOUND" with the [▲/+ ] or [▼/- ] key and press the [Enter] key to enter the setting mode. Select the ON or OFF of key operation sound with the [▲/+ ] or [▼/- ] key. When you finish setting, press [Enter] key to exit setting mode.

**Setting: ON / OFF Initial setting: ON**

## ***INFO (Display language and version of GPB-1)***

Displays the GPB-1 display language setting, program version and gyro version. Refer to page 33 and display the information screen from the GPB-1 menu screen.

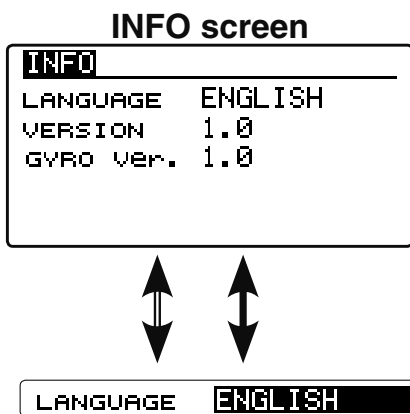

### **(1) LANGUAGE** LANGUAGE ENGLISH

Set the display language of GPB-1.

Move the cursor to "LANGUAGE" with the [▲/+ ] or [▼/- ] key and press the [Enter] key to enter the setting mode. Select the display language with the [▲/+ ] or [▼/- ] key. When you finish setting, press [Enter] key to exit setting mode.

**Setting: ENGLISH / JAPANESE / GERMAN**

## RECEIVER (Receiver system setting)

On the "RECEIVER" screen, make sure that the CGY760R setting matches the protocol that is selected/utilized in the transmitter. For example, if the transmitter is set to FASSTest, the CGY760R screen should also reflect the FASSTest option. Refer to page 33 and display the "RECEIVER" screen from the GPB-1 menu screen.

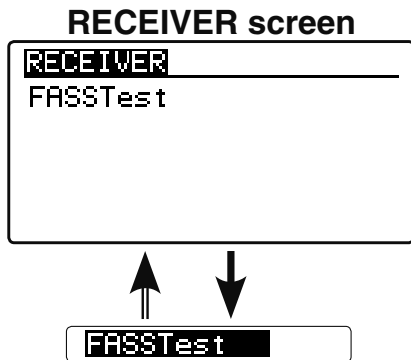

### (1) RECEIVER FASSTest

Set the same system as the transmitter to be linked. Move the cursor to the system such as "FASSTest" with the [▲/+] or [▼/-] key and press the [Enter] key to enter the setting mode. Then select the system with the [▲/+] or [▼/-] key. Since "EXECUTE: Enter (1sec)" is displayed. Pressing the [Enter] key for about 1 second changes the selected system and exits the setting mode.

Setting: FASSTest- / T-FHSS

#### Note:

To change the "Receiver System" type, first power off the transmitter and receiver, and re-power the CGY760R while the transmitter is still in the OFF position. The only way to change the receiver type is by power cycling the gyro first.

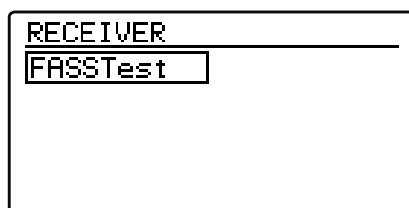

FASSTest

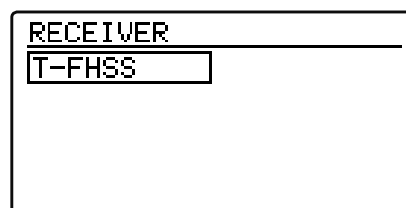

T-FHSS

## ***GYRO UPDATE (Update mode of CGY760R)***

This menu is used to adjust the update mode of the CGY760R. The mode selected will be determined by the model of the CIU selected and personal preference. For example, when using the CIU-3, the user may select either the high speed or the slow speed modes. If using the CIU-2, only the slow speed mode is available.

- \* The following optional products are required for the update.
- CIU-2 or CIU-3
- Cord for CGY760R / GY701 / GY520 or DSC cord for update

### ***(1) Download CGY760R update file***

Download the CGY760R update file from our website or your local distributor's website.

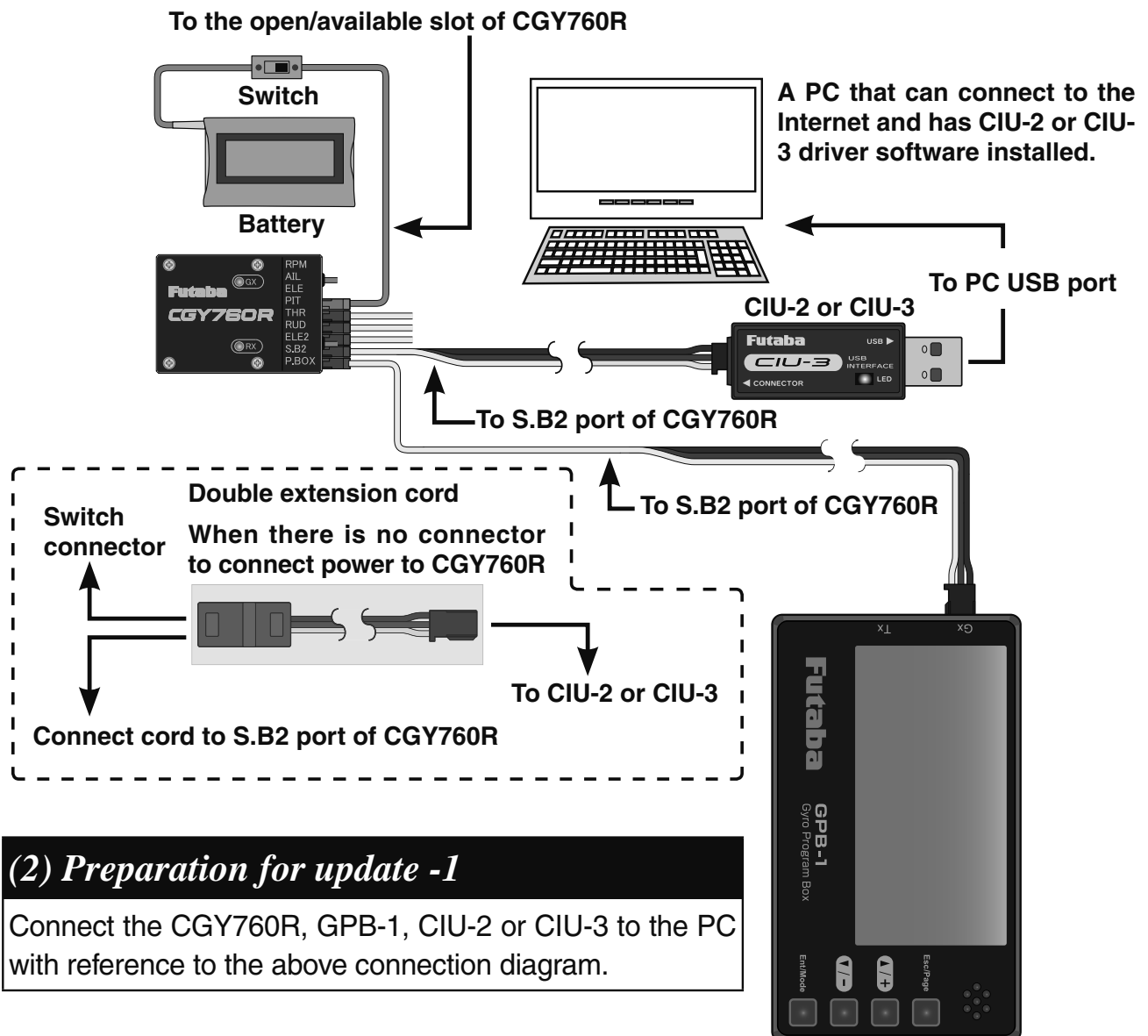

### ***(2) Preparation for update -1***

Connect the CGY760R, GPB-1, CIU-2 or CIU-3 to the PC with reference to the above connection diagram.

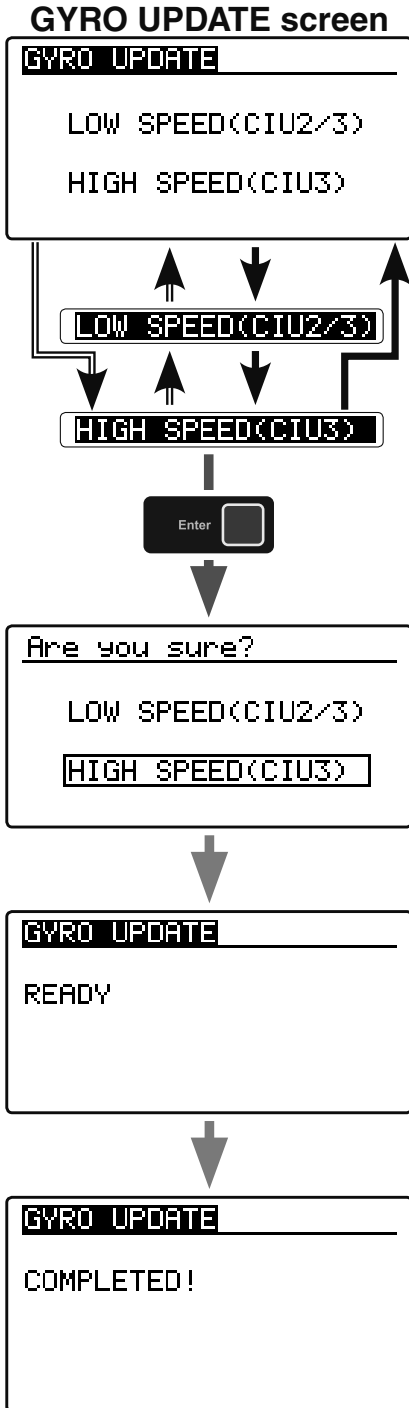

### **(3) Preparation for update -2**

Refer to page 33 and display the "GYRO UPDATE" screen from the GPB-1 menu screen.

### **(4) Selection of CIU (Speed)**

LOW SPEED(CIU2/3)  
HIGH SPEED(CIU3)

Use the [▲/+] or [▼/-] key to move the cursor to "LOW SPEED (CIU2/3)" or "HIGH SPEED CIU3" and press the [Enter] key. The "READY" indication will appear on-screen when the update is available.

### **(5) Perform update**

Click on the update file downloaded to the PC to update the CGY760R.

### **(6) Update complete**

When the update has been successfully concluded, "Completed" appears on the screen of GPB -1.

If the update is not performed normally, "FAILED !" will be displayed. In If the update has failed, please start the process once again from the beginning. Should it fail once more, it is likely that the update file has been corrupted when downloaded previously. Please download this file and restart the procedure.

GYRO UPDATE  
FAILED !

# BASIC MENU

As the name suggests, this menu allows changes to the basic settings of CGY760R. Make sure to set each "BASIC MENU".

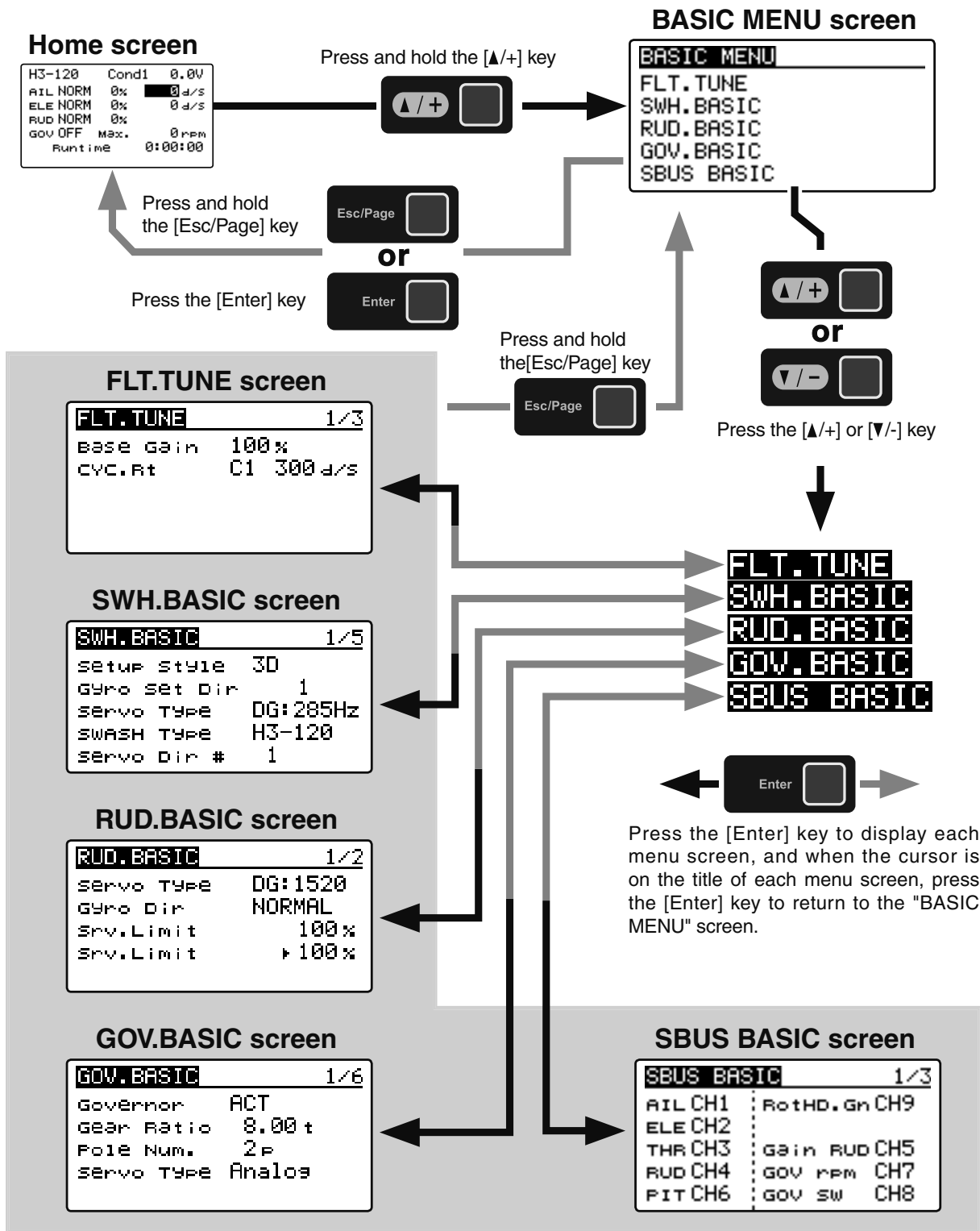

# SBUS BASIC MENU (S.BUS BASIC SETTING)

The "SBUS BASIC" screen is accessed via the "BASIC MENU" screen (see page 39). Set the CH for each function according to the transmitter to be used. Any unused functions should be set to INH (Inhibited). For example, if the Gain A/E and Gain RUD remote gain functions are not going to be used, then set them to [INH]. The CGY760R will then allow you to make gain adjustments within the respective menu.

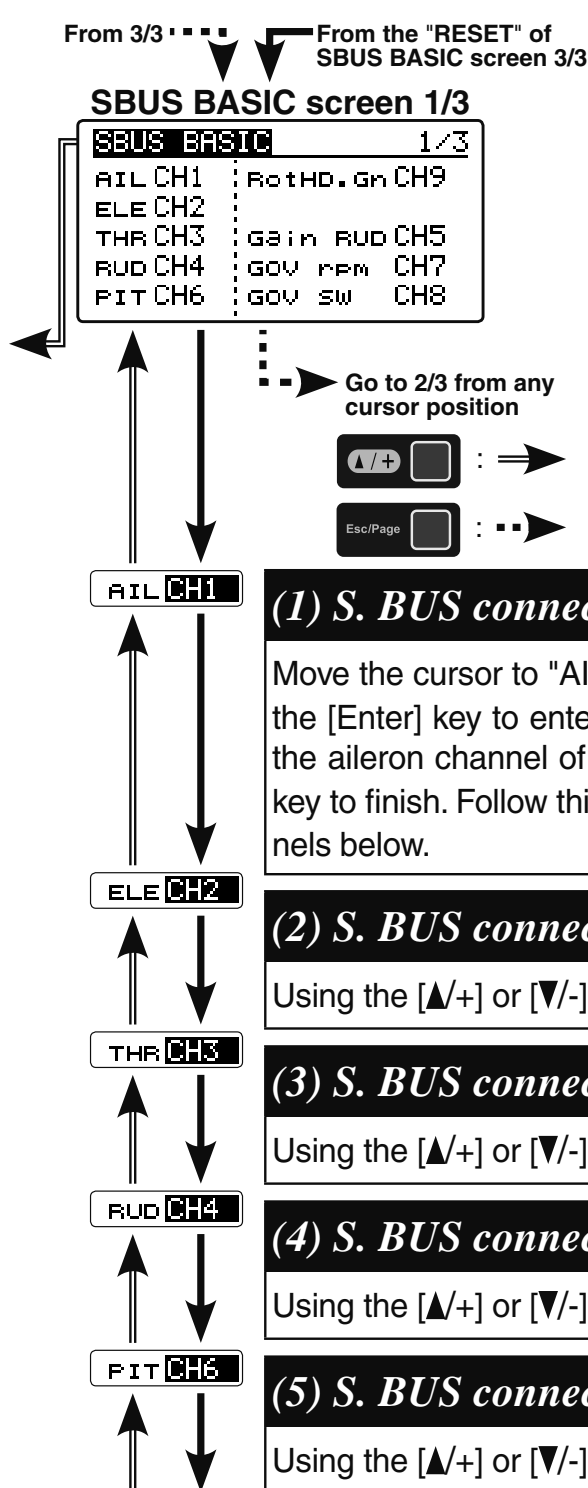

## **⚠ WARNING**

**!** Always verify that the S.BUS function assignments match your transmitter's function (in the FUNCTION menu) assignments. If any changes are made within the transmitter function assignments, then it will also be necessary to make the changes within the S.BUS function assignments. Change the setting with the transmitter turned off.

### **(1) S. BUS connection: AIL (Aileron) channel** AIL CH1

Move the cursor to "AIL CH #" by pressing the [▲/+] or [▼/-] key and press the [Enter] key to enter the setting mode. Use the [▲/+] or [▼/-] key to set the aileron channel of the transmitter. When you are done, press [Enter] key to finish. Follow this procedure to make the adjustments to all channels below.

### **(2) S. BUS connection: ELE (Elevator) channel** ELE CH2

Using the [▲/+] or [▼/-] key to set the correct channel number.

### **(3) S. BUS connection: THR (Throttle) channel** THR CH3

Using the [▲/+] or [▼/-] key to set the correct channel number.

### **(4) S. BUS connection: RUD (Rudder) channel** RUD CH4

Using the [▲/+] or [▼/-] key to set the correct channel number.

### **(5) S. BUS connection: PIT (Pitch) channel** PIT CH6

Using the [▲/+] or [▼/-] key to set the correct channel number.





**(6) S. BUS connection: Rot HD Gn channel** RotHD.Gn CH9

Using the [▲/+] or [▼/-] key to set the correct channel number.



If the "Setup Style" setting of the "SWH BASIC" menu on page 45 is "F3C", it is necessary to set the aileron (Roll) gain and the elevator (Pitch) gain on separate channels. (Gain AIL and Gain ELE display)



**(7) S. BUS connection: Gain RUD channel** Gain RUD CH5

Using the [▲/+] or [▼/-] key to set the correct channel number.

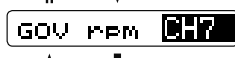

**(8) S. BUS connection: GOV rpm channel** GOV RPM CH7

Using the [▲/+] or [▼/-] key to set the correct channel number.

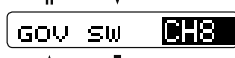

**(9) S. BUS connection: GOV sw channel** GOV SW CH8

Using the [▲/+] or [▼/-] key to set the correct channel number.

From 1/3

**SBUS BASIC screen 2/3**

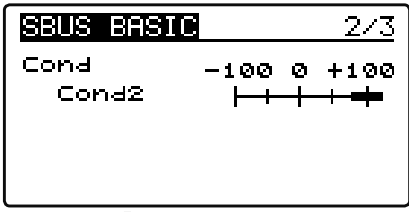

**(10) S. BUS connection: Condition on change channel** Cond DG1

Using the methodology described previously, determine the "Cond CH #" and use the [▲/+] or [▼/-] key to set the condition change channel of the transmitter. In this example, DG1 is the conditional change channel.



As with the flight condition function of the transmitter, it is possible to utilize pre-determined settings, each activated by a switch or switches on the transmitter. By setting the condition switch on the channel with the AFR function of the transmitter and setting the point for each flight condition with the AFR point curve, you can switch the condition of CGY760R in conjunction with the flight condition switch of the transmitter.

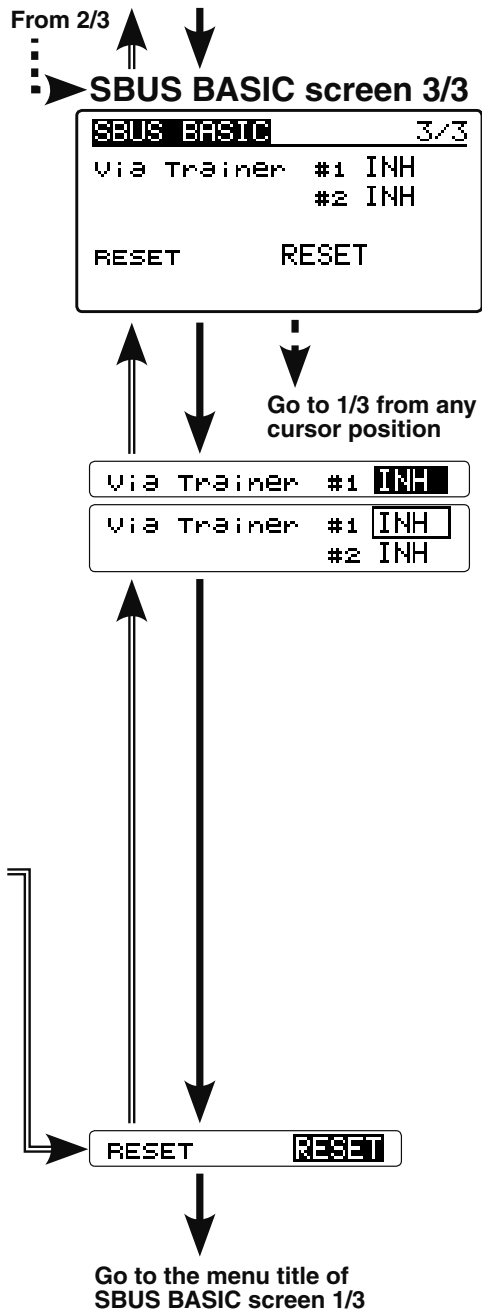

### (11) Via trainer channel

Via Trainer #1 INH

The transmitter's trainer channel uses two consecutive channels. For example, if CH11 is set to "# 1", CH12 is automatically set to "# 2". Therefore, when using this function, two consecutive free channels are required for the transmitter. It is not possible to use a channel assign that is used for another function. Move the cursor to "Via Trainer #" and press the [Enter] key to enter the setting mode. When "EXECUTE: Enter (1sec)" is displayed. Use the [▲/+ ] or [▼/- ] key to set the channels. Press the [Enter] key for about 1 second to set the channels for the programming via trainer from the transmitter.

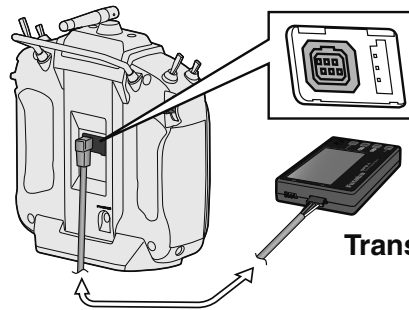

Trainer jack of the transmitter.

Transmitter Connection Cord

### ⚠ CAUTION

- ❗ Be sure to connect and disconnect the transmitter and GPB-1 connection cord with the power off.
- ❗ When changing "Via transmitter CH". Turn both the CGY760R and the transmitter off after changing the channel assignment. Until the gyro is power cycled, the wireless will not work.

### (12) RESET: S.BUS data reset

RESET RESET

```

EXECUTE: "Enter" (1sec)
Via Trainer #1 INH
Via Trainer #2 INH

RESET RESET

```

This resets the S.BUS channel assignments back to the defaults. Move the cursor to "RESET" by pressing the [▲/+ ] or [▼/- ] key, and press the [Enter] key to enter the reset mode. When "EXECUTE: Enter (1sec)" is displayed, press and hold the [Enter] key for about 1 second to initialize S.BUS channel setting. If you do not wish to reset to the default settings, press [Enter] key or [Esc/ Page] key to exit reset mode.

## About Transfer Function Of Gyro Setting Data

With this function, by connecting the transmitter and the GPB-1 with the transmitter connection cord, it is possible to wirelessly change the setting of the CGY 760R mounted on the model via the transmitter. For the list of functions that can be changed, refer to page 91. Before connecting the GPB-1 to the transmitter, please connect to the CGY 760R first and save the original data to the GPB-1 accordingly.

### Setting on transmitter side

1. Follow the transmitter's instruction manual, to set these items to the correct configuration. Use the TX's Function menu to set two consecutive free AUX channels to match the channel assignments set in the gyro SBUS menu. However, do not set the "Control" and "Trim" functions.
2. Set the two free channels to the following settings.  
Sub Trim: 0 / Fail safe: hold)/ Battery fail safe: OFF / Set the end point: 100  
The limit point: 155 (maximum) / Servo speed: 0 / Servo Reverse: Normal
3. Set the trainer function as follows according to the transmitter's instruction manual.  
Always ON  
Teacher / Student: -----Teacher  
Channel mode: -----16CH  
Mode for individual channels being used for gyro programming: ----- Normal  
Rate: ----- 100  
Point : In 12ch FASSTest mode only the first 12 channels can be used for wireless trainer. In 18ch FASSTest it is possible to use 18chs.

After connecting the GPB-1 to the transmitter via trainer port, power on the transmitter. Upon turning the transmitter "On" the GPB-1 will show the opening screen and the ID screen will be displayed. The ID number should be the same as the ID sticker on the CGY760R. If the ID numbers match, press and hold the [Esc/Page] key to display the trainer via function setting screen. **Note:** if the ID is different on the ID confirmation screen, connect CGY760R and GPB-1 to update the current set data of the CGY760R to GPB-1.

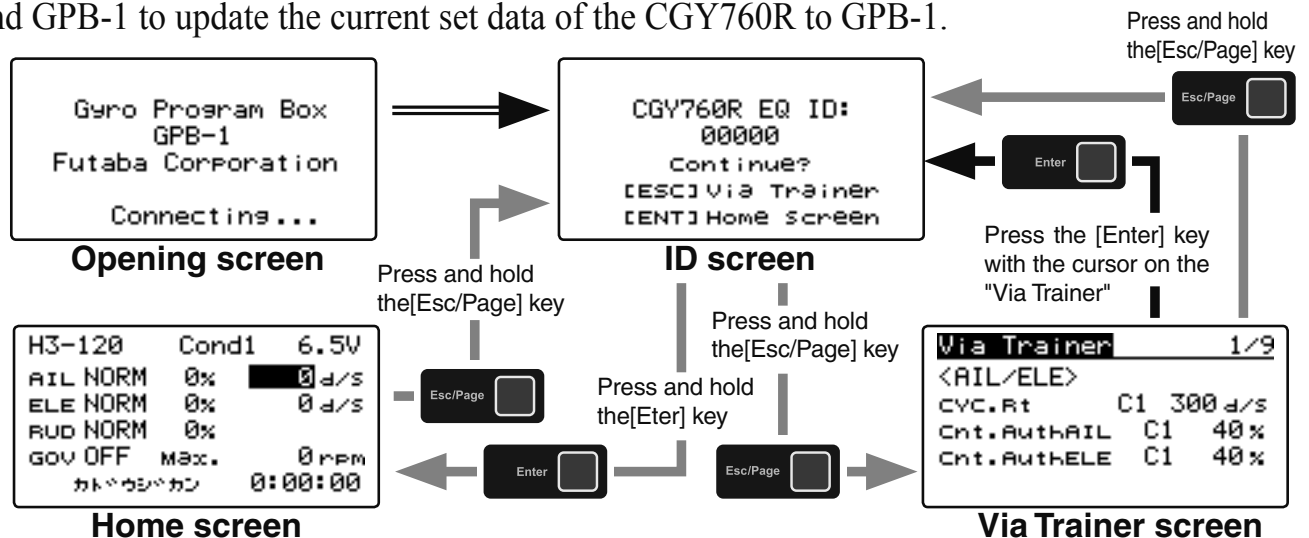

# SWH. BASIC MENU (SWASH BASIC SETTING)

This menu is utilized to perform the basic setup of swash motion. Refer to page 39 to display the "SWH. BASIC" screen from the "BASIC MENU" screen.

The CGY760R is compatible with the following six types swash plate.

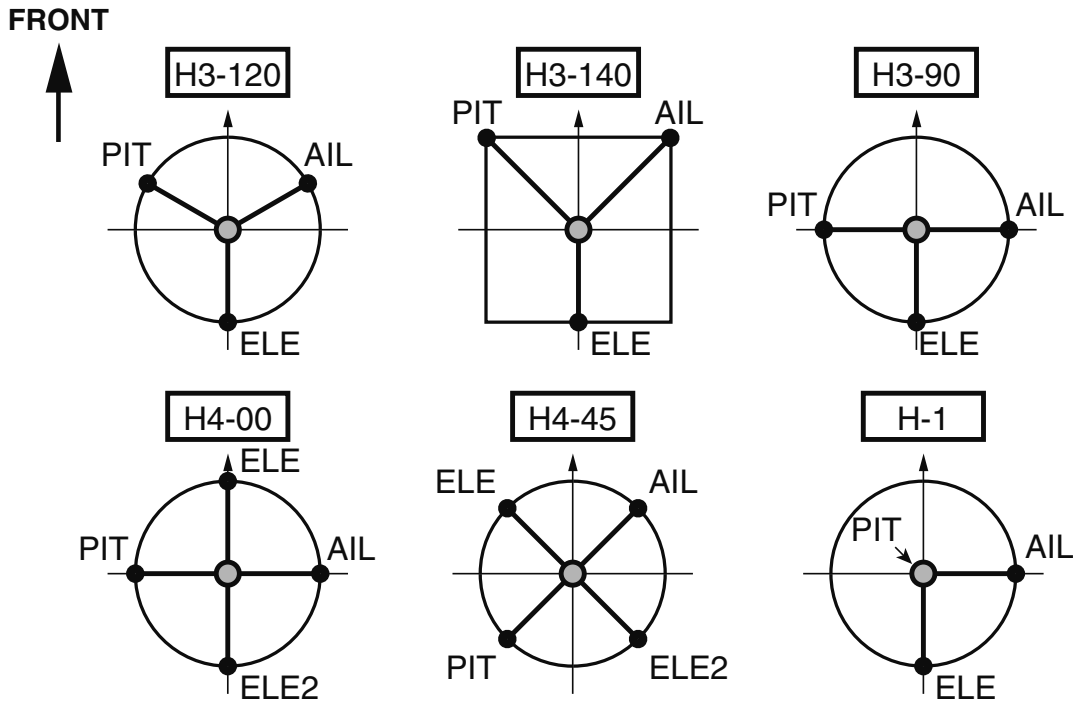

AIL-----Aileron servo  
 ELE----- Elevator servo  
 PIT-----Collective pitch servo  
 ELE2----- Second elevator servo

Your transmitter should be reset to the default settings and the swash plate type selected with the transmitter should be set to "H-1" or single servo mode. All CCPM mixing is set up and handled in the CGY760R, and the transmitter functions should not be used. Before starting model set-up, be sure that all dual rates, pitch curve, and endpoint values are set to 100/100.

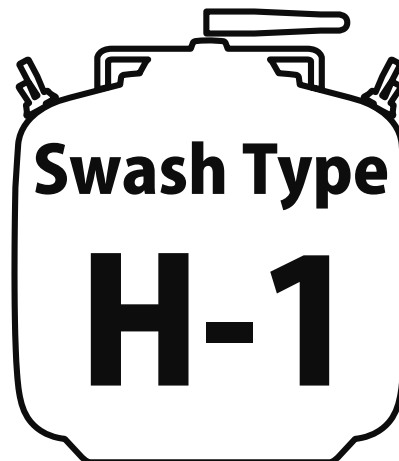

From 5/5 From the "Pit.Low" of SWH. BASIC screen 5/5

**SWH. BASIC screen 1/5**

```

SWH. BASIC 1/5
setup style 3D
Gyro set Dir 1
servo Type DG:285Hz
SWASH Type H3-120
servo Dir # 1
    
```

**⚠ WARNING**

⊘ Do not connect the servo to the gyros until you select the servo type in the "SWH. BASIC" menu.

\*If the servo type is incorrect, it is possible to damage the servos or CGY760R.

Go to 2/5 from any cursor position

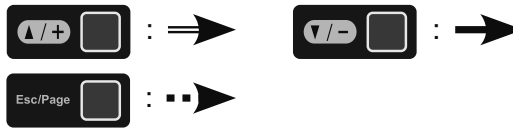

```

setup style 3D
    
```

**(1) Setup style** setup style 3D

3D mode contains a proven set of parameters which are good for not only 3D but also F3C flying. F3C Mode is for unique or special tuning types only.

\*The changed menu is indicated on a map.

\*When the style is changed, setting of AIL/ELE/RUD is re-initialized and defaults are changed.

Move the cursor to "Setup style" by pressing the [▲/+] or [▼/-] key and press the [Enter] key to enter the setting mode. Use the [▲/+] or [▼/-] key to set the style. When "EXECUTE: Enter (1sec)" is displayed. Press the [Enter] key for about 1 second to changes the selected style. The program will also exit the setting mode accordingly.

```

Gyro set Dir 1
    
```

**(2) Gyro Set Dir: Mounting direction** Gyro set Dir 1

Set the roll axis, pitch axis, yaw axis according to the mounting direction of CGY 760R. Set mounting direction with reference to page 18 - 19. Move the cursor to "Gyro Set Dir" by pressing the [▲/+] or [▼/-] key and press the [Enter] key to enter the mounting direction. Then select the mounting direction # with the [▲/+] or [▼/-] key. When you finish setting, press [Enter] key to exit setting mode. When the LED on the Gx side finishes blinking, please turn the power off and on again to confirm that it is working properly.

Setting: 1 ~ 6 Initial setting: 1

**⚠ WARNING**

If you do not turn the power back on after changing "Gyro Set Dir", the gyroscope will not operate properly, there is a risk of crashing.

servo Type DG:285Hz

**(3) Servo Type** servo Type DG:285Hz

This selects the swash servo types. There are four types or modes of the servo driving frequency selection, AN:70Hz, DG:95Hz, DG:140Hz, DG285Hz, and 760uS. All Futaba digital servos can be operated with fastest DG:285Hz mode but some of other brands of servos do not support DG:285Hz mode. In this case, select the proper servo driving frequency per the manufacturer's specifications. Move the cursor to "Servo Type" by pressing the [▲/+ ] or [▼/- ] key and press the [Enter] key to enter the setting mode. Then select the servo type with the [▲/+ ] or [▼/- ] key. When "EXECUTE: Enter (1sec)" is displayed, press the [Enter] key for about 1 second. This changes the selected type and exits the setting mode.

Setting: AN:70Hz/ DG:95Hz/ DG:140Hz/ DG:760µs / DG:285Hz Initial setting: DG:285Hz

**⚠ WARNING**

**❗ The servo type parameter within the CGY760R must match the type of servo you are using. Incorrect setting may damage the CGY760R or the servo. Incorrect setting may also result in a loss of control during flight.**

SWASH TYPE H3-120

**(4) SWASH Type: Swash change to plate type** SWASH TYPE H3-120

Select the swash plate type. Move the cursor to "SWASH Type" by pressing the [▲/+ ] or [▼/- ] key and press the [Enter] key to enter the setting mode. Then select the swash plate type with the [▲/+ ] or [▼/- ] key. When "EXECUTE: Enter (1sec)" is displayed, press the [Enter] key for about 1 second. This changes the selected type and exits the setting mode. When you change the setting, other data is initialized.

Setting: H-1/ H3-120/ H3-140/ H3-90/ H4-00/ H4-45 Initial setting: H3-120

**⚠ WARNING**

**❗ All of the swash plate parameters are reset when the swash plate type is changed. Doing so eliminates any possible errors or malfunctions within the system. After changing the swash plate type, Please proceed through the entire setup process once again before attempting to fly the model.**

↑ ↓  
 servo Dir # 1

**(5) Servo Dir #: Servo direction #** servo Dir # 1

Using different servo combinations will create the proper swash plate servo movement in electronic CCPM models (eCCPM). In the H3-xx swash mode, three of the swash servos directions are changed by pressing the [▲/+ ] or [▼/- ] key. Choose the combination number which produces level swash plate travel with a collective pitch input from the transmitter. There are 8 combination choices for the H3-xx swash mode. On H4-xx swash mode, there are 16 combination choices. After selecting the combination number, aileron, elevator, pitch, and 2nd elevator servo parameters are automatically set.

**Note:** Occasionally the aileron or elevator function directions are reversed even though collective pitch direction is correct. In this case, use the "SWS.Dir parameter on the following screen (3/5) to fix this later.

From 1/5

H1 or H3 SWH. BASIC screen 2/5 H4

SWH.BASIC	2/5
AIL.Ntr	+0
ELE.Ntr	+0
PIT.Ntr	+0

SWH.BASIC	2/5
AIL.Ntr	+0
ELE.Ntr	+0
PIT.Ntr	+0
ELE2.Ntr	+0

↑ ↓ → Go to 3/5 from any cursor position

AIL.Ntr +0

ELE.Ntr +0

PIT.Ntr +0

ELE2.Ntr +0

**(6) AIL, ELE, PIT. Ntr:**  
 Servo neutral adjustment

AIL.Ntr	+0	ELE.Ntr	+0
PIT.Ntr	+0	ELE2.Ntr	+0

Use the [▲/+ ] or [▼/- ] key to adjust the neutral position of the swash servo (aileron, elevator, pitch, second elevator). The second elevator (ELE2) is displayed only when the swash type is H4-xx.

Setting ranges: +240 ~ -240 Initial value: 0

ELE.2 is displayed only when the swash type is H4-xx

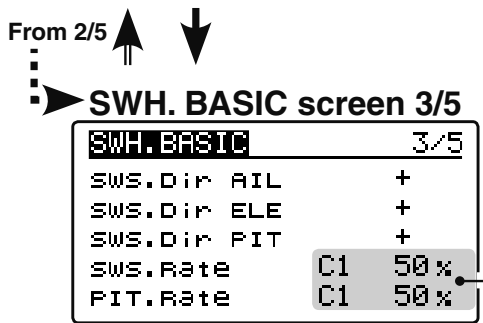

- \*The setting with "C#" display can be set for each condition.
1. Use the [▲/+ ] or [▼/- ] key to move the cursor to "C#" and press the [Enter] key to enter the condition selection mode. Use the [▲/+ ] or [▼/- ] key to select the condition number "C#" and press the [Enter] key to decide the condition number.
  2. Next, adjust value of the condition selected by the [▲/+ ] or [▼/- ] key, and press the [Enter] key to enter the setting mode. Use the [▲/+ ] and [▼/- ] keys to change the setting value. When you are done, press the [Enter] key to exit the setting mode.

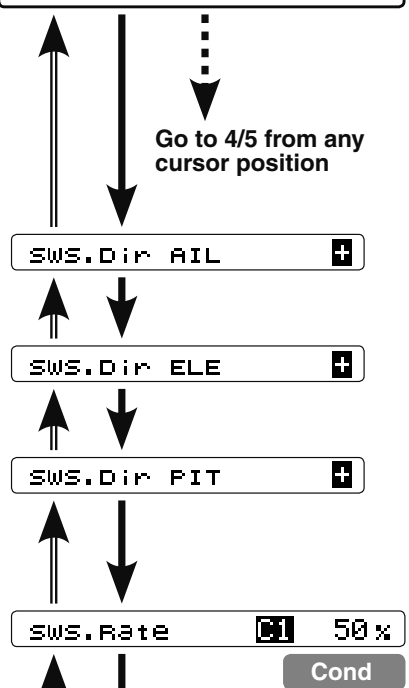

**(7) SWS. Dir: Swash direction setting**

```

SWS.Dir AIL +    SWS.Dir ELE +
SWS.Dir PIT +
  
```

This selects the aileron, elevator and collective pitch direction. Reverse the direction when the stick movement and swash movement are opposite. Each time you press the [▲/+ ] or [▼/- ] key, the polarity switches.

**(8) SWS. Rate: Rate adjustment**    SWS.Rate C1 50%

The Swash Rate settings are used to set a known base cyclic throw for the gyro to calculate the compensations and gain scale. This value does not represent the total cyclic throw, but rather shows the gyro a known point for the gyro to understand the helicopters geometry. It is important to note that one setting applies to both roll and pitch axes; they are not individually adjusted. Use the [▲/+ ] or [▼/- ] key to make an adjustment.

(DUAL RATES MUST BE 100)

- Suggested amount of base cyclic pitch
- \*800 size – 10 degrees
- \*700 size – 9 degrees
- \*600 - 550 size – 8 degrees
- \*500 size – 7 degrees
- \*450 and below- 6 degrees

**Setting ranges: 0 ~ 100%    Initial value: 50%**



PIT.Rate C1 50%  
Cond

**(9) PIT. Rate: Rate adjustment** PIT.Rate C1 50%

The [PIT.Rate] is the amount of collective pitch travel allowed. A good starting range for Sport, 3D and F3C is +/-10 to +/-12 degrees. Use the [▲/+ ] or [▼/-] key to make an adjustment.

Setting ranges: 0 ~ 100 Initial value: 50%

From 3/5

SWH. BASIC screen 4/5

SWH.BASIC	4/5
SWS.Ring	C1 130%
AGY.Dir	NORMAL
EGY.Dir	NORMAL
STK.Dir AIL	Rt
STK.Dir ELE	Bk

**(10) SWS. Ring** SWS.Ring C1 130%

This parameter is used to set the total maximum of cyclic throw as well as limit the swash travel to prevent binding of the swash plate servos when the control stick is moved toward a corner (for example, full right and full aft cyclic). Press the [▲/+ ] or [▼/-] key to adjust the value.

Setting ranges: 50 ~ 100% Initial value: 130%

SWS.Ring C1 130%

Go to 5/5 from any cursor position

**(11) AGy. Dir: Aileron (roll) Gyro direction**  
**EGy. Dir: Elevator (Pitch) Gyro direction**

AGY.Dir	NORMAL	EGY.Dir	NORMAL
---------	--------	---------	--------

AGY.Dir NORMAL

EGY.Dir NORMAL

This parameter controls which direction the CGY760R (roll / pitch axis) will compensate when the helicopter rolls (pitches). Pick the helicopter up and roll the helicopter to the right. The CGY760R should compensate by adding left cyclic to the swash plate. (Pick the helicopter up and rotate the nose of the helicopter downward. The CGY760R should compensate by adding aft cyclic to the swash plate.)

If the CGY760R compensates in the wrong direction, then it will be necessary to reverse the compensation direction setting by pressing the [▲/+ ] or [▼/-] key once.

**⚠ WARNING**

❗ Verify that the CGY760R compensates in the correct direction before flight. If the compensation direction is incorrect the model will roll or pitch uncontrollably even before it leaves the ground.

↑ ↓  
STK.Dir AIL Rt

**(12) STK. Dir AIL: Aileron operation** STK.Dir AIL Rt

Move the cursor to "STK. Dir AIL" by pressing the [▲/+ ] or [▼/- ] key and press the [Enter] key to enter the setting mode. When "EXECUTE: Enter (1sec)" is displayed, move the aileron stick to the full right direction. Pressing the [Enter] key for about 1 second will memorize the aileron's direction of motion.

↑ ↓  
STK.Dir ELE Bk

**(13) STK. Dir ELE: Elevator operation** STK.Dir ELE Bk

Move the cursor to "STK. Dir ELE" by pressing the [▲/+ ] or [▼/- ] key and press the [Enter] key to enter the setting mode. When "EXECUTE: Enter (1sec)" is displayed. Next, move the elevator stick to the full up direction. Pressing the [Enter] key for about 1 second will memorize the elevator's direction of motion.

Be sure to set this aileron motion direction and elevator motion direction so that F/F mixing (Ele Comp and Rud. F/F menu) works effectively. Also, please perform this operation after setting the direction of operation.

From 4/5

➔ **SWH. BASIC screen 5/5**

```
SWH.BASIC 5/5
Pit.High 1100
Pit.Zero 1520
Pit.Low 1940
```

Go to 1/5 from any cursor position

Be sure to perform "Pit.High", "Pit Zero" and "Pit Low" setting.

Pit.High 1100

**(14) Pit. High: Pitch high memorizing** Pit.High 1100

This parameter saves the full positive collective pitch point into the CGY760R. Move the cursor to "Pit. High" by pressing the [▲/+ ] or [▼/- ] key. Press the [Enter] key to enter the setting mode. "EXECUTE: Enter (1sec)" is displayed. Move the collective pitch stick to full positive pitch and pressing the [Enter] key for about 1 second. The full positive pitch signal will be saved to the CGY760R.

Pit.Zero 1520

**(15) Pit. Zero: Pitch zero memorizing** Pit.Zero 1520

This parameter saves the full positive collective pitch point into the CGY760R. Move the cursor to "Pit. Zero" by pressing the [▲/+ ] or [▼/- ] key. Press the [Enter] key to enter the setting mode. "EXECUTE: Enter (1sec)" is displayed. Move the collective pitch stick to 0 degree pitch and pressing the [Enter] key for about 1 second. The full positive pitch signal will be saved to the CGY760R.

Pit.Low 1940

**(16) Pit. Low: Pitch low memorizing** Pit.Low 1940

This parameter saves the full negative collective pitch point into the CGY760R. Move the cursor to "Pit. Low" by pressing the [▲/+ ] or [▼/- ] key. Press the [Enter] key to enter the setting mode. "EXECUTE: Enter (1sec)" is displayed. Move the collective pitch stick to full negative pitch and pressing the [Enter] key for about 1 second. The full positive pitch signal will be saved to the CGY760R.

Go to the menu title of SWH BASIC screen 1/5



# FLT. TUNE MENU (FLIGHT TUNING SETTING)

Flight tune sets control of helicopter roll (aileron) and pitch (elevator) axis. Refer to page 39 and display the "FLT. TUNE" screen from the "BASIC MENU" screen.



## FLT. TUNE screen 1/3

```

FLT. TUNE 1/3
Base gain 100%
CYC.Rt C1 300 d/s
  
```

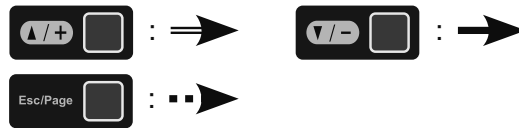

Go to 2/3 from any cursor position

```
Base gain 100%
```

### (1) Base. Gain: Gyro base gain setting

Base gain 100%

This sets the Cyclic Gyro Base Gain. If the Rotor Head Gain (Rot HD Gn) Channels are set to "INH" within the CGY760R "SBUS.BASIC" menu, then the remote transmitter gain adjustment is not available. Thus the actual working gain for the cyclic gyros is set by using the [▲/+] or [▼/-] key within this parameter.

Set to 100, a transmitter Gain value of 100% will display 100% on the GPB-1. If a pilot is in need of more gain, base gain can be increased to allow the gain on the CGY760R to be higher than 100%.

**Note:** If using a 6CH or less "Base Gain" is equivalent to the rotor head gain and can be adjusted manually on the gyro instead of via the transmitter.

Setting ranges: 0 ~ 150% Initial value: 100%

```
CYC.Rt C1 300 d/s
```

Cond

### (2) CYC. Rt: Cyclic rate setting

CYC.Rt C1 300 d/s

Cyclic rate sets the maximum Cyclic rate sets the maximum roll and flip rate (d/s) as limited by the model's ability to reach that set rate. Flip and roll rates are set together with this single parameter. The cyclic rate is set by using the [▲/+] or [▼/-] key.

Setting ranges: 10 ~ 500d/s Initial value: 300d/s

From 1/3

### FLT. TUNE screen 2/3

<b>FLT. TUNE</b>		2/3
Cnt. AuthAIL	C1	40%
Cnt. AuthELE	C1	40%
EXPO.	C1	-20%
FLT. Styl	C1	+50%

Go to 3/3 from any cursor position

Cnt. AuthAIL **C1** 40%

Cond

### (3) Cnt. AuthAIL: Control Authority Aileron

Cnt. AuthAIL **C1** 40%

Aileron Control Authority changes the rate at which the gyro will try to achieve the set "CYC. Rt". A higher value will create a quicker accelerated reaction to a stick input to reach and stabilize to the "CYC. Rt" value; a lower value will reach the desired "CYC. Rt" slower and accelerate slower to the desired angular rate.

**Note:** Setting this value too high could lead to a jerky feeling when making rapid stick corrections, a value too low will give you the impression the model is not following the pilot's stick inputs. Values of between 20-60 are the suggested range for most helicopters.

Setting ranges: 0 ~ 100%  
Initial value: Cnt. AuthAIL = 40%

Cnt. AuthELE **C1** 40%

Cond

### (4) Cnt. AuthELE: Control Authority Elevator

Cnt. AuthELE **C1** 40%

Elevator Control Authority changes the rate at which the gyro will try to achieve the set "CYC. Rt". A higher value will create a quicker accelerated reaction to a stick input to reach and stabilize at the "CYC. Rt" value; a lower value will reach the desired "CYC. Rt" slower and accelerate slower to the desired angular rate.

**Note:** Setting this value too high could lead to a jerky feeling when making rapid stick corrections, a value too low will give you the impression the model is not following the pilot's stick inputs. Values of between 20-60 are the suggested range for most helicopters.

Setting ranges: 0 ~ 100%  
Initial value: Cnt. AuthELE = 40%

EXPO. [C1] -20% Cond

**(5) EXPO.: Exponential** EXPO. [C1] -20%

Tune the exponential as desired to change the feel of the cyclic controls around center stick. Negative values soften control feel; Positive values increase sensitivity. The exponential rate is set by using the [▲/+ ] or [▼/- ] key.

**Note:** that any exponential present in the TRANSMITTER adds to the value set in the CGY760R.

Setting ranges: -100 ~ 0 ~ +100% Initial value: -20%

FLT.Styl1 [C1] +50n Cond

**(6) FLT. Styl: Flight style** FLT.Styl1 [C1] +50n

Increasing this value will create a more robotic reaction to the stick, leaving the pilot with the impression that the model is locked into in a position after an input. It will also tend to have a more calculated feeling when making inputs.

-Lowering the value will make the model feel more fluid and easy to rotate with the stick input. The model will feel a little more lively during faster cyclic movements and direction changes. Set by using the [▲/+ ] or [▼/- ] key.

Setting ranges: FLT. Styl [3D] = 0 ~ 100n Initial value: FLT. Styl [3D] = 50n

From 2/3

▶ FLT. TUNE screen 3/3

```

FLT. TUNE 3/3
ELE. Comp 0%
HP. Auth. 0%
  
```

▶ Go to 1/3 from any cursor position

**Note:** To effectively operate the next "ELE Comp" (elevator correction), make sure to set "Pit High", "Pit Zero", "Pit Low" on the "SWITCH BASIC" menu on page 51.



### ***(7) ELE. Comp: Elevator pre compensation***

A helicopter that has a head that rotates clockwise, will exhibit a tendency whereby the nose will be pulled towards the disk with positive blade pitch. Conversely, the helicopter will push the nose away from the rotor disk during negative pitch inputs. In an instance of a slower servo set-up or larger (heavier) rotor blades, a small amount of elevator pre compensation may be needed to keep the nose of the helicopter flat at all times during collective pitch changes. In most cases with helicopter high-speed servos and standard 3D rotor blades, this function is not needed. If you do notice a slight tendency for the nose to try to rise or fall with collective input, increasing "ELE Comp" will reduce this behavior.

**Setting ranges: 0 ~ 100% Initial value: 0%**



### ***(8) HP. Auth.: High pitch authority***

When a rotor blades angle of attack is increased, the rotor blade becomes less reactive, in turn the helicopter might not feel as reactive at high pitch angles. If you want to increase the reaction of the cyclic during loaded and high pitch maneuvers, "HP. Auth" will increase control authority and can be used to make the helicopter feel more linear under loading. Some helicopters with direct link CCPM may use this to increase stability at high collective pitch flying as well. If a helicopter feels good for normal flying, but not the same during loaded situations, "HP. Auth" can be used to make it feel more linear. If "HP. Auth" is set very high, the helicopter will feel more aggressive at high pitch than around neutral.

**Setting ranges: 0 ~ 100% Initial value: HP. Auth = 0%**

Go to the menu title of FLT. TUNE screen 1/3



## **RUD. BASIC MENU (RUDDER GYRO BASIC SETTING)**

In the "RUD. BASIC" menu, you make the basic setting of the rudder gyro. Refer to page 39 and display the "RUD. BASIC" screen from the "BASIC MENU" screen.

### **⊘WARNING**

⊘ Do not connect the tail rotor servo to the gyro until the servo type has been selected. Operating the servo using the incorrect setting may damage the CGY760R or the servo.

⊘ Do not operate with the linkage connected until the "Srv. Limit" function correctly sets the servo limit point. If the servo operates beyond the linkage operating range, there is a danger of either the servo or helicopter being damaged.

---

### **Setting on transmitter side**

The following transmitter setting example shows the case of using Futaba GY gyro mixing. Please read in accordance with your system.

1. Enable rudder gyro mixing.
2. In the gyro mode select "GY".
3. Temporarily set the gyro sensitivity of normal condition and hold condition to AVCS 75%. Also, temporarily set the gyro sensitivity of all idle up conditions to AVCS 50%.
4. Set the channel angle setting function (ATV / AFR / EPA) of the rudder channel and sensitivity setting channel to 100%.
5. Temporarily set the D/R function of the rudder channel to 75% both left and right.
6. We recommend that you temporarily set the EXP function of the rudder channel to about -30% (mild side 30%) need to clarify what is meant by mild side.

\* Please note that these are only the temporary settings. Final values will be determined during flight.



From 2/2 ... From the "Work Mode." of RUD. BASIC screen 2/2  
**3D RUD. BASIC screen 1/2**

```

RUD. BASIC 1/2
servo Type  DG:1520
Gyro Dir    NORMAL
Srv.Limit   100%
Srv.Limit   100%
  
```

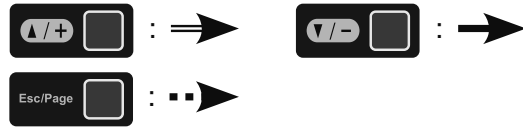

Go to 2/2 from any cursor position

### ⚠ WARNING

❗ The servo type parameter within the CGY760R must match the type of servo you are using. Incorrect settings may damage the CGY760R or the servo. An incorrect setting may also result in a loss of control during flight.

servo Type **DG:1520**

#### (1) Servo Type **servo Type DG:1520**

Select the appropriate setting for the tail rotor servo. Move the cursor to "Servo Type" by pressing the [▲/+] or [▼/-] key and press the [Enter] key to enter the setting mode. Then select the servo types: DG1520, DG760 or Analog with the [▲/+] or [▼/-] key. When "EXECUTE: Enter (1sec)" is displayed, press the [Enter] key for about 1 second to changes the selected type and exits the setting mode.

Setting: Analog / DG:1520 / DG760  
 Initial setting: DG:1520  
 DG 1520: BLS254, BLS257, S9254, S9257  
 DG 760: BLS276SV, BLS251SB, BLS251, S9256, S9251

Gyro Dir **NORMAL**

#### (2) Gyro. Dir: Gyro direction **Gyro Dir NORMAL**

This parameter controls which direction the CGY760R (yaw axis) will compensate when the helicopter rotates. Hold the tail rotor linkage over the linkage ball on the servo, pick the helicopter up by the main shaft and rotate the mechanics counter-clockwise. The CGY760R should compensate by adding clockwise rotation pitch to the tail rotor blades. If the CGY760R compensates by adding counter-clockwise rotation pitch to the tail rotor blades, then it will be necessary to reverse the Compensation Direction setting by pressing the [▲/+] or [▼/-] key.

Setting value: Normal / Reverse Initial value: Normal



### (3) *Srv. Limit: Limit setting*

Srv.Limit 100%

When the CGY760R is in the "Srv.Limit" parameter mode, the gyro will no longer operate and the tail servo will always center when the tail rotor stick is released. Always exit the setup functions before attempting to fly the model. Before each flight, always ensure that the gyros are operating and compensating in the correct direction. The Servo Limit parameter within the CGY760R is used to set the mechanical limits for the tail rotor servo. To obtain the best performance it is recommended to set the limit in the CGY760R to 100% for both directions and then adjust the servo arm length to set the mechanical endpoints. After that has been completed, use the servo limit parameter to make small adjustments that could not be made mechanically. Values between 90% and 110% are considered optimal. Hold the cursor to "Srv.Limit" by pressing the [▲/+ ] or [▼/- ] key. Gradually move the rudder stick to the left or right by the maximum amount the "►" cursor moves. Enter the setting mode by pressing the [Enter] key, increase or decrease the maximum throw using the [▲/+ ] or [▼/- ] key, and then press the [Enter] key to exit the setting mode. Set the same way on the other side. Ensure that the pitch slider does not bind at the maximum movement inputs.

#### **⚠ WARNING**

**❗** When using the CGY760R for the first time, or when making mechanical changes involving throw, you must check and set the servo limits again to prevent binding.

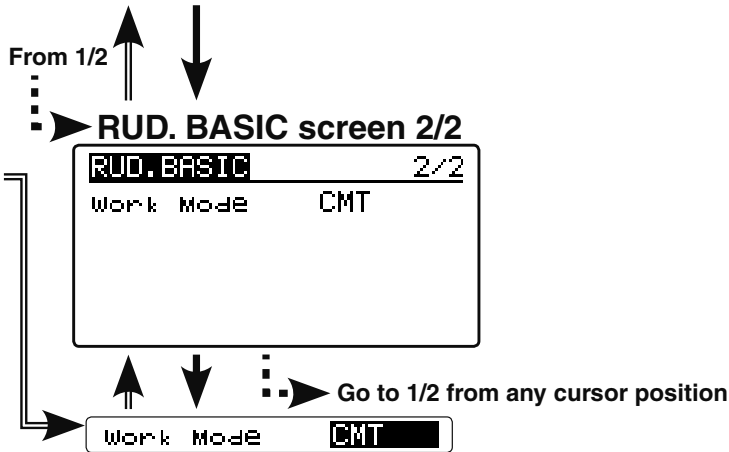

**(4) Work Mode: Gyro working mode**

Work Mode CMT

The available choices are CMT, Normal or AVCS. The CMT mode will allow you to select either AVCS or Normal mode via the transmitter. In Normal mode the gyro will always operate in Normal Rate Mode, and when AVCS is selected, it will always operate in AVCS Mode. Use the [▲/+] or [▼/-] key to select the desired working mode.

**Setting: CMT / Normal / AVCS Initial setting: CMT**

Go to the menu title of RUD. Basic screen 1/2

# Gov. BASIC MENU (GOVERNOR BASIC SETTING)

This menu sets the governor's fundamental functions. The menu Servo limit point setting must be set first. Refer to page 39 and display the "GOV. BASIC" screen from the "BASIC MENU" screen.

From 6/6 From the "SBUS2 rpm Slot" of GOV. BASIC screen 6/6

## GOV. BASIC screen 1/6

```

GOV.BASIC 1/6
Governor  ACT
gear Ratio 8.00t
Pole Num. 2p
servo Type Analog
    
```

**Note:** When using the governor function, be sure to make each setting of "GOV.BASIC".

**Note:** After completing the linkage of the throttle, be sure to set the "Servo limit point setting" first, and then set the other functions.

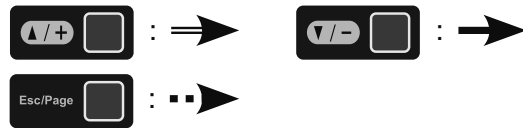

Go to 2/6 from any cursor position

Governor **ACT**

### (1) Governor: Governor active

Governor **ACT**

Set the governor operation mode of CGY760R. The initial setting is "ACT (active)" where, as the designation implies, the governor is active. If you do not want to use governor, select "INH (Inhibit)".

Setting: ACT (Active) / INH (Inhibit) Initial setting: ACT

gear Ratio **8.00t**

### (2) Gear Ratio: gear Ratio 8.00t

Input the main rotor gear ratio by pushing the [▲/+] or [▼/-] key to select the desired working mode.

Setting ranges: 1.00 ~ 50.00t Initial value: 8.00t

#### Notes:

- If the gear ratio is not properly set, the set speed and actual engine speed will be different.
- The gear ratio should be given in the helicopter instruction manual. If the helicopter instruction manual does not give the gear ratio, calculate the gear ratio as follows:

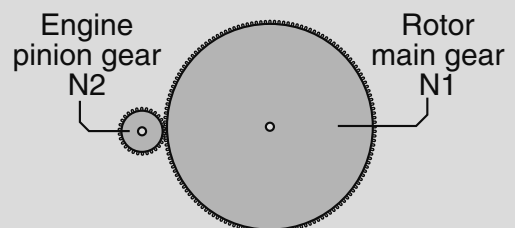

Gear ratio = N1/N2  
Carry values less than 1/1000 to the next whole number.

Pole Num. 2P

**(3) Pole Num.: Pole number** Pole Num. 2P

This parameter is used when using a direct phase sensor attachment to a brushless motor lead. Input the motor pole count as specified by the brushless motor manufacturer. When using any revolution sensor other than a direct phase sensor type, set the pole number to 2p.

**Note:** For nitro use, set to 2p.

**Note:** The input signal range of the CGY760R is 0.0v-3.0v. Exceeding this voltage range may cause damage to the CGY760R.

Setting ranges: 2 ~ 24P Initial value: 2P

servo type Analog

**(4) Servo Type** servo type Analog

Select the throttle servo type. Digital servos offer the best response. Move the cursor to "Servo Type" by pressing the [▲/+ ] or [▼/- ] key and press the [Enter] key to enter the setting mode. Select the servo type with the [▲/+ ] or [▼/- ] key. Pressing the [Enter] key exits the setting mode.

Setting: Analog / DG:1520 Initial setting: Analog

**⚠ WARNING**

**!** The servo type parameter within the CGY760R must match the type of servo you are using. Incorrect settings may damage the CGY760R or the servo. An incorrect setting may also result in the loss of control during flight.

From 1/6

**GOV. BASIC screen 2/6**

```
GOV. BASIC 2/6
RPM set 3 GvOff
stick SW ON 230%
ON/OFF SW INH
BAT F/S INH
```

**⚠ CAUTION**

**⊘** There is a danger of heavy loads being applied to the rotor rotating at high speed. Dropout of the rotor blade, damage of the head, etc., may occur. Do not set the rotation speed to a value that exceeds the strength limit of the helicopter and rotor.

Go to 3/6 from any cursor position

RPM set 1 1000 rpm    RPM set 2 1500 rpm    RPM set 3 2000 rpm

**(5) RPM set.: RPM setting**

RPM Set 1 1000 rpm

Setting the main rotor RPM. This is calculated by engine revolution with the gear ratio of the main shaft.

When the rotation speed can be set with the governor mixing function of the transmitter, it is necessary to first match the display rpm value of 1-2-3 of "RPM Set" with the display rpm value of the transmitter.

Setting ranges: off / 700 ~ 4,000 rpm Initial value: 1,000 rpm

\*To set lower than 1,000 rpm, set "Low. Revo" (page 90) of "GOV. EXPERT" menu to 700 rpm.

Stick SW OFF 0%

**(6) Stick sw.: Stick switch**

Stick SW OFF 0%

The governor can be activated by throttle stick position. Move the cursor to "Stick sw" by pressing the [▲/+ ] or [▼/- ] key and press the [Enter] key to enter the setting mode. "EXECUTE: Enter (1sec)" is displayed. Move the throttle stick to the desired governor on position. Press the [Enter] key for about 1 second, , memorizing that point.

This stick switch function is always enabled when the next "ON/OFF sw" is "INH" or the "Governor ON / OFF switch is not set by S.BUS setting.

**When governor is turned on and off by transmitter throttle stick**

The data is set so that the governor can be turned on and off with the transmitter throttle stick position. The following describes this operation.

- Throttle stick over set point and more than 60% of set rotation speed. →→→ ON

\*This is the setting value of "(9) Gov. On. Revo: Governor ON revolution setting" on page 89.

- Throttle stick held at the set point or more Remains. →→→ ON
- Throttle stick position is below the set point selected. →→→ OFF

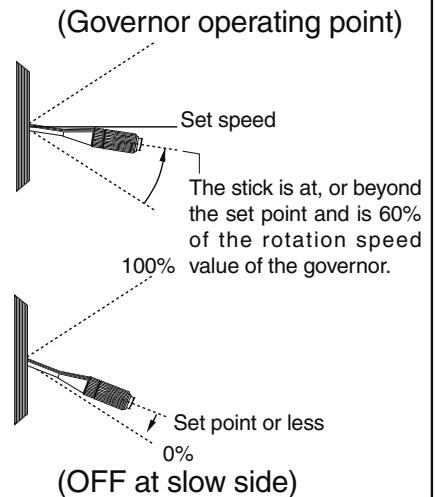

**When idle up**

- When the throttle curve is set at idle up, and when the throttle output is over the set value (initial value: 30%), the governor will always and remain ON even if the stick is lowered to the bottom.



**(7) ON/OFF sw.: Governor on/off switch** ON/OFF SW INH

This parameter allows the user to turn the governor on or off via a switch on the transmitter. Pressing the [▲/+] or [▼/-] key activates the function. Choose INH if you do not want to use it.

**When turning on / off governor with switch**

Select the ON / OFF switch channel with "GOV sw channel" on "SBUS BASIC" menu on page 41.

Setting the switch to the ON position turns on, or enables the governor. The following describes this operation.

- Switch set to on position and engine running at 60% (see page 89) or more of set speed →→→ ON
- Throttle stick set to maximum slow position →→→ ON
- Switch set to off position →→→ OFF

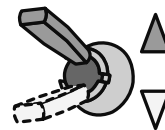

Governor can be turned on and off by a switch.

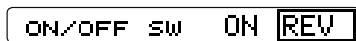

When you activate the switch, the direction setting of the switch is displayed. Select the switch ON / OFF direction (NORM / REV) with the [▲/+] or [▼/-] key.

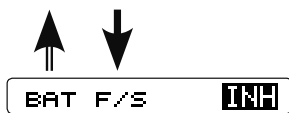

**(8) BAT F/S: Battery fail safe** BAT F/S INH

When the receiver battery voltage becomes equal to or less than "BFS. Volt" (page 90) set in the "GOV EXPERT" menu, the battery fail safe function is activated, the governor function is turned OFF, and the throttle servo moves to the set position.



When the setting is completed, the "!" Mark is displayed.

When Battery Fail Safe is enabled, items for setting the throttle servo position are displayed. The setting method is the same as "Stick sw", so please refer to this section of the manual for information on setting this function.

If the battery voltage is lower than the set voltage of the "Battery F/S" for about 3 seconds, the Gx (gyro) LED of the CGY 760R solid red light. When "Battery F/S" is set to "ACT" in "GOV BASIC", the servo is fixed to the throttle position set by "Battery F / S".

When the throttle stick is set to the slowest position, the "Battery F/S" function is temporarily canceled. However, after 30 seconds, the "Battery F/S" function is activated again and the servo is locked. When the "Battery F/S" operates, quickly landing and stopping the helicopter, please charge the battery.

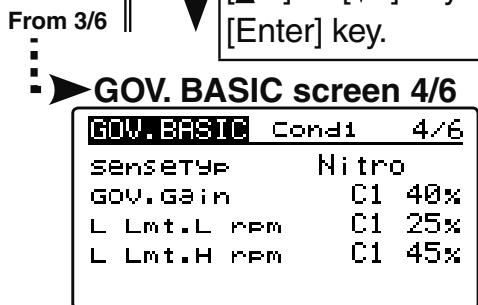
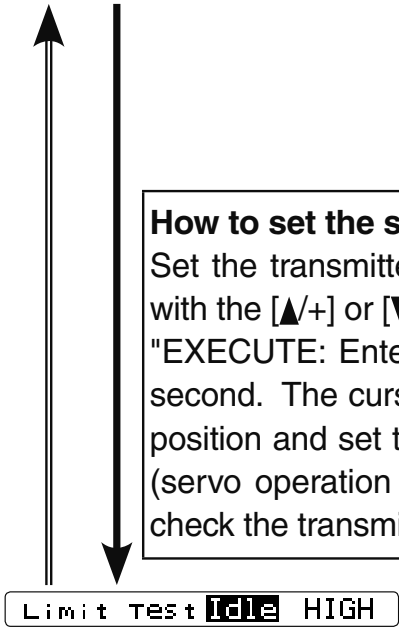
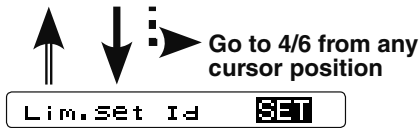
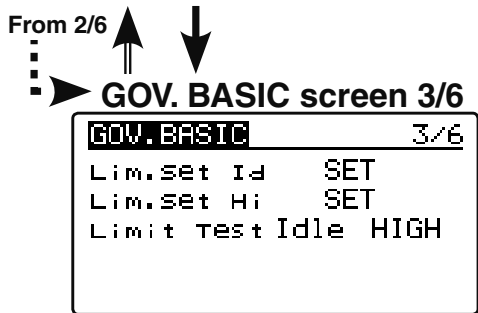

## ⚠ WARNING

❗ When using the CGY760R for the first time, or when making changes in the throw of a servo and its linkage, always perform the limit setting operation.

### (9) Lim. set: Servo limit point setting

```

Lim.set Id SET Lim.set Hi SET
  
```

Servo limit point setting defines the overall travel range for the throttle servo. It is fundamental for governor operation and must be set prior to other functions. Servo limits must also be reset when the throttle linkage or trim are changed. Refer to the next page for setting procedures and adjustments.

#### How to set the servo limit point:

Set the transmitter's throttle stick to the idle position. Select [Lim. Set Id] with the [▲/+] or [▼/-] key and press the [Enter] key to enter the setting mode. "EXECUTE: Enter (1sec)" is displayed. Press the [Enter] key for about 1 second. The cursor will move to "Lim. Set HI". Set the stick to the full high position and set the same as "Lim. Set Id". If the setting data is not normal (servo operation amount is 50% or less), "Err" is displayed. In this case, check the transmitter setting and repeat this procedure once again.

### (10) Limit Test: Check the set limit point

```

Limit Test Idle HIGH
  
```

Check the set limit point. Use the [▲/+] or [▼/-] key to move the cursor to "LIMIT Test Idle" and press the [Enter] key to move the servo to the idle point "END" will be displayed on screen. Similarly on the high side, use the [▲/+] or [▼/-] key to select the cursor "LIMIT Test HIGH" and test it with the [Enter] key.

\*The setting with "C1" display can be set for each condition.

1. Use the [▲/+] or [▼/-] key to move the cursor to "C#" and press the [Enter] key to enter the condition selection mode. Use the [▲/+] or [▼/-] key to select the condition number "C#" and press the [Enter] key to decide the condition number.
2. Next, adjust value of the condition selected by the [▲/+] or [▼/-] key, and press the [Enter] key to enter the setting mode. Use the [▲/+] and [▼/-] keys to change the setting value. When you are done, press the [Enter] key to exit the setting mode.



senseTyp Nitro

**(11) SenseTyp: Sensor type** senseTyp Nitro

Select the type of governor sensor.  
 Nitro (BPS-1 backplate; Magnet Type)  
 1:1 Magnet "1:1 Mag" (Magnet type applied to helicopter part that turns at the same RPM as the main rotor)  
 HPoleEP: For Electric motors 8 poles and above  
 LPoleEP: For electric motors 6 poles.

GOV.Gain 40% Cond

**(12) GOV Gain: Governor gain** GOV.Gain 40%

Governor Gain. If the value of the Governor Gain is set too low, the helicopter's RPM will fluctuate with collective and cyclic pitch changes. Conversely, if the number is too high, the RPM itself will fluctuate and surge during flight.

Setting ranges: 1 ~ 100%  
 Initial value: Nitro = 40%, 1:1Magn = 60%, HPoleEP= 30%, LPoleEP = 10%

L Lmt.L rpm 25% Cond

L Lmt.H rpm 45% Cond

**(13) L Lmt. Hov / Idle : Low limit RPM**

L Lmt.L rpm 25% L Lmt.H rpm 45%

Low RPM Limit sets the minimum amount of throttle that the governor will command during an over-speed situation. Too low of value the engine could shut off or not recover power quickly enough during the next collective movement. If the value is set too high, the governor will not control overspeed when the rotor head is unloaded.

Use:  
 L Lmt. Hov: For RPMS of 700-1700  
 L Lmt. Idle: For RPMS of 1701-4000

Setting ranges: L Lmt. Hov = 0 ~ 80%, L Lmt. Idle = 10 ~ 80%  
 Initial value: L Lmt. Hov = 25%, L Lmt. Idle = 45%

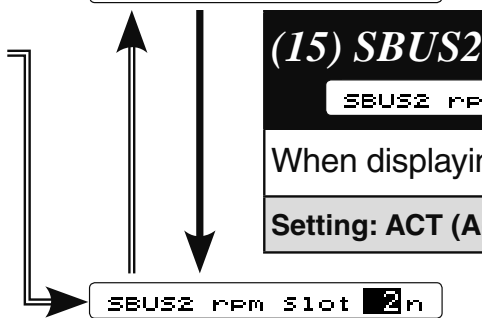
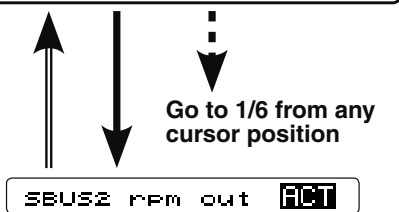
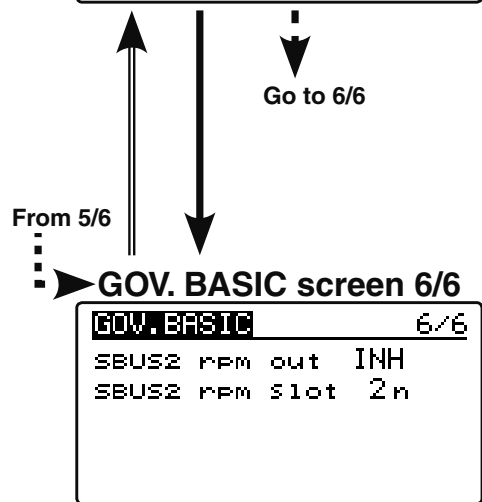
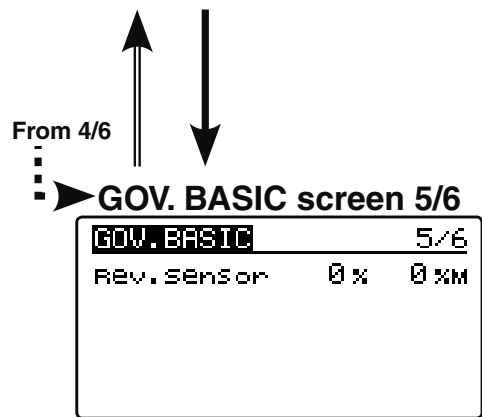

**(14) Rev. Sensor: Revolution sensor testing**

This menu is utilized to ensure that the revolution sensor is functioning properly. The display for this testing is found in: GOV BASIC 5/6.

In order to test the sensor, do NOT start the engine. Instead, we recommend turning the engine over by hand or the utilization of a starter. To prevent inadvertent ignition of the engine, do NOT use a glow plug igniter when turning the engine over.

The numerical values on the left side of the display are the current value. The right side of the display indicates the maximum sensor value. The output level needs to be more than 60% for correct governor operation. Also, when using the backplate sensor, the signal level of the backplate sensor varies depending on the rotation speed (3,000 rpm or more is the detectable rotation speed).

By the telemetry function, the number of revolutions read by the governor sensor can be displayed on the monitor of the transmitter. In order to be able to display, activate the telemetry rotation sensor (SBS-01RM) on the transmitter and set the gear ratio to 1.00.

**Note:** It can not be used when the transmitter is FASSTest 12CH system.

**(15) SBUS2 rpm out: RPM display on transmitter**

SBUS2 rpm out ACT

When displaying the rpm with the telemetry function, set it to ACT.

Setting: ACT (Active) / INH (Inhibit) Initial setting: INH

**(16) SBUS2 rpm Slot: RPM display on transmitter**

SBUS2 rpm out ACT

Set the slot number of the telemetry rotation sensor registered on the transmitter side.

Go to the menu title of GOV. BASIC screen 1/6

## ***Governor Speed Setting***

If the governor switch is ON when the power is turned ON, the governor will not turn ON.

Once you turn off the ON state, the governor is ready for operation. Always turn off the governor when starting the engine.

The CGY760R's rpm selection is accomplished by setting the channel in section (8) "RPM channel" menu located within the "S.BUS Basic Setting" to the governor speed setting channel of your system (page 41). When using an independent governor on/off switch, activate the section (7) "Governor on/off switch" function within the "Governor Basic Setting" section earlier in this manual (page 63).

### **Direct set by transmitter on Gov. mixing**

- When governor mixing is used to switch the RPM of the rotor head speed, the head speed can be switched with each condition of the switch.

\*For a description of the governor mixing, please refer to your transmitter's manual.

### **Using by 3 position switch**

- Set the RPM at each switch position in the "(5) RPM setting" menu within the "Governor Basic Setting" section earlier in this manual (page 62).

## ***Governor operation***

The CGY760R operates from 700 to 4000 rpm main rotor speed. However, the engine must be running at the set speed. The CGY760R turns off the governor when the engine is starting or idling.

### **Condition of the governor to be on**

For safety purposes, the governor is turned on when the conditions below are satisfied.

- The on/off switch conditions are set to off during power on.
- The stick switch is in the on position when it is used.
- The on/off switch is in the on position when it is used.
- Setting speed is not off.
- The engine speed exceeds to 60 % of the setting speed.
- The speed sensor is working properly.

## **⚠️ WARNING**

**⚠️ Safety reminder: Remember to configure your transmitter fail safe settings for not only the throttle channel but also the governor ON/OFF channel to ensure that the governor correctly disengages should the radio enter a fail safe condition.**



## RECOMMENDED GYRO GAIN SETTINGS

---

### *Recommended gain settings:*

The optimum sensitivity is the position just before the gyro starts hunting. To achieve this optimum setting, it is necessary to adjust the gyro gain settings after actually flying the helicopter.

Size	Recommended Gyro Gain	
	Rotor Head Gyro	RUD Gyro
450-550	45 ~ 55%	45 ~ 55%
600-700	50 ~ 60%	50 ~ 60%
750-more	55 ~ 65%	55 ~ 65%

\*50% is a good starting point for rudder gain regardless of model size.



## ADJUSTMENTS DURING THE TEST FLIGHT

---

### *Pre-flight checklist*

- Check that the transceiver's battery is fully charged.
- Check whether the gyro tape is torn or peeled.
- Turn on the transmitter / receiver and initialize the gyroscope.
- Check whether the servo type setting matches the servo being used (Rudder / Swash).
- Check that the servo horn is neutral and perpendicular to the push rod. (Rudder / Swash).
- Confirm that the maximum servo movements are not physically bound throughout the range of motion. (Rudder and swash).
- Check that the gyro is operating in the correct mode (AVCS or normal) (Rudder).
- Check whether the operation of each input matches the operation of the tail rotor / swash plate.
- When rotating the aircraft body, make sure that corrective action is performed in the correct direction.
- Is the gyro sensitivity set correctly for all flight conditions? Also, check whether it is operating in the correct mode (AVCS or normal).

## **⚠️ WARNING**

**❗ Always level the swash plate using the cyclic stick before applying throttle and spooling up the main rotor blades. During takeoff small corrections may be necessary. If you make large corrections while the helicopter is on the ground, it may tip over since the helicopter is firmly on the ground and the gyros are over-compensating due to the lack of movement.**

**❗ Some helicopters may have a tendency to resonate/shake during spool up. Always leave the helicopter on the ground until this resonance or shaking goes away. If this issue continues, it is recommended to try some rubber skid stops or take off from a softer surface such as grass. Vibrations contribute to this ground resonance. Verify that everything on your model is balanced correctly.**

\*When the CGY760R is used with an ESC or BEC and a power switch is not used, there is a possibility of an intermittent connection when connecting the flight battery. This may cause the CGY760R initialization to fail. Always ensure that the gyro has initialized properly by verifying that the gyros are compensating as the helicopter is moved. It is recommended to use a power switch on the power supply line to avoid this possibility.

### ***Rudder Gyro Trim Flight:***

The tail rotor/rudder AFR or D/R function within the transmitter is used to adjust the pirouette rate of the helicopter to suit your requirements. Do NOT use ATV or rudder channel travel adjustment for this purpose. For optimum performance, the tail rotor should be trimmed in Normal/Rate mode as closely as possible with adjustments to the tail rotor pushrod length before finalizing with transmitter trim and then memorizing that value into the CGY760R.

The tail rotor gyro gain should be raised until the tail begins to oscillate quickly (also called tail "wag"). Once this point has been achieved, reduce the gain as needed a few percent at a time to eliminate the oscillation. Repeat the process for all flight conditions. The main rotor speed, tail rotor ratio, tail rotor pitch range and tail blade length play a large part in achieving optimum tail rotor performance. The gain value can vary drastically from model to model, and the exact value should not play a part in the evaluation of the gyro's performance.



## TIPS FOR USING THE GOVERNOR WITH ELECTRIC MODELS

### WARNING

**❗ Safety Reminder: Remove both main and tail blades from the model and/or disengage the motor's pinion from the main gear before proceeding with any electric governor set up.**

- Make sure your ESC is configured for external governor use. Refer to the owner's manual for your ESC.
- You may use either a brushless phase sensor or the traditional governor magnetic sensor with a magnet mounted in a collar on the main shaft or in the main gear. With one magnet, set the gear ratio to 1:1.
- When choosing a brushless phase sensor, observe the input signal range of the CGY760R specified in the Governor Basic section.
- Refer to the manufacturer's documentation for your electric motor to select the correct pole count when using a brushless phase sensor. Pole count is set to 2 when using a magnetic sensor.
- Set the governor Working Mode (Wrk.Mode) in "GOV EXPERT" menu.
- Set the servo type (ServoTyp) to DG:1520.
- Make sure you correctly calibrate your ESC.
- Make sure you calibrate the governor speed ranges in the transmitter's governor menu and set the high and low limits for throttle in the Governor Basic menu.
- If a tail "kick" or "jerk" is observed when switching from one idle-up head speed to another, INCREASE the Revolution Up and Down delays (Revo.Up Dlyo/Revo.Dn Dly – "GOV. EXPERT" Menu). Increase 2-5% at a time until the tail "kick" is suppressed.
- The greater the electronic speed control headroom built into the model as a function of its gearing, the more prone the tail will be to kicking with aggressive flying. Models geared for high head speed but flown aggressively at low head speed present the greatest challenge for the governor. The more optimally your model is geared for your chosen head speed, the better the governor will function.
- Excessive governor gain worsens tail kick. Use as little gain as necessary for adequate head speed control.
- If the model yaws nose left with aggressive collective input, activate and adjust the PIT→RUD F/F (feed forward) mixing. Increase in 2-5% increments. F/F mixing should ADD pitch to rudder with added positive or negative collective pitch assuming a CW main rotor direction.



# TRANSMITTER Rotor head Gyro GAIN SET-UP

*Transmitter Set-up for adjusting cyclic gains via the transmitter.*

---

## Using the Remote Gain Functions (roll, pitch and yaw)

1. Some Futaba transmitters contain auxiliary gain functions for aileron, elevator and yaw. Please refer to your transmitter's instruction manual. Assign the Gyro (RUD), Gyro (Rotor Head replaces AIL/ELE) channels within the transmitter. Within the CGY760R "S.BUS BASIC" menu → Rotor Head Gyro Gain – In the SBUS menu assigning "Rotor Head gain" to a channel will allow the Rotor head gain to be adjusted via the transmitter. If you are using a 5 or 6CH transmitter, setting "Rotor Head gain" to "INH" will then default the gain to "BaseGain" in the "FLT. TUNE" menu. Suggested setting and default is CH9. Tail Rotor Gain "Gain RUD" – In the SBUS menu assigning "Gain RUD" to a free transmitter channel will allow for the tail rotor gain to be adjusted via the transmitter. Suggested setting and default is CH5.
2. The gyro function within your transmitter should list all three gain channels. Adjustments can be made from within this function. The gyro function can usually be assigned to various switches or conditions to offer greater adjustability. Please refer to your transmitter's instruction manual for further details.

### **WARNING**

**! Verify that the gyro compensates in the correct direction for all three axes before flight. If the compensation direction is incorrect, the model will roll, flip, or pirouette uncontrollably even before it leaves the ground.**

---

## Setting the CGY760R gains by using endpoints or manual adjustments

1. If your transmitter does not support the remote gain adjustment it is still possible to use a spare channel on the transmitter to make the adjustments. Assign unused channels (verify that these channels are not assigned or operated by a switch or dial) within the transmitter. Set the "Rotor Head gain" channels in the "S.BUS.Basic" menu to the appropriate channel. Use the end point adjustment within your transmitter for these channels to make the gain adjustments and the reverse function within the transmitter to set the mode "AVCS/NOR". Conditions with the transmitter may also be used to achieve different gains based upon flight modes. Please refer to your transmitter's instruction manual for further details.
- 

## Manual gain adjustment

1. If your setup does not leave any channels free, or if your transmitter does not support auxiliary gain adjustment, then it is possible to adjust the gain manually within the CGY760R. Set both the "Rotor Head gain" in the "SBUS. BASIC" menu to "INH". The gain adjustments are now made by entering the "BaseGain" in the "FLT. TUNE" menu and pressing the [▲/+ ] or [▼/- ] key.

# EXPERT MENU

This menu enables the user to further refine the gyro and governor settings.

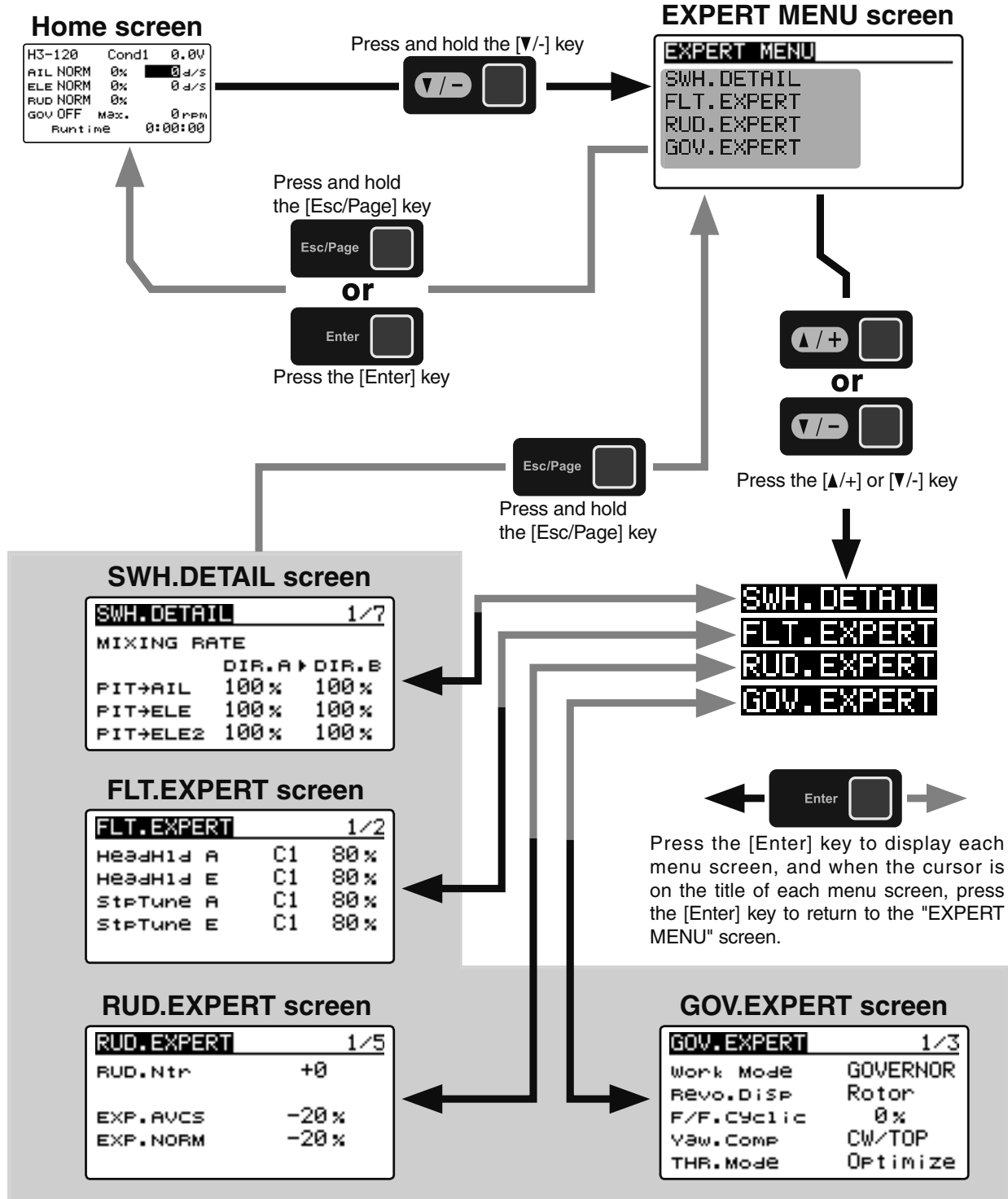



# RUD. EXPERT MENU (RUDDER GYRO EXPERT SETTING)

The rudder Expert menu allows for further refinement of the tail rotor gyro performance. Refer to page 72 and select the "RUD. EXPERT" screen from the "EXPERT MENU 3D" screen.

From 5/5  From the "Sens. Model" of RUD. EXPERT screen 5/5

## RUD. EXPERT screen 1/5

RUD. EXPERT	1/5
RUD. Ntr	+0
EXP. AVCS	-20%
EXP. NORM	-20%



   Go to 2/5 from any cursor position

RUD. Ntr

### (1) RUD Ntr: Rudder servo neutral setting

RUD. Ntr

This parameter is used to set the neutral position of the rudder servo. Position the rudder servo arm as perpendicular as possible to the tail rotor pushrod prior to making adjustments with this parameter. Move the cursor to "RUD Ntr" with the [▲/+ ] or [▼/- ] key and press the [Enter] key to enter the setting mode. Adjust the neutral position with the [▲/+ ] or [▼/- ] key. When you finish adjusting, press [Enter] key to exit setting mode.

Setting ranges: -240 ~ 0 +240 Initial value: 0

EXP. AVCS

EXP. NORM

### (2) EXP. AVCS / EXP. NORM: Rudder exponential

EXP. AVCS  EXP. NORM



This parameter sets the feel of the tail rotor control around center. When set to [0] the control curve is linear. Using a [+] value the tail rotor will be more sensitive around neutral conversely, using a [-] value will soften the feeling around neutral. The RUD EXP parameter in your transmitter can also be used to tune the tail rotor to a desired feeling.

Setting ranges: -100 ~ 0 +100% Initial value: AVCS = -20% , NORM = -20%

Sports = AVCS -60% / NORMAL -40%, 3D = AVCS -20% / NORMAL -20%>

From 1/5    
 **RUD. EXPERT screen 2/5**

<b>RUD. EXPERT</b>	2/5
CNT.D1In	▶ 15n
CNT.D1In	15n
CNT.D1Out	▶ 12n
CNT.D1Out	12n

  Go to 3/5 from any cursor position

CNT.D1In ▶ 15n

**(3) CNT. DIIn: Control delay in** CNT.D1In ▶ 15n

This parameter sets the delay as you move the stick from neutral toward left or right. Larger values result in a softer tail rotor feel off center. This parameter must be adjusted individually for LEFT and RIGHT tail rotor commands. Hold the cursor to "CNT. DIIn" by pressing the [▲/+] or [▼/-] key. Move the rudder stick to the left or right by amount the "▶" cursor moves. Enter the setting mode by pressing the [Enter] key, adjust the amount of delay with the [▲/+] or [▼/-] key, and then press the [Enter] key to exit the setting mode. Follow these same procedures to adjust the tail rotor feel in the opposite direction.

Setting ranges: 0 ~ 20 n Initial value: 15 n

CNT.D1Out ▶ 12n

**(4) CNT. DIOut: Control delay out** CNT.D1Out ▶ 12n

This parameter sets the delay when the stick is returned back to the neutral position. This parameter is useful to tune how aggressively the tail rotor stops following a pirouette. The higher the value, the softer the stop. This parameter must be adjusted individually for LEFT and RIGHT tail rotor commands. The setting method is the same as "CNT. DIIn", so please refer to the information above.

Setting ranges: 0 ~ 20 n Initial value: 12 n

From 2/5  
 RUD. EXPERT screen 3/5

```

RUD. EXPERT 3/5
ANG          720 d
  
```

```

ANG 720 d
  
```

**(5) ANG: Pirouette speed** ANG 720 d

This parameter adjusts the maximum pirouette speed of the tail rotor that the gyro will allow at 100% dual rate. Use the [▲/+] or [▼/-] key to adjust the maximum commanded pirouette rate.

Setting ranges: 100 ~ 999 d Initial value: = 720 d,

From 3/5  
 RUD. EXPERT screen 4/5

```

RUD. EXPERT 4/5
F/F.Rate U   +0%
F/F.Rate D   +0%
ACC.Gain     0%
  
```

```

F/F.Rate U +0%
  
```

```

F/F.Rate D +0%
  
```

**(6) F/F.Rate U / F/F.Rate D: F/F mixing rate**

F/F.Rate U +0% F/F.Rate D +0%

Feed Forward mix is used to counteract sudden increases in torque from the motor during fast collective pitch changes. If you notice a tail kick, using (right rudder on Clockwise rotor disk, left rudder on CCW) F/F mixing can be tuned to reduce the tail kick. The mixing amount can be individually set for high pitch side (U) and low pitch (D) side with zero pitch as the center.

Setting ranges: -100 ~ 0 ~ +100% Initial value: +0%

↑ ↓  
ACC.Gain 0 %

### (6) ACC Gain: F/F mixing acceleration gain

ACC.Gain 0 %

In low head speed situations where a lot of F/F Mixing might be needed, acc. gain boosts the input and removes it immediately after to help cure the sudden change in torque, but it does not allow the large tail rotor input to alter the axial behavior of the helicopter.

Setting ranges: 0 ~ 200% Initial value: 0%

From 4/5

### RUD. EXPERT screen 5/5

```
RUD. EXPERT 5/5
Tail RESP. 1
RESET RUD. Gyro
```

↑ ↓ → Go to 1/5 from any cursor position  
Tail RESP. 1

### (7) Tail Resp: Tail response

Tail RESP. 1

The goal is to match the response between the helicopter tail response and the gyro control. This feature is utilized to do so. 1 is the fastest response. Generally, if the tail response is slow or the servo's speed is slow, setting the tail response setting late will increase the gyro sensitivity and improve the control performance. Also, if the response setting is delayed, the power consumption of the servo will be reduced. However, if the response setting is too late, the operation cannot keep up with high-speed operation of the helicopter.

Setting ranges: 1 ~ 5 Initial value: 1

↑ ↓ → RESET RUD. Gyro

### (8) RESET : Rudder gyro data reset

RESET RUD. Gyro

This resets the "RUD.EXPERT" setting back to the defaults. Move the cursor to "RESET" by pressing the [▲/+ ] or [▼/- ] key, and press the [Enter] key to enter the reset mode. When "EXECUTE: Enter (1sec)" is displayed, press and hold the [Enter] key for about 1 second to initialize "RUD.EXPERT" setting. If you do not wish to reset, press [Enter] key or [Esc/Page] key to exit the reset mode.

Go to the menu title of RUD. EXPERT screen 1/5



# FLT. EXPERT MENU (CYCLIC GYRO EXPERT SETTING)

The "FLT.EXPERT" menus allow further refinement of cyclic gyro performance. Refer to page 72 and display the "FLT. EXPERT" screen from the "EXPERT MENU 3D" screen.

From 2/2 From the "RESET" of FLT. EXPERT screen 2/2

## FLT. EXPERT screen 1/2

HeadHld A	C1	80%
HeadHld E	C1	80%
StpTune A	C1	80%
StpTune E	C1	80%

- \*The setting with "C#" display can be set for each condition.
1. Use the [▲/+ ] or [▼/- ] key to move the cursor to "C#" and press the [Enter] key to enter the condition selection mode. Use the [▲/+ ] or [▼/- ] key to select the condition number "C#" and press the [Enter] key to decide the condition number.
  2. Next, adjust value of the condition selected by the [▲/+ ] or [▼/- ] key, and press the [Enter] key to enter the setting mode. Use the [▲/+ ] and [▼/- ] keys to change the setting value. When you are done, press the [Enter] key to exit the setting mode.

Go to 2/2 from any cursor position

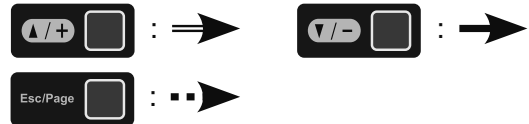

HeadHld A	C1	80%	Cond
HeadHld E	C1	80%	Cond

### (1) HeadHld A / HeadHld E: Head hold aileron / elevator

HeadHld A	C1	80%	HeadHld E	C1	80%
-----------	----	-----	-----------	----	-----

This features is used to adjust the heading hold aspect of the gyro control. If the helicopter is not holding angle or cyclic control rates, increasing the heading hold gain will improve holding the helicopter at a certain angle and improve the cyclic rate consistency. If this is set too high you could see an oscillation on that axis. Lowering the heading hold below default would be used if the transmitter gain is reduced and a consistent oscillation is still not fixed during flight.

Setting ranges: 0 ~ 200%    Initial value: 80%

StpTune A	C1	80%	Cond
-----------	----	-----	------

### (2) StopTune A : Stop tune aileron

StpTune A	C1	80%
-----------	----	-----

Cyclic stop tuning on the aileron axis. If the helicopter continues to coast after an after an ail roll, lowering "StpTune A" will create a harder stop action to remove the coasting. If the helicopter bounces on the aileron axis after an aileron control input, increasing "StpTune A" will reduce this bounce.

Setting ranges: 0 ~ 250%    Initial value: 80%

↑ ↓  
StpTune E [1] 80% Cond

**(3) StopTune E: Stop tune elevator** StpTune E [1] 80%

Cyclic stop tuning on the elevator axis. If the helicopter, after an elevator flip, continues to coast, lowering "StopTune E" will create a harder stop action to remove the coasting. If the helicopter continues to coast after an elevator flip, lowering the "Stop tune E" will reduce this bounce.

Setting ranges: 0 ~ 250% Initial value: 80%

↑ ↓

**FLT. EXPERT screen 2/2**

FLT.EXPERT	2/2
HeadResp	1
DeadBand	4.0
RESET	FLT.Tun

↑ ↓ ⋮ → Go to 1/2 from any cursor position

HeadResp [1]

**(4) HeadResp: Head Response** HeadResp [1]

Head Response matches the gyro control speed to that which the helicopter is capable of reacting. In a standard helicopter a Head Response of 1 should always be used, but on some scale applications, or uniquely designed rotor heads, increasing head response might be needed to cure over correction of the gyro.

Setting ranges: 1 ~ 10 Initial value: 1

↑ ↓

DeadBand [4.0]

**(5) DeadBand: Dead band** DeadBand [4.0]

Transmitter control dead band. If you are noticing inconsistent swash plate drift or poor initialization it could be poor transmitter potentiometer resolution. If you have to increase this value beyond 10.0, it is best to check calibration on your transmitter.

Setting ranges: 0 ~ 25 Initial value: 4.0

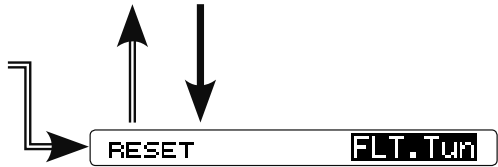

**(6) RESET : FLT tune data reset**

RESET

FLT.Tun

This resets the "FLT.Tun" setting back to the defaults. Move the cursor to "RESET" by pressing the [▲/+ ] or [▼/- ] key, and press the [Enter] key to enter the reset mode. With "EXECUTE: Enter (1sec)" displayed, press and hold the [Enter] key for about 1 second to initialize "FLT.Tun" setting. If you do not wish to reset, press [Enter] key or [Esc/Page] key to exit the reset mode.

Go to the menu title of FLT. EXPERT screen 1/2

# SWH. DETAIL MENU (SWASH DETAIL SETTING)

The swash detail setting is used to keep the swash plate level at high and low collective pitch to cyclic interactions and cyclic pitch to collective pitch interactions. Refer to page 72 and display the "SWH. DETAIL" screen from the "EXPERT MENU 3D" screen.

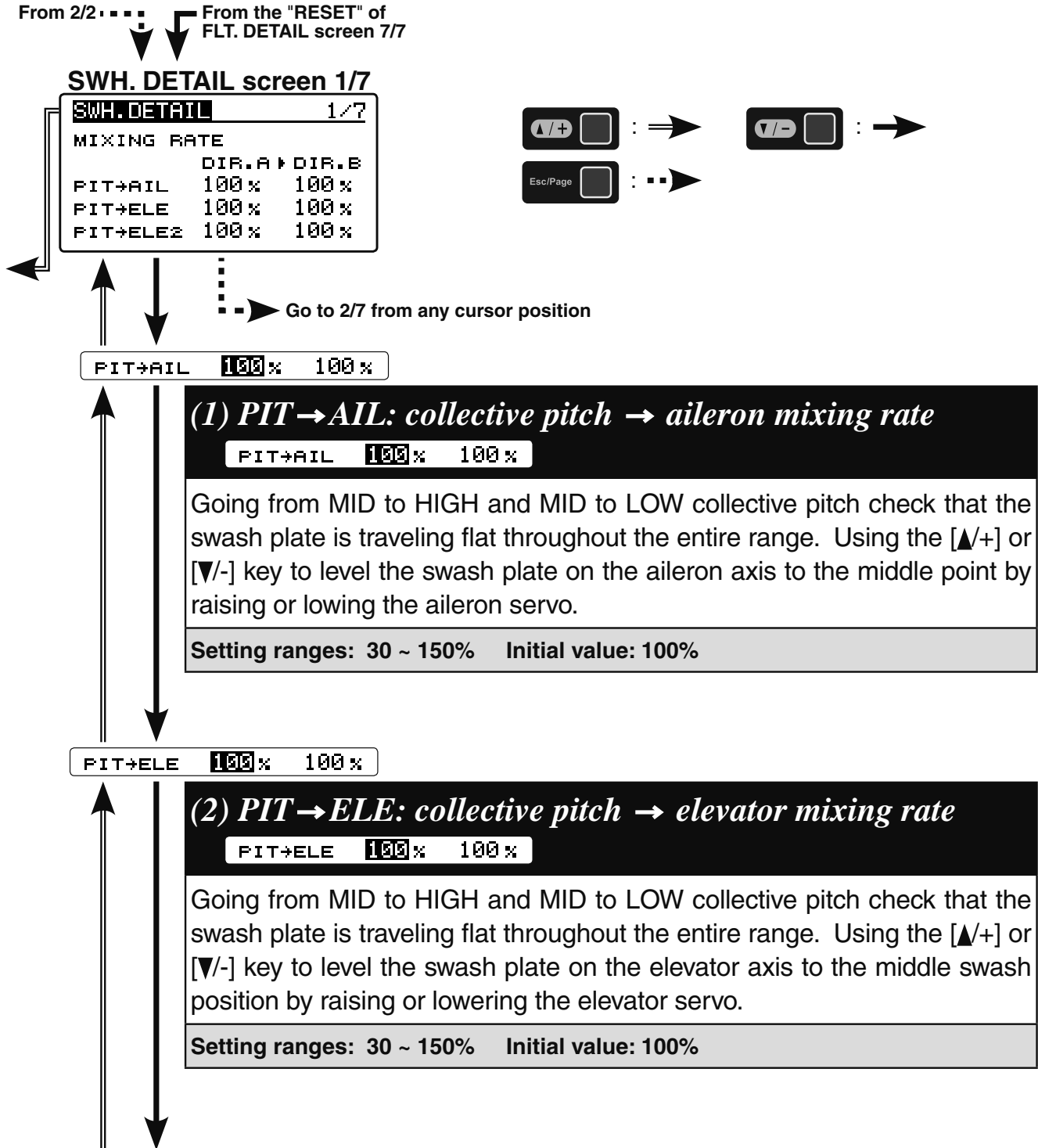



PIT→ELE2 100% 100%

### (3) PIT→ELE2: collective pitch → 2nd elevator mixing rate

PIT→ELE2 100% 100%

This parameter adjusts the pitch to 2nd elevator mixing rate. The rates can both be adjusted individually for both full high and low collective positions. **Note:** This setting is only available if the **H4-xx swash mode** has been selected.

Setting ranges: 30 ~ 150% Initial value: 100%

From 1/7

### SWH. DETAIL screen 2/7

```
SWH.DETAIL 2/7
MIXING RATE
DIR.A DIR.B
AIL→PIT 100% 100%
AIL→ELE 100% 100%
AIL→ELE2 100% 100%
```

AIL→PIT 100% 100%

Go to 3/7 from any cursor position

AIL→ELE 100% 100%

### (4) AIL→PIT: aileron → collective pitch mixing rate

AIL→PIT 100% 100%

At the middle collective pitch, check that during right to left and left to right aileron action the swash plate is staying level on both the elevator and collective pitch axis. If the swash plate is rising or falling with aileron inputs, use the [▲/+ ] or [▼/- ] key to raise or lower the swash plate to match the middle point during aileron inputs.

Setting ranges: 30 ~ 150% Initial value: 100%

### (5) AIL→ELE: aileron → elevator mixing rate

AIL→ELE 100% 100%

This parameter adjusts the aileron to elevator mixing rate. The rate can be adjusted for left and right directions individually. **Note:** This setting is only available if the **H4-45 swash mode** has been selected.

Setting ranges: 30 ~ 150% Initial value: 100%

AIL→ELE2 100% 100%

### (6) AIL→ELE2: aileron → 2nd elevator mixing rate

AIL→ELE 100% 100%

This parameter adjusts the aileron to 2nd elevator mixing rate. The rate can be adjusted for left and right directions individually. **Note:** This setting is only available if the **H4-45 swash mode** has been selected.

Setting ranges: 30 ~ 150% Initial value: 100%

From 2/7   
**SWH. DETAIL screen 3/7**

<b>SWH.DETAIL</b>		3/7
MIXING RATE		
	DIR.A	DIR.B
ELE→PIT	100%	100%
ELE→AIL	100%	100%
ELE→ELE2	100%	100%

Go to 4/7 from any cursor position  
 ELE→PIT **100%** 100%

**(7) ELE → PIT: elevator → collective pitch mixing rate**

AIL→PIT **100%** 100%

During back and forward elevator inputs at middle collective, check if the swash plate is raising or lowering during the input. If it is moving use the [▲ /+] or [▼/-] key to raise or lower the swash plate to match the middle point during elevator inputs. **Note:** This setting can not be used when **H4-00 swash mode** is selected.

Setting ranges: 30 ~ 150% Initial value: H3-120 = 50%, except H3-120 = 100%

ELE→AIL **100%** 100%

**(8) ELE → AIL: elevator → aileron mixing rate**

AIL→PIT **100%** 100%

While moving the elevator back and forth at middle collective, check to make sure the aileron axis is staying level. Use the [▲ /+] or [▼/-] key to raise or lower to level the swash plate so that it remains level during full forward and back elevator input. **Note:** This setting can not be used when **H4-00 swash mode** is selected.

Setting ranges: 30 ~ 150% Initial value: H3-120 = 50%, except H3-120 = 100%

ELE→ELE2 **100%** 100%

**(9) ELE → ELE2: elevator → 2nd elevator mixing rate**

ELE→ELE2 **100%** 100%

This parameter adjusts the elevator to 2nd elevator mixing rate. The rate can be adjusted separately for up and down directions individually. **Note:** This setting is only available if the **H4-xx swash mode** has been selected.

Setting ranges: 30 ~ 150% Initial value: 100%

From 3/7  
 SWH. DETAIL screen 4/7

```

  SWH.DETAIL 4/7
  COMPENSATION
  DIR.A DIR.B
  AIL High 0% 0%
  AIL Low 0% 0%
  AIL Dir +
  
```

Go to 5/7 from any cursor position

```

  AIL High 0% 0%
  
```

```

  AIL Low 0% 0%
  
```

### (10) AIL High / AIL Low: Linkage compensation aileron

```

  AIL High 0% 0% AIL Low 0% 0%
  
```

At HIGH pitch and LOW pitch check to make sure that the swash plate is staying level on the elevator and collective axis when using aileron inputs. If the swash plate is rising or falling, use the [▲/+] or [▼/-] key to maintain the swash plate position the same as that noted in the centered aileron inputs. **Note:** check all four directions: high/right; high/left; low/right; low/left

Setting ranges: 0 ~ 100% Initial value: 0%

```

  AIL Dir +
  
```

### (11) AIL Dir: Compensation direction of the aileron

```

  AIL Dir +
  
```

If the above Data (+/-) correction from 0-100 is NOT in the correct compensation direction, change the value from [+] or [-] using the [▲/+] or [▼/-] key.

Setting: +/- Initial setting: +

From 4/7  
 SWH. DETAIL screen 5/7

```

  SWH.DETAIL 5/7
  COMPENSATION
  DIR.A DIR.B
  ELE High 0% 0%
  ELE Low ▸ 0% 0%
  ELE Dir +
  
```

Go to 6/7 from any cursor position

```

  ELE High 0% 0%
  
```

```

  ELE Low ▸ 0% 0%
  
```

**(12) ELE High / ELE Low: Linkage compensation elevator**

```

  ELE High 0% 0%  ELE Low ▸ 0% 0%
  
```

At both the HIGH pitch and LOW pitch check to make sure that the swash plate is staying level on the aileron and collective axis when using elevator inputs. If the swash plate is rising or falling, use the [▲/+ ] or [▼/- ] key to maintain the swash plate position the same as it is in the middle during elevator inputs. **Note:** check all four directions: high/back; high/forward; low/back; low/forward.

Setting ranges: 0 ~ 100% Initial value: 0%

```

  ELE Dir +
  
```

**(13) ELE Dir: Compensation direction of the elevator**

```

  ELE Dir +
  
```

If the above Data (+/-) correction from 0-100 is NOT in the correct compensation direction, change the value from [+] or [-] using the [▲/+ ] or [▼/- ] key.

Setting: +/- Initial setting: +

From 5/7  
 SWH. DETAIL screen 6/7

```

  SWH.DETAIL 6/7
  Speed Comp  0%
  SWASH Rot   +0 DEG.
  
```

Go to 7/7 from any cursor position

```

  Speed Comp  0%
  
```

**(14) Speed Comp: Speed compensation**

```

  Speed Comp  0%
  
```

In 120 degrees CCPM all servos do not travel the same distance on elevator input. Having previously set the ELE-PIT and ELE-AIL parameters, if during rapid movement of the elevator axis the swash plate is not staying level, use the [▲/+] or [▼/-] key to match all servo speeds. **Note:** a (+ will slow the Aileron/Pitch Servo – will reduce speed comp on Aileron/Pitch Servo).

Setting ranges: 0 ~ 100% Initial value: H3-120 = 50%, except H3-120 = 0%

```

  SWASH Rot   +0 DEG.
  
```

**(15) SWASH Rot: Swash rotation**

```

  SWASH Rot   +0 DEG.
  
```

Using the [▲/+] or [▼/-] key, electronically add rotor head phasing to the swash plate controls. If possible, it is recommended to use mechanical phasing adjustment, but if the rotor head does not allow this and you feel that the model is NOT flying axially on each control input, this parameter can be used to adjust the pure reaction of each axis in flight. (Typically advanced phasing on clockwise rotor disk and a slight clockwise increase in swash plate alignment vs rotor axle are needed to create an axial reaction. The opposite is true for a counterclockwise rotor disk model.)

Setting ranges: -90 deg ~ +90 deg Initial value: +0 deg

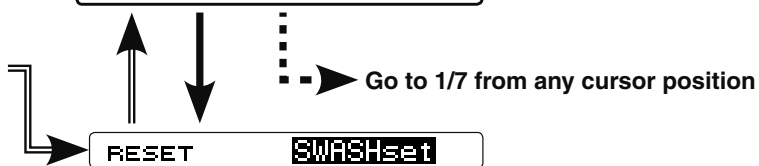
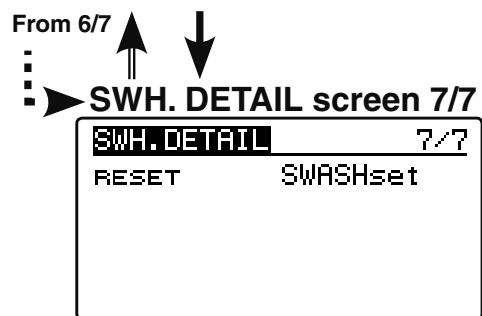

**(16) RESET : Swash detail data reset**    RESET    SWASHset

This resets the "SWH.DETAIL" setting back to the defaults. Move the cursor to "RESET" by pressing the [▲/+] or [▼/-] key. Press the [Enter] key to enter the reset mode. When "EXECUTE: Enter (1sec)" is displayed, press and hold the [Enter] key for about 1 second to initialize "SWH.DETAIL" setting. If you do not wish to reset, press either the [Enter] key or [Esc/ Page] key to exit reset mode.

Go to the menu title of SWH. DETAIL screen 1/7

# GOV. EXPERT MENU (GOVERNOR EXPERT SETTING)

This menu sets the Governor Expert parameters, allowing the user to further refine the governor settings. Refer to page 72 and display the "GOV EXPERT" screen from the "EXPERT MENU 3D" screen.

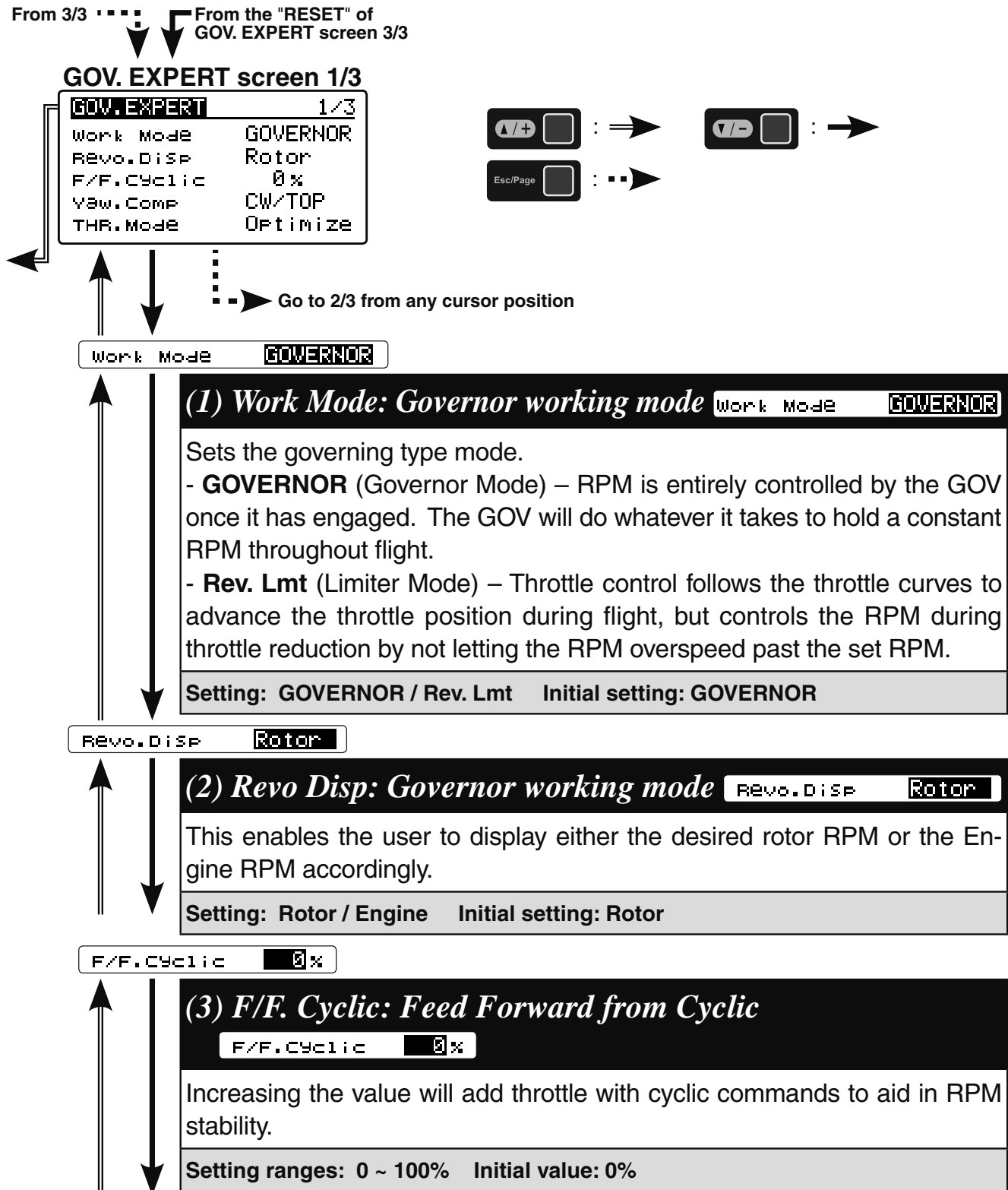

↑ ↓  
Yaw.Comp CW/TOP

**(4) Yaw. Comp: Governor working mode** Yaw.Comp CW/TOP

Yaw compensation allows the governor to more rapidly correct for changes in power demands of the model resulting from yaw input. Set the mode to match the gyro installation direction. Select from: CW/TOP, CW/BOTM, CCW/TOP, CCW/BOTM by pressing the [▲/+ ] or [▼/- ] key. **Note:** if the user has selected the governor only mode, this parameter is inhibited.

**Revolution fluctuation in the case of pirouettes**

The governor detects the rpm via the revolution sensor mounted in the engine section. During a pirouettes, the helicopter itself rotates, so that its pirouettes speed is added (reduced) to the engine speed. Therefore, the main rotor speed will fluctuate accordingly. Since the CGY 760R has a gyro, it can accurately measure the pirouette speed. The yaw rate correction is thus determined by a combination of gyro function and governor function.

**CW:** clockwise rotor direction

**CCW:** counter clockwise rotor direction

**TOP:** Gyro top/name emblem facing up

**BOTM:** Gyro top/name emblem facing down

Setting: CW/TOP, CW/BOTM, CCW/TOP, CCW/BOTM Initial setting: CW/TOP

↑ ↓  
THR.Mode Optimize

**(5) THR. Mode: Throttle data mode** THR.Mode Optimize

This parameter selects the throttle input operation. Pressing the [▲/+ ] or [▼/- ] key will change the mode.

**Optimize:**

CGY760R sets the throttle input signal to optimum. There is no need to consider the throttle curve setting on the transmitter.

**Fixed:**

This is the suggested mode for use with electric motors. This setting ensures that there is a fixed throttle input as is related to the helicopter revolution.

**Tx.Curve:**

If this mode is selected, the CGY760R uses the exact throttle input from the transmitter. As such, the throttle curve setting on the transmitter is required.

**Note:** when the Rev.Lmt mode is selected, this mode should also be selected.

Setting: GOVERNOR / Rev. Lmt Initial setting: GOVERNOR



From 1/3  
 GOV. EXPERT screen 2/3

GOV. EXPERT	2/3
Revo. Up Dly	8 Frm
Revo. Dn Dly	10 Frm
Start Dly	5 Frm
Gov. On. Revo	60 %
BFS. Volt	3.8 v

Revo. Up Dly 8 Frm

Go to 3/3 from any cursor position

Revo. Dn Dly 10 Frm

Start Dly 5 Frm

Gov. On. Revo 60 %

Gov. On. Revo 60 %

### (6) Revo. Up Dly: Revolution change up delay

Revo. Up Dly 8 Frm

How quickly the RPM changes when increasing RPM between two different RPM conditions and flight modes. A higher number slows the RPM change rate; a lower value speeds up the RPM change rate.

Setting ranges: 2 ~ 40 Frm Initial value: 8 Frm

### (7) Revo. Dn Dly: Revolution change down delay

Revo. Dn Dly 10 Frm

How quickly the RPM changes when reducing RPM between two different RPM conditions and flight modes. A higher number slows the RPM change rate; a lower value speeds up the RPM change rate.

Setting ranges: 2 ~ 40 Frm Initial value: 10 Frm

### (8) Start Dly: Start delay

Start Dly 5 Frm

How quickly the RPM stabilizes to the set RPM from when the GOV is turned ON. A higher value slows down the spool up rate; a lower value speeds up the spool up rate.

Setting ranges: 2 ~ 20 Frm Initial value: 5 Frm

### (9) Gov. On. Revo: Governor ON revolution setting

Gov. On. Revo 60 %

This parameter tells the governor at what percentage of the set rpm it is to become active. The default value is 60 %. In this case, the governor will not engage until the engine rpm reaches 60 % of the set rpm. If you feel that the time for governor engagement is too slow, decrease the value to 50 ~ 55%. The starting time will be faster.

Setting ranges: 50 ~ 90% Initial value: 60%

BFS.Volt 3.8 v

**(10) BFS. Volt: Battery F/S voltage setting** BFS.Volt 3.8 v

This parameter sets the battery fail safe and low battery alarm voltage levels, or thresholds. Set the proper voltage as determined by the battery type. The battery characteristics are different depending on cell type/chemistry. The voltage setting is changed by pushing the [▲/+ ] or [▼/- ] key. Suggested setting voltages are as follows.

- 4 cells NiCd or NiMH (Normal: 4.8v) = 3.8 v
- 2 cells LiFe (Normal: 6.6 v) = 6.0 ~ 6.2 v
- 2 cells LiPo (Normal: 7.4 v) = 7.2 ~ 7.4 v

From 2/3

GOV. EXPERT screen 3/3  
GOV. EXPERT 3/3  
Low.Revo 1000rpm  
RESET Governor

Go to 1/3 from any cursor position

Low.Revo 1000rpm

**(11) Low. Revo: Low revolution setting** Low.Revo 1000rpm

This value is set to assign the lowest possible governing RPM. If the RPM is below, or can not reach this RPM, the governor will not engage. Select between either 1,000 rpm or 700 rpm. It corresponds also to a helicopter with a rotor speed of 1,000 rpm or less, such as a large gas machine.

Setting: 700 / 1,000 rpm Initial setting: 1000 rpm

RESET Governor

**(12) RESET : Governor expert data reset** RESET Governor

This resets the "GOV. EXPERT" setting back to the defaults. Move the cursor to "RESET" by pressing the [▲/+ ] or [▼/- ] key. Press the [Enter] key to enter the reset mode. When "EXECUTE: Enter (1sec)" is displayed, press and hold the [Enter] key for about 1 second to initialize "GOV. EXPERT" setting. If you do not wish to reset, press [Enter] key or [Esc/Page] key to exit the reset mode.

Go to the menu title of GOV. EXPERT screen 1/3



# 3D VIA TRAINER Screen FUNCTION LIST

```
Via Trainer 1/9
<AIL/ELE>
CYC.Rt C1 300 d/s
Cnt.AuthAIL C1 40%
Cnt.AuthELE C1 40%
```

## **-FLT. TUNE**

CYC. Rt: Cyclic rate setting (page 52)  
 Cnt. AuthAIL: Control Authority Aileron (page 53)  
 Cnt. AuthELE: Control Authority Elevator (page 53)

```
Via Trainer 2/9
<AIL/ELE>
EXPO. C1 -20%
FLT.Styl C1 +50n
```

EXPO.: Exponential (page54)  
 FLT. Styl: Flight style (page54)

```
Via Trainer 3/9
<SWASH>
SWS.Rate C1 50%
PIT.Rate C1 50%
SWS.Ring C1 130%
```

## **-SWH. BASIC**

SWS. Rate: Rate adjustment (page 48)  
 PIT. Rate: Rate adjustment (page 49)  
 SWS. Ring (page 49)

```
Via Trainer 4/9
<GOVERNOR>
GOV.Gain C1 40%
L Lmt.L rpm C1 25%
L Lmt.H rpm C1 45%
```

## **- GOV. BASIC**

GOV Gain: Governor gain (page 65)  
 L Lmt. Hov : Low limit hovering RPM (page 65)  
 L Lmt. Idle : Low limit idling RPM (page 65)

```
Via Trainer 5/9
<FLT>
HeadHld A C1 80%
StpTune A C1 80%
HeadResp 1
```

## **-FLT. EXPERT**

HeadHld A : Head hold aileron (page 77)  
 StpTune A : Stop tune aileron (page 77)  
 HeadResp: Head Response (page 78)

```
Via Trainer 6/9
<FLT>
HeadHld E C1 80%
StpTune E C1 80%
```

HeadHld E: Head hold elevator (page 77)  
 StpTune E : Stop tune elevator (page 77)

```
Via Trainer 7/9
<RUD>
EXP.AVCS -20%
EXP.NORM -20%
```

## **-RUD. EXPERT**

EXP. AVCS: Rudder exponential AVCS (page 73)  
 EXP. NORM: Rudder exponential NORMAL (page 73)

```
Via Trainer 8/9
<RUD>
CNT.DlIn 15n
CNT.DlIn 15n
CNT.DlOut 12n
CNT.DlOut 12n
```

CNT. DIIn: Control delay in (page 74)  
 CNT. DIOut: Control delay out (page 74)

```
Via Trainer 9/9
<RUD>
ANG 720 d
Tail Resp. 1
```

ANG: Pirouette speed (page 75)  
 Tail Resp: Tail response (page 76)



# MOUNTING OF CGY760R WITH SCREWS

## ⚠ WARNING

❗ If using screws to mount the CGY760R to the helicopter, it is imperative to ensure that the machine does not vibrate excessively.

\*Please do not mount with machine screws with vibration, please mounting with a dedicated mounting pad.

### Drill holes in the plate

Refer to the figure below. Drill holes in the mounting plate accordingly.

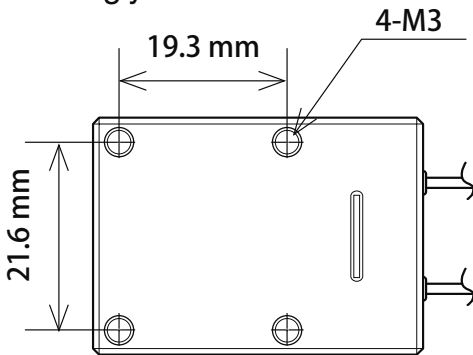

### Screw size for attachment

The effective length of the screw hole of the CGY760R main unit is 7mm.

Use the M3 screw whose length is less than the plate thickness plus 7mm.

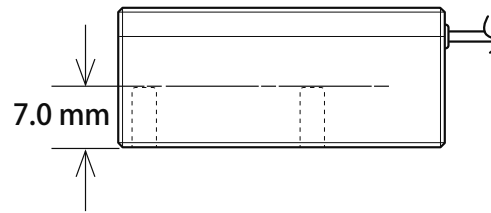

### Mounting

Attach the CGY760R to the mounting plate using M3 screws from the bottom of the plate as shown in the example.

Ensure that the screws are no longer than the plate thickness plus 7mm.

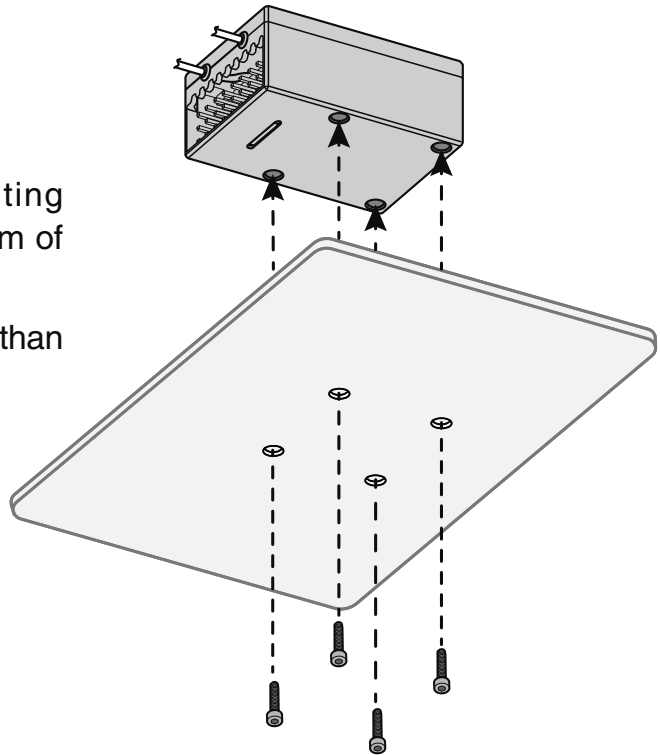

### Notes:

\*Ensure that these mounting screws will not come loose during flight.

\*As the CGY760R case is aluminum, please be careful not to over-tighten the mounting screws.

**CGY760R**

**Control System:** Digital advanced control  
**Angular Velocity Range:**  $\pm 1,000$  Degrees Per Second (Gyro)  
**Sensor:** Micro Electromechanical Systems (MEMS) Gyro  
Hall effect sensor  
**Governor Resolution:** 0.1Hz (6rpm) (Engine RPM)  
**RPM Accuracy:** 1%  
**Head Speed Range:** 700-4,000rpm  
**Selectable Servo Frame:** 70Hz, 280Hz and 560Hz (Rudder Gyro only) Rate  
**Center Pulse Width:** 1520 $\mu$ S (70Hz & 280Hz) 760 $\mu$ s (560Hz)  
**Receiving system:** FASSTest-2.4GHz (18CH/12CH mode )/T-FHSS-2.4GHz  
S.BUS2 / S.BUS Port and 6 Channels for Conventional System  
**Frequency band:** 2.4GHz band  
**RF power output:** 25m W EIRP  
**Antenna:** Dual antenna diversity  
**Rated voltage:** 3.7V to 7.4V DC\* (Operating Voltage:3.5V to 8.4V)  
**Current Drain:** 85mA (When receiving, no servo, no RPM sensor)  
**Operating Temperature:** 14°F to 113°F (-10°C to +45°C)  
**Size (CGY760R) :** 1.055in [26.8mm](W)/1.476in [37.5mm](L)/0.63in [16mm](H)  
**Size (Revolution sensor) :** 0.827in [21mm](W)/0.63in [16mm](L)/0.39in [10mm](H)  
**Weight (CGY760R) :** 0.713oz [20.2g]  
**Weight(RPM sensor):** 0.141oz [4g]

\*The operating voltage shown only applies to the CGY760R and GPB-1. Always verify that your receiver, servos, tail rotor servo, switch and any other electronic components used in your installation are capable of operating at the voltage you plan to use.

**GPB-1**

**Rated voltage:** 3.7V to 7.4V DC\* (Operating Voltage:3.5V to 8.4V)  
**Current Drain:** 62mA  
**Operating Temperature:** 14°F to 113°F (-10°C to +45°C)  
**Display:** 128 x 64 dot graphics  
**Size :** 2.126in [54mm](W)/3.543in [90mm](L)/0.6102in [15.5mm](H)  
**Weight(RPM sensor):** 1.88oz [53.3g]

---

FUTABA CORPORATION

oak kandakajicho 8F 3-4 Kandakajicho, Chiyoda-ku, Tokyo 101-0045, Japan

TEL: +81-3-4316-4820, FAX: +81-3-4316-4823

©FUTABA CORPORATION 2018, 06 (1)

*Flybarless Control Gyro*

**CGY760R**

Gyro Programmer Box

**GPB-1**